



ROEMHELD

Issue 3-07 E

K 1.010

matrix - Hydraulic Workpiece Clamping System clamping sets with swing clamps, single acting, max. operating pressure 200 bar

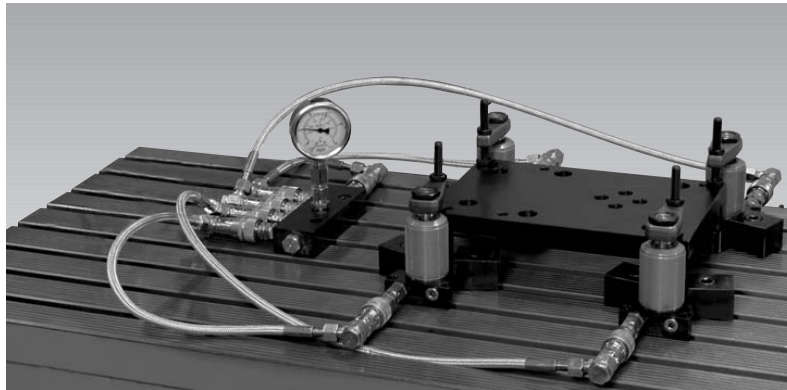

Application

matrix clamping sets with swing clamps are especially indicated for clamping of plates, shafts and other workpieces with simple contours directly on the machine tool table. Construction of a clamping fixture is not required. Preparations are limited to place and adapt the integrated supports and stops. For repeated parts use of a workpiece-specific base plate can be useful.

matrix allows the flexible adaptation of very different workpieces and offers all advantages of hydraulic workpiece clamping.

After positioning of the swing clamps the screwed-in support bolts can be milled vertically and horizontally.

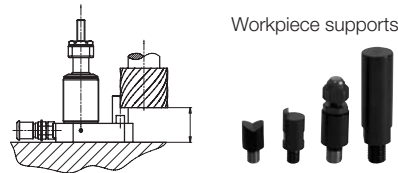

Thereby *matrix* allows an exact reference system directly on the machine.

Description

Clamping sets with 3 or 4 simple acting swing clamps with integrated workpiece support and all required parts to clamp workpieces hydraulically directly on the machine table.

matrix consists of:

- Swing clamps with integrated support
- Distributor bar with pressure gauge
- High-pressure hoses with coupling
- Fixing parts
- Hydraulic clamping pump (optional)
- Clamping and support unit (optional)

Function

1. Swing clamps

Swing clamps are pull-type cylinders where a part of the total stroke is used to swing the piston.

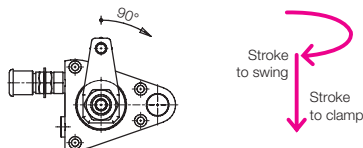

matrix swing clamps have been developed on the base of the proven series as per data sheet B 1.881.

2. Clamping and support unit

For workpieces with 4 support points, which are not exactly in one plane, *matrix* offers a clamping set with 3 swing clamps and one clamping and support unit with integrated work support and sequence valve. The bigger overall height is compensated at the three swing clamps by the supplied intermediate plates. At the distributor bar a further sequence valve is manifold mounted.

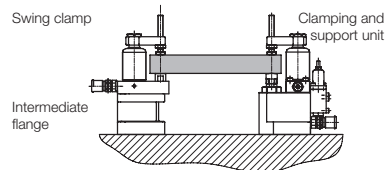

Sequence of the clamping cycle:

1. 3 swing clamps clamp the workpiece onto three fixed points
2. The work support contacts the fourth clamping point by spring force
3. The 4th swing clamp clamps the workpiece against the now fixed work support

This 4 point clamping with minimum deformation is the condition for production of workpieces true to dimensions. If required, further work supports can be used at critical points (see accessories page 2).

Advantages

- Direct clamping on the machine tool table
- No additional fixture costs
- Economic, especially with small batch sizes
- Clamping sets immediately ready for use
- Workpiece supports individually adaptable
- High precision of the workpieces by milling an exact reference system on the machine
- Workpiece supports for free loading and unloading
- Simple adaptation for parts families by displacement of the clamping elements
- 2 sizes available
- Clamping with minimum deformation by exact adjustment and uniform clamping forces
- 4 point clamping with minimum deformation by the optional clamping and support unit
- Quick and uniform clamping
- Quick unclamping
- Simple production of hydraulic fixtures
- Maintenance-free elements
- Saving compared with individual purchase

Application example

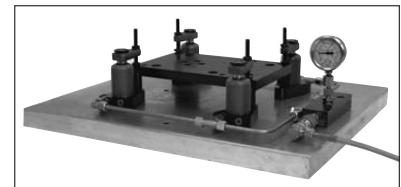

Hydraulic fixtures for repeated parts, which can be easily made by fixing the elements onto a base plate.

Important notes

Considerable injuries can be caused to fingers in the effective area of the clamping arm. Therefore pay attention especially during start-up of the system.

Operating conditions, tolerances and other data see data sheet A 0.100.

It is absolutely necessary to follow the instructions for venting of the spring area on data sheet A 0.110.





Subject to change without prior notice



ROEMHELD

Part numbers
Accessories

Part-nos. and parts included in the clamping sets

Clamping force at 200 bar Part-No.:	2.4 [kN]					5.8 [kN]				
	4415-100	4415-120	4415-130	4415-140	4415-150	4415-200	4415-220	4415-230	4415-240	4415-250
 Swing clamp 1883-894	3	3	4	4	3					
Swing clamp 1885-862						3	3	4	4	3
 Clamping and support unit 4412-985					1					
Clamping and support unit 4412-986										1
 Intermediate flange 3456-440					3					
Intermediate flange 3456-441										3
 Hydraulic clamping pump 8804-006	1			1		1			1	
Hydraulic oil, 1 litre 9895-001	1			1		1			1	
Hand lever 0990-103	1			1		1			1	
Locking flange 3533-466	1			1	1	1			1	1
Distributor bar 2360-219	1	1	1	1		1	1	1	1	
Distributor bar with sequence valve 2360-218					1					1
Hose 500 mm long 9375-616	2	2	2	2	2	2	2	2	2	2
Hose 750 mm long 9375-636	1	1	2	2	2	1	1	2	2	2
Hose 1000 mm long 9375-619	1	1	1	1	1	1	1	1	1	1
Hose 2500 mm long 9375-623	1	1	1	1	1	1	1	1	1	1
Clamping claw 3533-462	8	8	8	8	10	8	8	8	8	10
Support bolts D20 3443-675	3	3	4	4	3					
Support bolts D38 3443-676						3	3	4	4	3
Screw-in plug 3610-006	4	4	4	4	7	4	4	4	4	7
Tube male stud coupling 9208-003	8	8	8	8	10	8	8	8	8	10
Swivel banjo coupling 9208-004	3	3	3	3	4	3	3	3	3	4
Couplings and Dust caps 9384-106	3	3	4	3	4	3	3	4	3	4
Couplings and Dust caps 9384-300										
Coupling nipples and Dust caps 9384-206										
Coupling nipples and Dust caps 9384-400										

Components of clamping elements

Further accessories:

Support element for additional support points

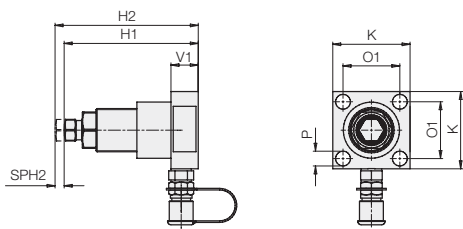

Description

Hydraulic work supports are used to provide a self-adjusting rest for the workpiece during the machining operations. They compensate the workpiece surface irregularities, also deflection and vibration under machining loads. The support plunger moves with spring force against the workpiece.

Off-position retracted:
The bolt contacts the workpiece by hydraulic pressure.

Off-position extended:
Bolt is retracted by the workpiece.

Adm. support force at 200 bar Part-No.:

	5.6 kN 4412-989	10 kN 4412-990
Off-position of the bolt	retracted	extended
Support stroke SPH2 [mm]	8	16
Operating pressure, min. [bar]	50	100
H1 [mm]	118	122
H2 [mm]	126	106
K [mm]	68	75
O1 [mm]	50	57
P [mm]	13	7
V1 [mm]	24	24

Further accessories:

Pressure switch	see data sheet F 9.731
Hydraulic high-pressure hoses	see data sheet F 9.360
Fittings, hydraulic oil, seamless precision steel tubes	see data sheet F 9.300
Pressure gauge,	
Hydraulic intensifier	see data sheet D 8.755
Distributor, quadruple	Part-no. 3534-395
Clamping arms for swing clamps	see data sheet B1.881 (page 4)



ROEMHELD

Technical characteristics
Dimensions

Swing clamp

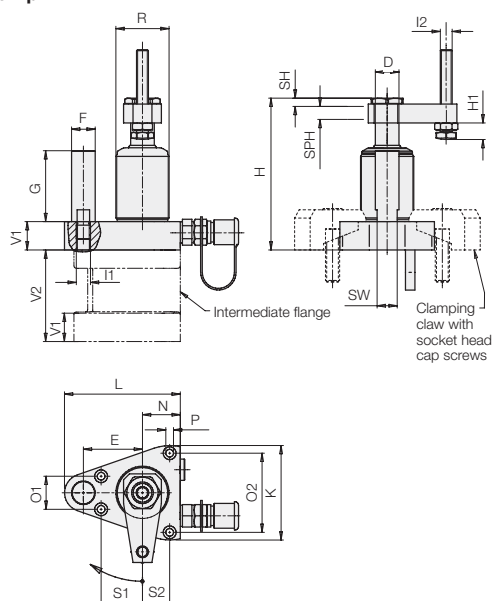

Effective clamping force F_{Sp} as a function of the clamping pressure p

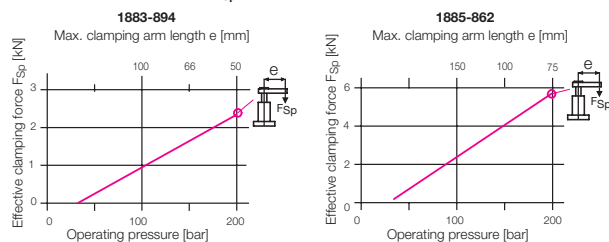

Clamping and support unit

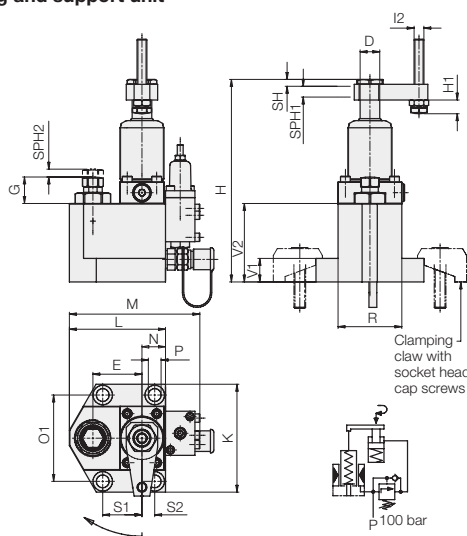

Swing clamp

Part-No.:	1883-894	1885-862
Swing stroke SH [mm]	7	8
Clamping stroke SPH [mm]	11	14
Total stroke STROKE [mm]	18	22
Min. operating pressure PMIN [bar]	30	30
Max. oil flow rate [cm ³ /s]	3,2	10
Oil for full stroke [cm ³]	3,2	10
D [mm]	20	32
E [mm]	50	75
F [mm]	20	38
G [mm]	60	62
H [mm]	128,5	149,5
H1 max. [mm]	64	79
H1 min. [mm]	6	9
I1 [mm]	M12	M20
I2 [mm]	M10	M16
K [mm]	80	104
L [mm]	98	134
N [mm]	32	38
O1 [mm]	28	40
O2 [mm]	67	80
P [mm]	6,5	8,5
R [mm]	45	60
S1 [mm]	35	50
S2 [mm]	23	12
V1 [mm]	24	24
V2 [mm]	77,5	109,5
SW [mm]	17	30
Declutch moment of overload protection [Nm]	3,5	11
Weight [kg]	2,22	4,67

Intermediate flange

Part-No.:	3456-440	3456-441
K [mm]	80	104
L [mm]	98	134
V1 [mm]	24	24
V2 [mm]	77,5	109,5
Weight [kg]	2,06	4,74

Clamping and support unit

Part-No.:	4412-985	4412-986
Swing stroke SH [mm]	7	8
Clamping stroke SPH1 [mm]	11	14
Total stroke STROKE [mm]	18	22
Support stroke SPH2 [mm]	8	16
Min. operating pressure PMIN [bar]	30	30
Max. oil flow rate [cm ³ /s]	3,2	10
Oil for full stroke [cm ³]	4,0	13,3
D [mm]	20	32
E [mm]	50	75
G [mm]	27	47
H [mm]	206,5	233,5
H1 max. [mm]	64	79
H1 min. [mm]	6	9
I2 [mm]	10	16
K [mm]	110	130
L [mm]	98	145
M [mm]	133	180
N [mm]	24	34
O1 [mm]	88	108
P [mm]	13	13
R [mm]	65	86
S1 [mm]	40	72
S2 [mm]	13	22
V1 [mm]	24	24
V2 [mm]	80	90
Declutch moment of overload protection [Nm]	3,5	11
Weight [kg]	6,60	13,98



ROEMHELD

Technical characteristics
Dimensions

Clamping claw

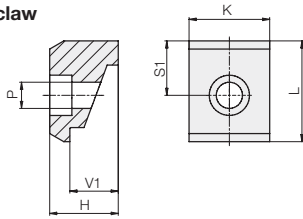

Clamping claw	Part-no.	3533-462
H	[mm]	34
K	[mm]	40
L	[mm]	50
P	[mm]	13
S1	[mm]	27
V1	[mm]	24

Hydraulic clamping pump

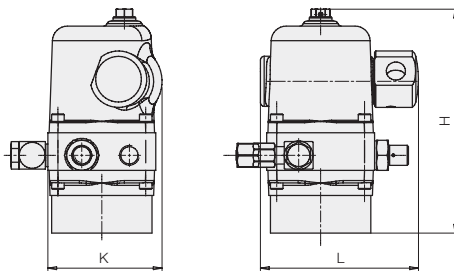

Hydraulic clamping pump	Part-no.	8804-006
Max. operating pressure	[bar]	200
Oil volume V	[cm ³]	300
Oil volume, usable	[cm ³]	150
Displacement per stroke	[cm ³]	4
Weight	[kg]	6,1
H	[mm]	178
K	[mm]	91
L	[mm]	126

The *matrix* clamping sets with hydraulic clamping pumps are supplied with hand lever 0990-103 as well as 1 litre hydraulic oil HLP 32.

Accessory

Suitable hand lever	Part-no.	0990-103
Suitable foot pedal	Part-no.	0990-102

Further variants, data and accessories see data sheets D 8.800 and D 8.817.

Locking flange

for hydraulic clamping pump

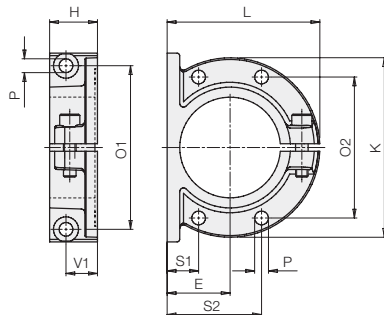

Locking flange	Part-no.	3533-466
E	[mm]	50
H	[mm]	38
K	[mm]	143
L	[mm]	121
O1	[mm]	130
O2	[mm]	112
P	[mm]	11
S1	[mm]	25
S2	[mm]	75
V1	[mm]	25

Further flanges and accessories see data sheet D 8.800.

Distributor bar

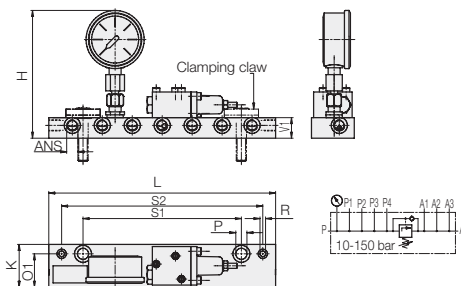

Part-No.:	Distributor bar without sequence valve	Distributor bar with sequence valve
	2360-219	2360-218
Min. sequence pressure	[bar]	30
Connecting thread	ANS	6 x G1/4
H	[mm]	approx. 150
K	[mm]	50
L	[mm]	150
O1	[mm]	39
P	[mm]	13
R	[mm]	6,5
S1	[mm]	80
S2	[mm]	120
V1	[mm]	24

Description

Sequence valves are used in power workholding for pressure-dependent sequence controls.

In *matrix* systems the functions extending and locking of the clamping and support elements is controlled by the sequence valve.