



ROEMHELD

Issue 7-03 E

D 8.755

Hydraulic Intensifier intensification ratio 1.5 to 7.5, max. operating pressure 500 bar

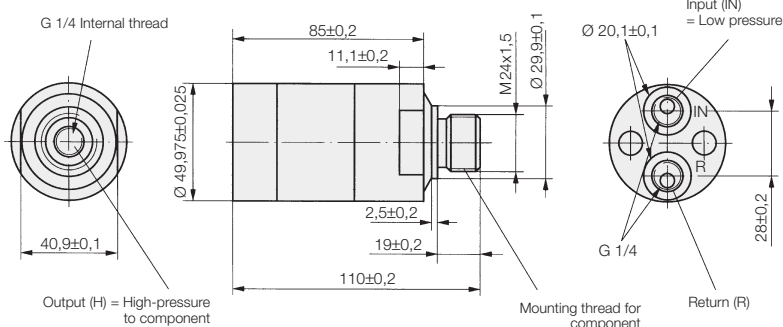

Application

The hydraulic intensifier converts a hydraulic pressure on the primary side (input) into a higher pressure on the secondary side (output).

This enables the use of the comparatively low pressure of machine tool hydraulics to pressurise a hydraulic cylinder with a correspondingly increased intensification ratio.

Description

The construction of the hydraulic intensifier corresponds to the principle of pressurising areas of different sizes. Regulation of the high pressure at the secondary side is made by regulation of the low pressure at the primary side and is directly proportional.

First the intensifier delivers a high flow rate at low pressure (displacement of the cylinders), with increasing counterpressure the intensifier switches automatically to pressure intensification. For unclamping the cylinder is directly controlled with the low-pressure of the primary side (see example).

Operating conditions, tolerances and other data see data sheet A 0.100.

Function

The oil is supplied through input **IN** via the check valves **RV1**, **RV2** and **DV** to the high-pressure output **H** and thereby to the cylinders. In this phase the intensifier is in rapid function. According to the intensification **i** the max. flow rate can be up to 10 l/min.

With increasing pressure in the cylinder the oscillating pump unit **OP** (pulsation) automatically functions. If the adjusted high-pressure is obtained, pulsation of the intensifier is stopped.

Pulsation continues in case of dynamic application. Max. frequency of pulsation is 30 Hz.

To retract the cylinder, the internal check valve **DV** is controlled via port **R** and thereby free return through the intensifier is guaranteed.

Important notes

The hydraulic oil must be perfectly filtered with particles not larger than nominally 10 µm. We offer therefore filter units (see data sheet F 9.500), which can be directly integrated into the tubing at the low-pressure side.

If the intensifier will be used on uncoupled systems (no connection to the pressure generator) a pilot-controlled check valve should be mounted at the high-pressure side (consider min. control pressure for opening!).

Pilot-operated check valve, see accessories page 2.

When designing an installation, pay attention that there can be leakage between the ports **IN** and **R** of the high-pressure intensifier.

Leakage rate approx. 50 cm³/min

When using the intensifier in uncoupled systems there will be a pressure increase in the unclamping line due to the leakage. – Please contact us!

Example: Hydraulic circuit diagram

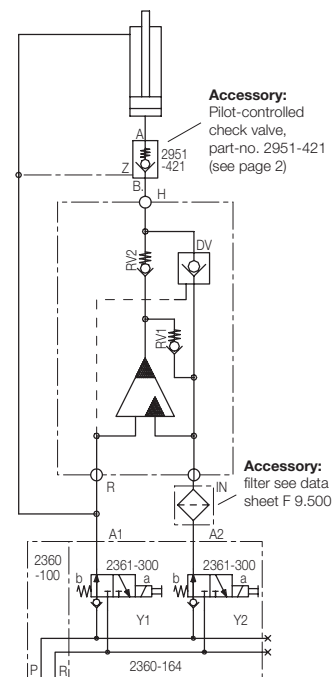

Intensification i	1.5	2.0	3.2	4.0	5.0
Max. flow rate, Low-pressure side Q_{IN} [l/min]	8	8	15	14	14
Max. flow rate, High-pressure side Q_{H} [l/min]	1	0.8	2.5	2.0	1.6
Max. operating pressure Low-pressure side P_{IN} [bar]	200	200	155	125	100
Max. operating pressure High-pressure side P_{H} [bar]	300	400	500	500	500
Weight [kg]	1.0	1.0	1.0	1.0	1.0
Part-no.	8755-015	8755-020	8755-032	8755-040	8755-050

Subject to change without notice



ROEMHELD

Hydraulic intensifier
small design –
intensification ratio 3.3 to 7.5

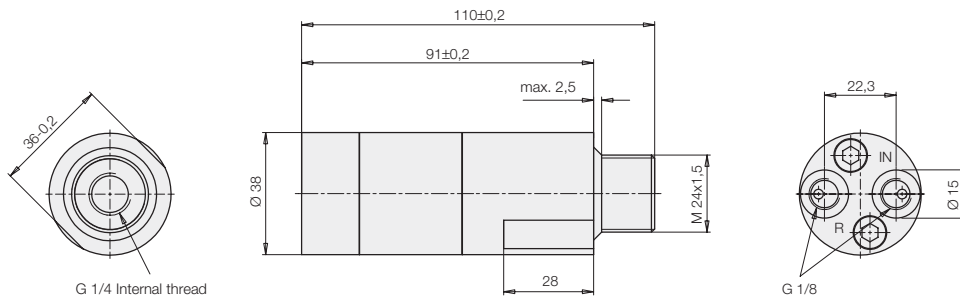

Intensification i	3.3	4.0	4.8	6.2	7.5
Max. flow rate, Low-pressure side Q_{IN}	8	8	8	8	8
Max. flow rate, High-pressure side Q_H	0.5	0.4	0.4	0.3	0.3
Max. operating pressure Low-pressure side P_{IN}	151	125	104	80	66
Max. operating pressure High-pressure side P_H	500	500	500	500	500
Weight	1.0	1.0	1.0	1.0	1.0
Part-no.	8755-132	8755-140	8755-148	8755-162	8755-175

Accessories

Pilot-operated check valve, pilot-controlled

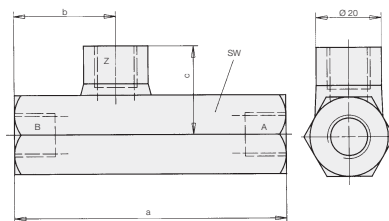
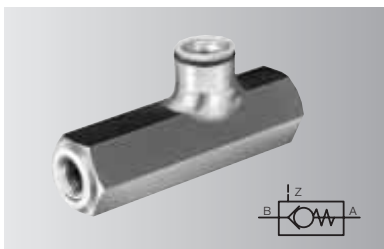

Configuration	spring-loaded ball-type poppet valve, leakage-free tubes
Type of mounting	Tube
Port size A,B	G1/2
Control port Z	G1/4
Control volume	[cm ³] 0.40
Control pressure $p_z \geq$	[bar] $0.12 p_A + 7$
Max. operating press.	[bar] 500
Flow max.	[l/min] 55
a	[mm] 100
b	[mm] 36.5
c	[mm] 31
SW	[mm] 32
Weight	[kg] 0.6
Part-no.	2951-421

Description

These check valves are designed in accordance with DIN ISO 1219. According to this definition this type of valve is a locking valve. The flow B → A is free. The flow from A → B is locked, but it can be hydraulically unlocked by pressurising control port Z.

Further pilot-operated check valves see page C 2.9511/2.

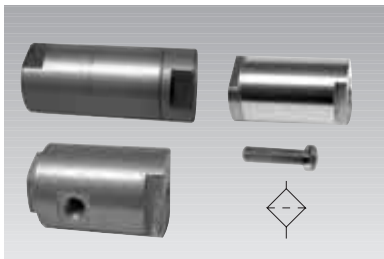

Hydraulic filter see data sheet F 9.500.