

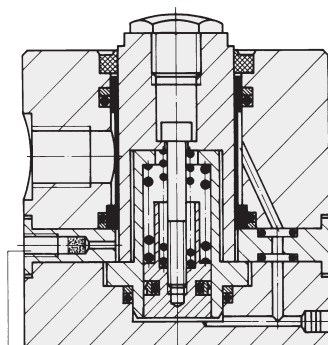

Work Supports

extending hydraulically - contact by spring force
single acting with spring return, max. operating pressure 500 bar

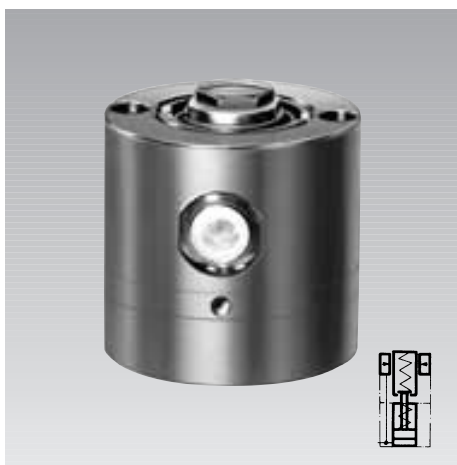

Sintered metal air filter and vent hose port ND 6.
Use connector **3610-035** for hose connection.

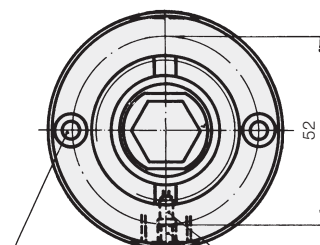
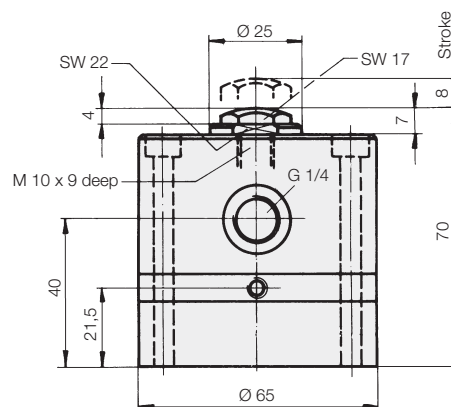

Counter bore 9,5 x 10 deep
for mounting screws
M 5 x 65 DIN 912

Description

The support plunger is retracted in off-position. When pressurised the support plunger moves against the inserted workpiece by means of light force. With increasing oil pressure, the plunger locks hydraulically. After the system has been unclamped, the support plunger returns to off-position. The support plunger is provided with female thread to enable the use of threaded pieces for height adjustment.

The internal part of the work support is protected against dust and swarf by a sintered metal air filter.

Important notes

If there is any danger of fluids being sucked into the filter, a vent hose has to be connected. The support plunger must always be protected against penetration of contamination by a contact bolt or a plug.

The plunger spring contact force with the workpiece is 15-30 N depending on the stroke. This force is functionally required for plunger movement and cannot be used to lift the workpiece nor to actuate linkages.

Operating conditions, tolerances and other data see data sheet A 0.100.

Teflon wiper
for high loads
available on request

Admissible load F as function of the operating pressure p

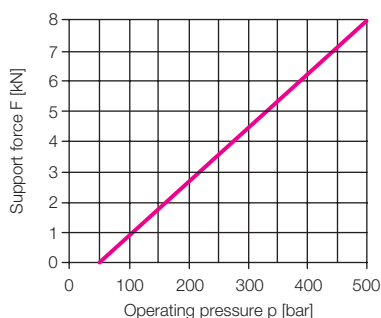

Plunger Ø	[mm]	25
Plunger stroke	[mm]	8
Oil for full stroke	[mm ³]	1.3
Max. oil flow rate	[cm ³ /s]	25
Recom. minimum oil pressure	[bar]	100
Weight	[kg]	4.1

Part-no. 1913-010

Accessories

Mounting screws M 5 x 65 DIN 912

Part-no. 3300-661