

## Built-in Piston single acting with spring return max. operating pressure 250 bar

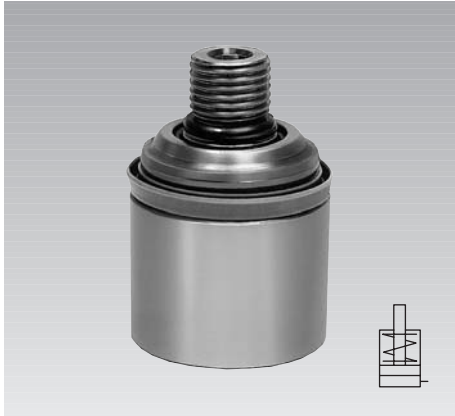

### Application

Easy installation in bars and blocks. Suitable for workpiece clamping and locking as well as for perforating, punching and stamping of sheet steel.

Very suitable for narrow and flat installation spaces. Compact multiple arrangement is possible. Mounting position: any. Hydraulic oil supply through drilled holes in the base. Only one oil port required.

### Description

Plunger piston with integrated pull-back spring, stroke limitation and fastening screw form a unit that cannot be disassembled. With PTFE-type piston seal. O-ring as static seal. Piston hardened and ground.

Wiper for case mounting supplied upon request.

Special seals on request.

### Advantages

- low built-in height
- very compact design
- extremely low overall height despite of return spring and fully utilisable stroke limitation
- easily exchangeable
- high force density

### Note:

Lateral forces less than 5% of clamping forces. To ensure perfect function, build-in dimensions and surface qualities are to be strictly observed. Use Allen key for assembly and disassembly. Replace O-ring after disassembly. Max. service temperature 80°C. Use Loctite no. 242 to secure thread.

### Important notes

Operating conditions, tolerances and other data see data sheet A 0.100.

Power units see catalogue section "D".

### Element

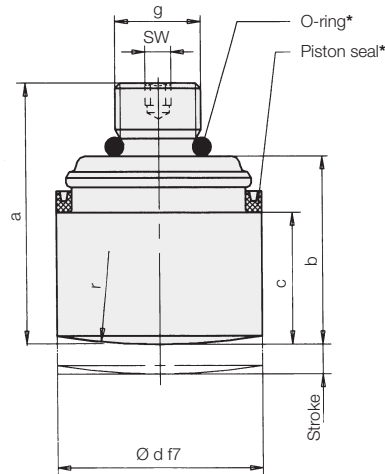

### Location hole

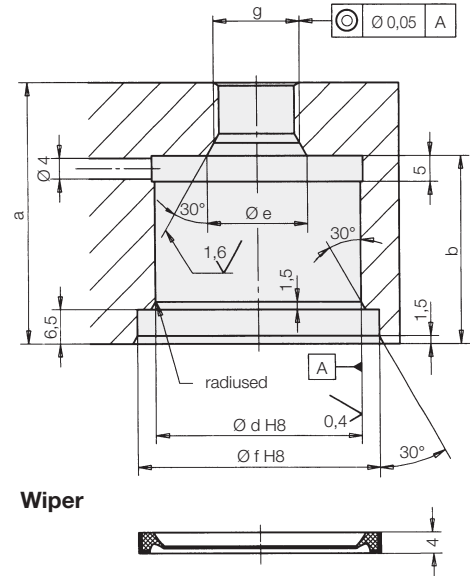

### Wiper

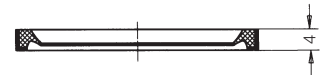

Clamping force at 250 bar	[kN]	12.25	20	31.25	48.75
Clamping force at 100 bar	[kN]	4.9	8	12.5	19.5
Spring return force. min.	[N]	130	200	230	400
Piston Ø d	[mm]	25	32	40	50
Stroke	[mm]	8	8	8	12
Total oil volume	[cm <sup>3</sup> ]	4	7	10	24
a	[mm]	40	47	50	75
b	[mm]	32.5	34.5	36	56
c	[mm]	23.5	25	26	43
e	[mm]	11.5	14	19.5	24
f	[mm]	32	42	47	58
g		G 1/8	G 1/4	G 3/8	G 1/2
r	[mm]	50	100	150	200
SW	[mm]	4	6	6	8
Seating torque	[Nm]	10	20	25	30
Weight	[kg]	0.10	0.17	0.28	0.59
<b>Part-no.</b>		<b>1072-010</b>	<b>1073-010</b>	<b>1074-010</b>	<b>1075-020</b>
<b>Wiper</b>	<b>Part-no.</b>	<b>3000-838</b>	<b>3000-710</b>	<b>3000-649</b>	<b>3000-484</b>
<b>Seal kit</b>	<b>Part-no.</b>	<b>5700-005</b>	<b>5700-006</b>	<b>5700-007</b>	<b>5700-008</b>
<b>Mounting sleeve</b>	<b>Part-no.</b>	<b>5700-009</b>	<b>5700-010</b>	<b>5700-011</b>	<b>5700-012</b>

\* O-Ring and piston seal are delivered with built-in piston

### Mounting sleeve and wiper

Use absolutely necessary!

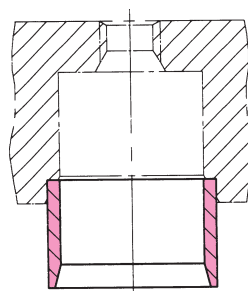

### Application example

Secured by means of Loctite no. 242

