



ROEMHELD

B 1.4301

Threaded-Body Cylinder

single acting, spring return, with wiper, short version
max. operating pressure 500 bar

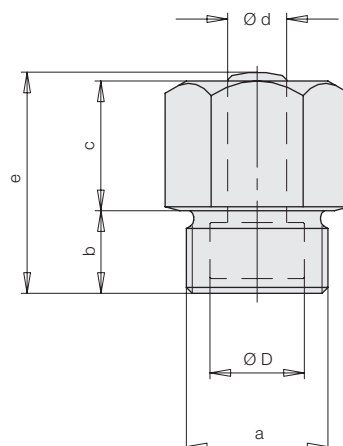
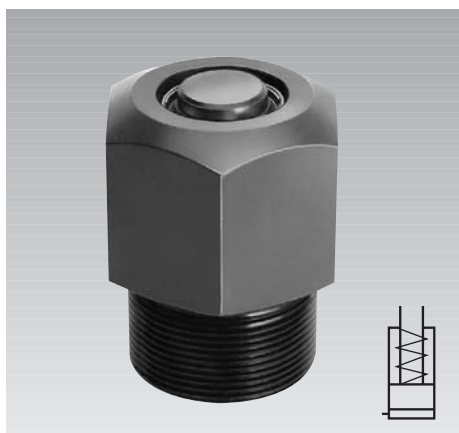

Porting details at fixture

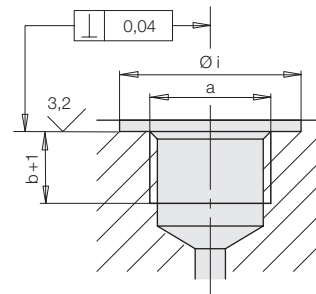

Sealing is attained by a knife edge at cylinder collar, requiring the sealing surface to be square to hole axis and flat.

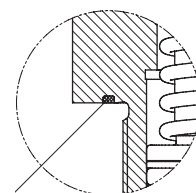

For piston $\varnothing D = 32$ mm the knife edge will be replaced by a Kantseal joint

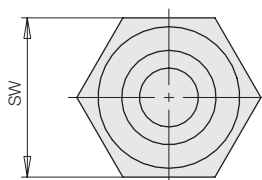

Description

These clamping cylinders may be threaded directly into tapped holes of the fixture.

These compact devices can be used to great advantage in fixtures where space is at a premium.

Hydraulic fluid is supplied through passages drilled into the fixture body, thus eliminating hydraulic hoses and threaded fittings.

The built-in spring returns the piston when hydraulic pressure is released.

Material

Piston material: casehardening steel, hardened
Cylinder body: free-cutting steel, black oxide

Important notes

Threaded-body cylinders must not be subjected to a load in retracted position.

Operating conditions, tolerances and other data see data sheet A 0.100.

Piston $\varnothing D$	[mm]	8	12	16	25	32
Rod $\varnothing d$	[mm]	5	8	10	16	20
Stroke ± 0.5	[mm]	4	4	6	12	16
Clamping force at 100 bar	[kN]	0.5	1.1	2.0	4.9	8
Clamping force at 500 bar	[kN]	2.5	5.6	10.0	24.5	40
Spring return force, min	[N]	25	32	56	151	183
Oil volume/10 mm stroke	[cm ³]	0.50	1.13	2.01	4.91	8.04
a	[mm]	M 16x1.5	M 20x1.5	M 24x1.5	M 36x1.5	M 42x1.5
b	[mm]	12	12	14	21	25
c	[mm]	14	14	21	33	40
e ± 0.5	[mm]	27	27	37	56	67
$\varnothing i$	[mm]	23	29	33	49	65
SW	[mm]	19	24	27	41	55
Max. seating torque	[Nm]	80	90	110	130	200
Weight	[kg]	0.065	0.10	0.17	0.40	0.90
Part-no.		1428-001	1430-101	1431-001	1433-001	1434-001

Application example

