

Fixed displacement radial piston pump

RE 11263/10.05
Replaces: 03.05

1/16

Type PR4

Sizes 1.60 to 20.00 cm³
Component series 3X
Maximum operating pressure 700 bar

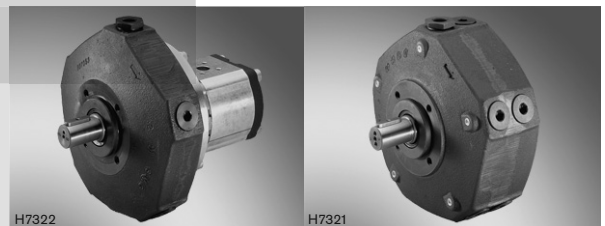

H7322 P2R4-3X/4,00-700RK01M01+AZPF8

H7321 PR4-3X/16,00-500RA01M01

Table of contents

Contents	Page
Ordering code for PR4	2
Function, section, symbol	3
Design variants for multi-circuit pumps	4
Technical data, noise pressure level	5
Flow and drive power	6
Characteristic curves	7
Unit dimensions	8 and 9
Seal kits	10
Multiple pumps	11 to 14
Ordering code for P2R4 and P3R4	11
Notes on the engineering of multiple pumps	12
Unit dimensions	13 and 14
Installation notes	15
Engineering notes	16
Commissioning note	16

Features

- Self-priming, valve-controlled
- 14 sizes, favourable gradations for optimum pump selection
- Long service life due to hydrodynamically lubricated sliding bearings
- Several pressure ports with various cylinder combinations

Ordering code

PR	4	3X	R				*
----	---	----	---	--	--	--	---

Type of device = PR

Series = 4

Component series

Component series 30 to 39 = 3X
(30 to 39: unchanged installation and connection dimensions)

Component size

Component size - pressure stage (maximum)

1.51 cm ³	(3)	= 1.60-700
2.14 cm ³	(3)	= 2.00-700
2.59 cm ³	(3)	= 2.50-700
3.57 cm ³	(5)	= 3.15-700
4.32 cm ³	(5)	= 4.00-700
7.14 cm ³	(10)	= 6.30-700 ¹⁾
8.63 cm ³	(10)	= 8.00-700 ²⁾
3.39 cm ³	(3)	= 3.15-500
4.82 cm ³	(3)	= 5.00-500
5.83 cm ³	(3)	= 6.30-500
8.03 cm ³	(5)	= 8.00-500
9.71 cm ³	(5)	= 10.00-500
16.07 cm ³	(10)	= 16.00-500 ¹⁾
19.43 cm ³	(10)	= 20.00-500 ²⁾

Direction of rotation

Clockwise rotation

= R

Further details in clear text

Number of pressure ports

Code	Number of pressure ports	Combination of cylinders		
		Radial piston pump with		
		3 pistons	5 pistons	10 pistons
01 =	1	3	5	10
02 =	2	1+2		5+5
03 =	3	1+1+1		
08 =	5		1+1+1+1+1	2+2+2+2+2
11 =	6			2+2+2+2+1+1
12 =	10			10x1

Seal material

M =

NBR seals

V =

FKM seals

Line connection

01 =

BSP thread to ISO 228/1

12 =

SAE thread to ANSI B1.1

Shaft version

A =

Cylindrical shaft end

G =

Serrated shaft 21x24 to DIN 5481

K =

Cylindrical shaft with output for mounting an AZPF or AZPFF

¹⁾ not available with shaft end (versions "G" and "K")

²⁾ not available with shaft end (version "K")

Function, section, symbol

Hydraulic pumps of type PR4 are valve-controlled, self-priming radial piston pumps with fixed displacement.

Radial piston pump type PR4 mainly consists of the housing (1), eccentric shaft (2) and 3, 5 or 10 pumping elements (3) with suction valve (4), pressure valve (5) and piston (6).

Suction and displacement process

The pistons (6) are arranged radially to the eccentric shaft (2). The hollow piston (6) with suction valve (4) is guided in a cylinder (7) and pressed by a spring (8) onto the eccentric shaft (2). The radius of the piston running face corresponds to the radius of the eccentric shaft. The cylinder (7) seals against a semi-spherical element (9).

As the piston (6) moves downwards, the working chamber (10) enlarges in cylinder (7). The ensuing negative pressure causes the suction valve plate to lift off the sealing edge. At the same time, the connection from suction chamber (12) to working chamber (10) is opened via a radial groove (11) in the eccentric shaft (2).

The working chamber fills with fluid. As the piston (6) moves upwards, suction valve (4) closes and pressure valve (5) opens. The fluid now flows via pressure port (P) into the system.

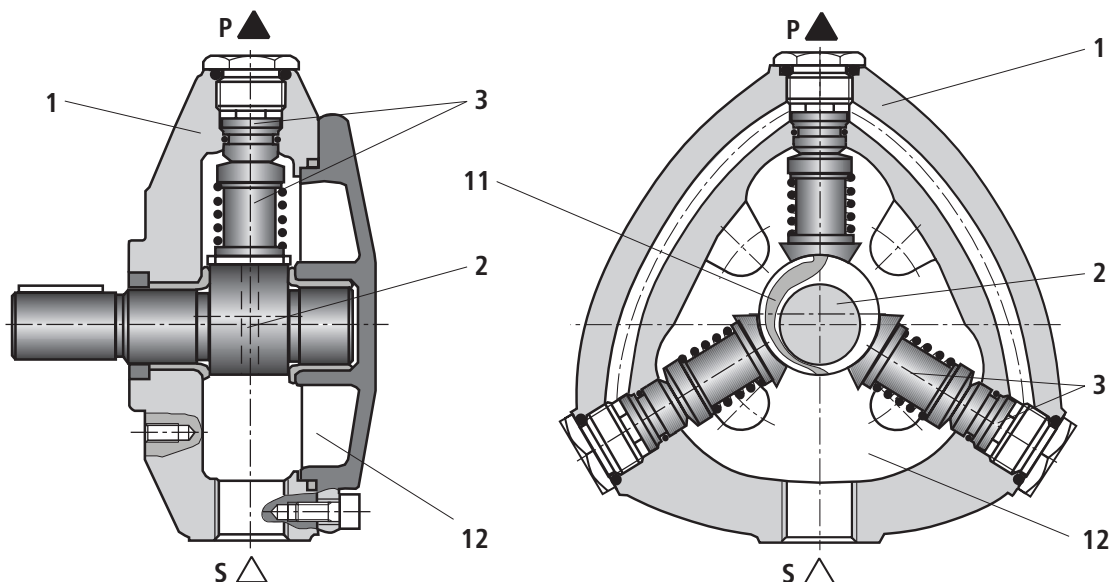
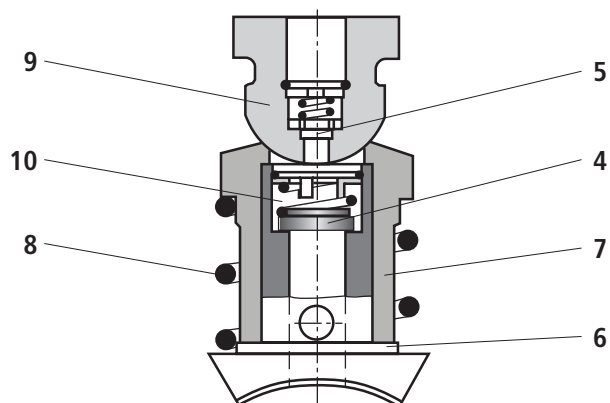
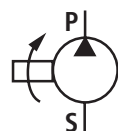

Design options for multi-circuit pumps

The following can be seen from the schematic diagrams below:

- The number and position of pressure ports,
- which cylinders are interconnected.

The dots indicate the cylinders that are connected directly to the pressurised pressure port.

The circles indicate the cylinders that are not connected directly to the pressurised pressure port.

The dotted and chain-dotted lines show, which cylinders are interconnected.

The pressurised pressure ports are numbered clockwise.

The pressure port, which - in the clockwise direction - is closest to the suction port, is identified with "P1".

Code	Number of pressure ports	Combination of cylinders		
		3 pistons	5 pistons	10 pistons
01	1			
02	2			
03	3			
08	5			
11	6			
12	10			

Technical data (for applications outside these parameters, please consult us!)

Speed range	min ⁻¹	1000 to 2000		
Operating pressure	Inlet	bar	0.8 to 2.5 absolute	
	Outlet	Cylinder ID	mm	Ø 10
		bar	700	500
Max. permissible torque (drive shaft)	Nm	160		
Installation position		Optional		
Shaft loading		Radial and axial forces cannot be absorbed		
Type of mounting		Face mounting		
Line connections		Screw-in fittings		
Direction of rotation (viewed to shaft end)		Clockwise		
Hydraulic fluid		HLP mineral oil to DIN 51524 part 2 Please observe the regulations according to RE 07075!		
Hydraulic fluid temperature range	°C	-10 to +70		
Viscosity range	mm ² /s	10 to 200		
Max. permissible degree of contamination of the hydraulic fluid - cleanliness classes to ISO 4406 (c)		Class 20/18/15 ¹⁾		
Weight	kg	3 pistons	5 pistons	10 pistons
		9.2	12.4	16.4

¹⁾ The cleanliness classes specified for components must be adhered to in hydraulic systems. Effective filtration prevents malfunction and, at the same time, prolongs the service life of the components. For the selection of filters, see data sheet RE 51144.

Noise pressure level (average value): (measured at $n = 1450 \text{ min}^{-1}$, $\nu = 41 \text{ mm}^2/\text{s}$ and $\vartheta = 50 \text{ }^\circ\text{C}$)

The characteristic curves are not valid for multi-circuit variants.

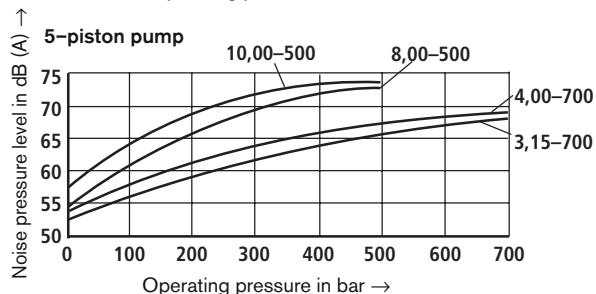
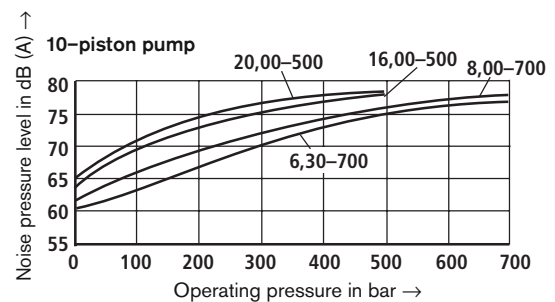
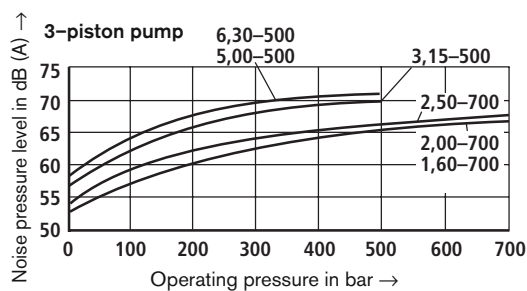

Measured in the anechoic chamber according to DIN 45635, part 26, distance from pump to microphone = 1 m

Flow and drive power (average value): referred to 1 cylinder ($n = 1450 \text{ min}^{-1}$)

Cylinder ID in mm	Stroke in mm	V_{geom} in cm^3		Operating pressure p in bar													
				50	100	150	200	250	300	350	400	450	500	550	600	650	700
10	6.4	0.509	$q_{V,\text{eff}}$ L/min	0.71	0.7	0.69	0.69	0.69	0.685	0.68	0.68	0.675	0.67	0.67	0.665	0.66	0.66
			P_a kW	0.093	0.164	0.231	0.29	0.358	0.42	0.481	0.54	0.605	0.67	0.739	0.81	0.888	0.97
10	9.1	0.714	$q_{V,\text{eff}}$ L/min	1.02	1.01	1.0	0.995	0.99	0.985	0.98	0.975	0.97	0.965	0.96	0.955	0.95	0.94
			P_a kW	0.129	0.23	0.328	0.41	0.503	0.58	0.677	0.77	0.856	0.94	1.046	1.16	1.257	1.36
10	11.0	0.864	$q_{V,\text{eff}}$ L/min	1.22	1.21	1.205	1.2	1.195	1.19	1.184	1.18	1.174	1.17	1.163	1.157	1.147	1.14
			P_a kW	0.15	0.275	0.392	0.49	0.594	0.7	0.804	0.91	1.018	1.13	1.244	1.37	1.486	1.61
15	6.4	1.13	$q_{V,\text{eff}}$ L/min	1.6	1.59	1.58	1.567	1.56	1.556	1.546	1.54	1.53	1.523				
			P_a kW	0.213	0.4	0.547	0.7	0.85	1.0	1.14	1.27	1.433	1.566				
15	9.1	1.61	$q_{V,\text{eff}}$ L/min	2.28	2.26	2.25	2.24	2.23	2.22	2.20	2.19	2.18	2.17				
			P_a kW	0.27	0.49	0.71	0.91	1.11	1.31	1.51	1.7	1.91	2.12				
15	11.0	1.94	$q_{V,\text{eff}}$ L/min	2.74	2.73	2.71	2.7	2.68	2.67	2.65	2.64	2.62	2.6				
			P_a kW	0.32	0.57	0.826	1.06	1.31	1.55	1.8	2.05	2.29	2.53				

Factor "f" for uneven running at $n = 1450 \text{ min}^{-1}$

The values given in the table "flow and drive power" refer to only 1 cylinder. In order to determine the required drive power, the value must be multiplied by the number of cylinders.

At the same time, the uneven running factor "f" must be applied.

Radial piston pump			
3 cylinders		5 or 10 cylinders	
Cylinders under load	Factor f	Cylinders under load	Factor f
1	3.13	1	3.13
1+2	1.57	1+2	1.89
		1+3	1.57
		1+2+3	1.60
		1+3+4	1.35
1+2+3	1.00	1+2+3+4	1.30
		1+2+3+4+5	1.00

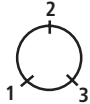

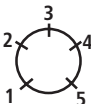

For pumps with 10 cylinders, 2 cylinders each are connected to a pressure port.

Example

Pump PR4-3X/1,60-700/RA01M02

Ports 1 and 2 are connected together and loaded to 450 bar, 3 is circulating at zero pressure.

$$P_a = 2 \times 0.605 \text{ kW} = 1.21 \text{ kW}$$

$$f = 1.57$$

$$P_{\text{erf}} = 1.21 \text{ kW} \times 1.57 = 1.90 \text{ kW}$$

Port 3 loaded to 300 bar,

1 and 2 circulating at zero pressure.

$$P_a = 0.42 \text{ kW}$$

$$f = 3.13$$

$$P_{\text{erf}} = 0.42 \text{ kW} \times 3.13 = 1.31 \text{ kW}$$

Ports 1, 2 and 3 loaded to 200 bar.

$$P_a = 3 \times 0.29 \text{ kW} = 0.87 \text{ kW}$$

$$P_{\text{erf}} = 0.87 \text{ kW} \times 1.0 = 0.87 \text{ kW}$$

Characteristic curves (measured at $n = 1450 \text{ min}^{-1}$, $v = 41 \text{ mm}^2/\text{s}$ and $\vartheta = 50 \text{ }^\circ\text{C}$)

Flow

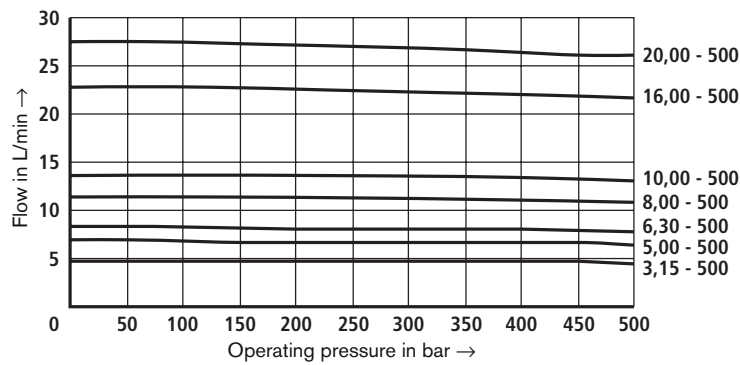
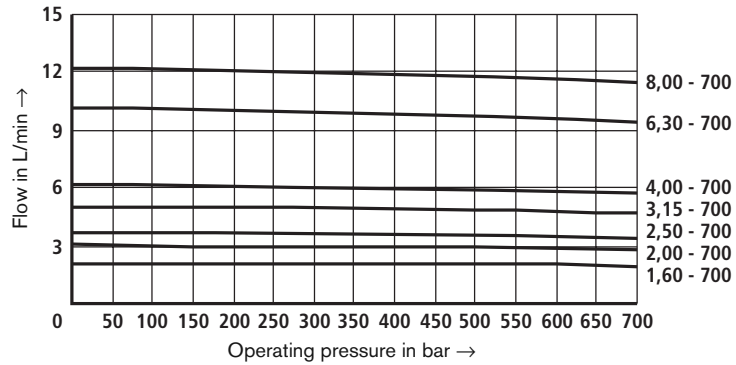

Drive power

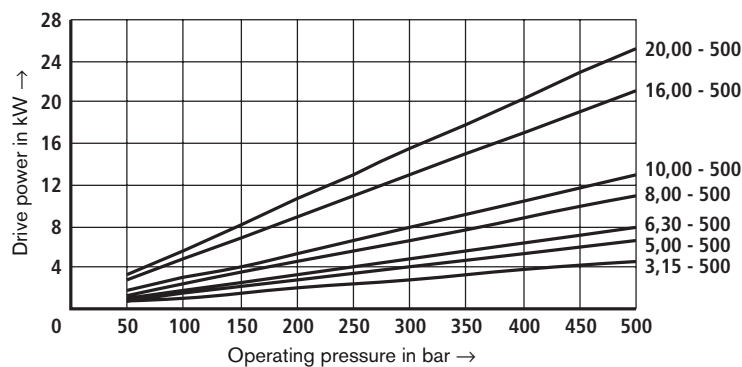
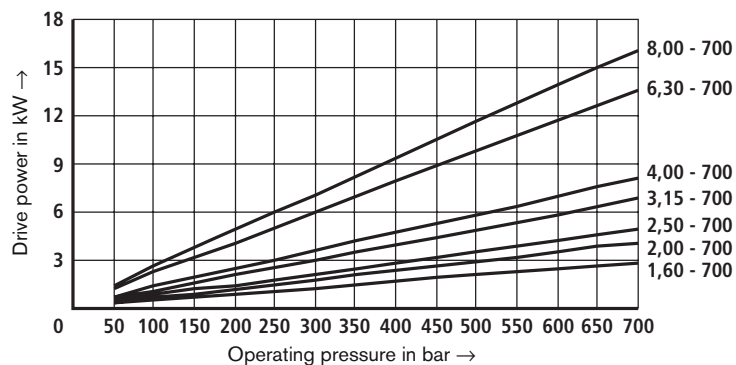

Unit dimensions: Radial piston pump with 3 pistons, nominal dimensions in mm (inch)

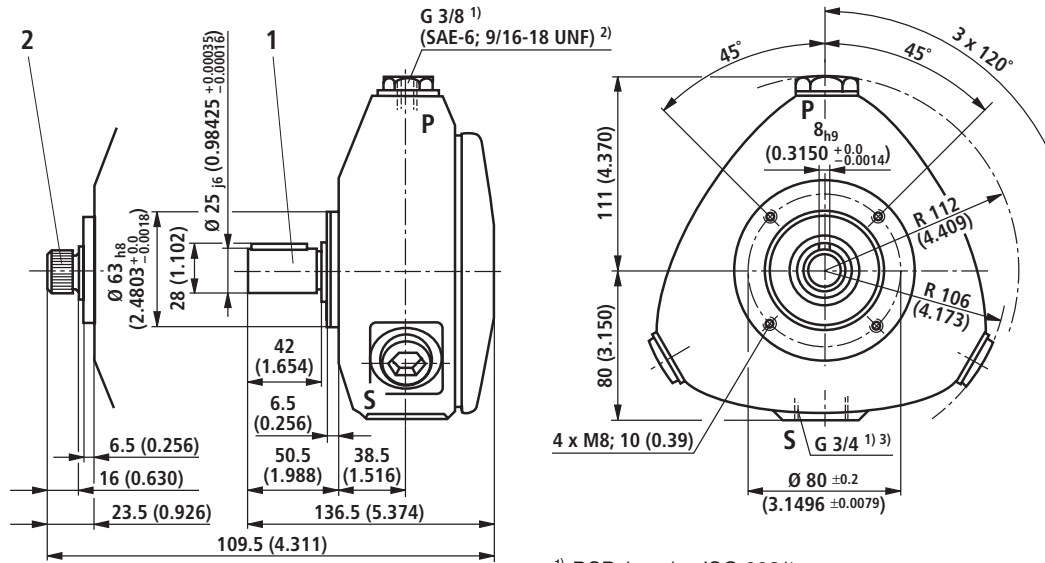

- 1 Cylindrical shaft end
- 2 Splined shaft to DIN 5481

- 1) BSP thread to ISO 228/1
- 2) For line connection with code 12 to ANSI B 1.1
- 3) For line connection with code 12, connection adapter (SAE-12; 1 1/16-12 UN) to ANSI B 1.1 not included in the scope of supply

Unit dimensions: Radial piston pump with 5 pistons, nominal dimensions in mm (inch)

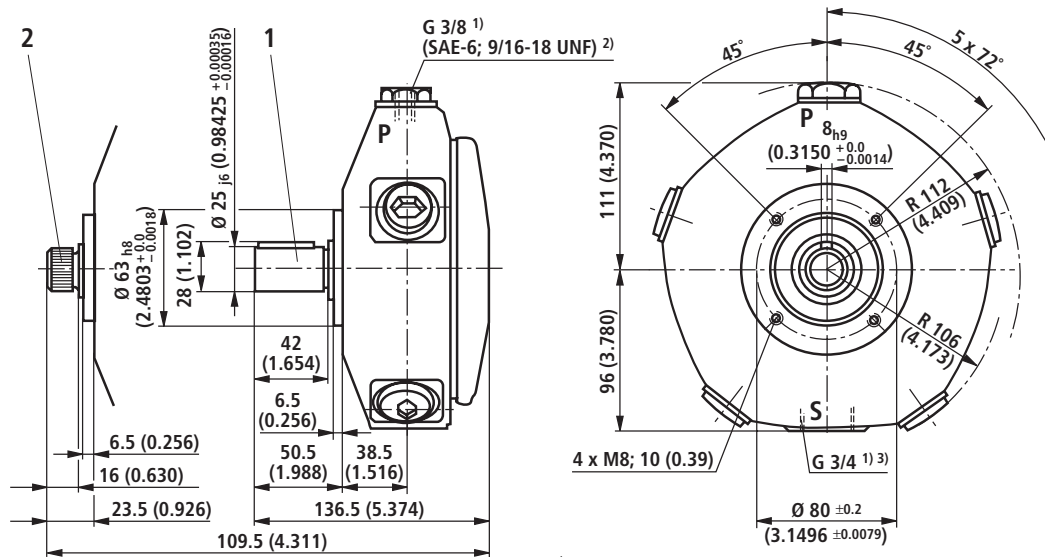

- 1 Cylindrical shaft end
- 2 Splined shaft to DIN 5481

- 1) BSP thread to ISO 228/1
- 2) For line connection with code 12 to ANSI B 1.1
- 3) For line connection with code 12, connection adapter (SAE-12; 1 1/16-12 UN) to ANSI B 1.1 not included in the scope of supply

Unit dimensions: Radial piston pump with 10 pistons, code 08, nominal dimensions in mm (inch)

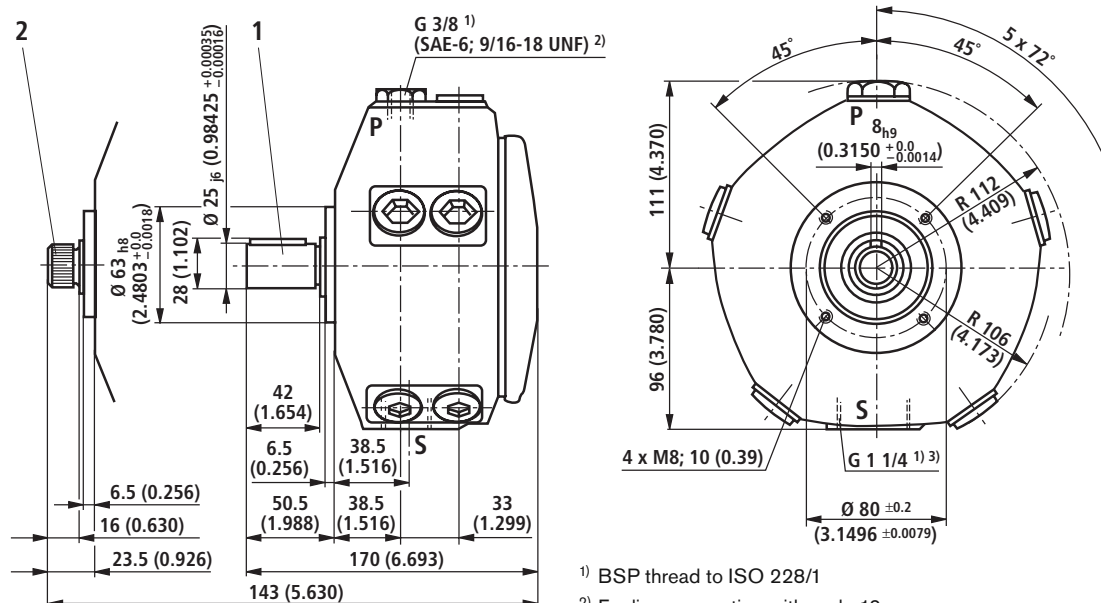

- 1 Cylindrical shaft end
- 2 Splined shaft end to DIN 5481

- 1) BSP thread to ISO 228/1
- 2) For line connection with code 12
- 3) For line connection with code 12, connection adapter (SAE-20; 1 5/8-20 UN) to ANSI B 1.1 not included in the scope of supply

Unit dimensions: Radial piston pump with 10 pistons, codes 11 and 12, nominal dimensions in mm (inch)

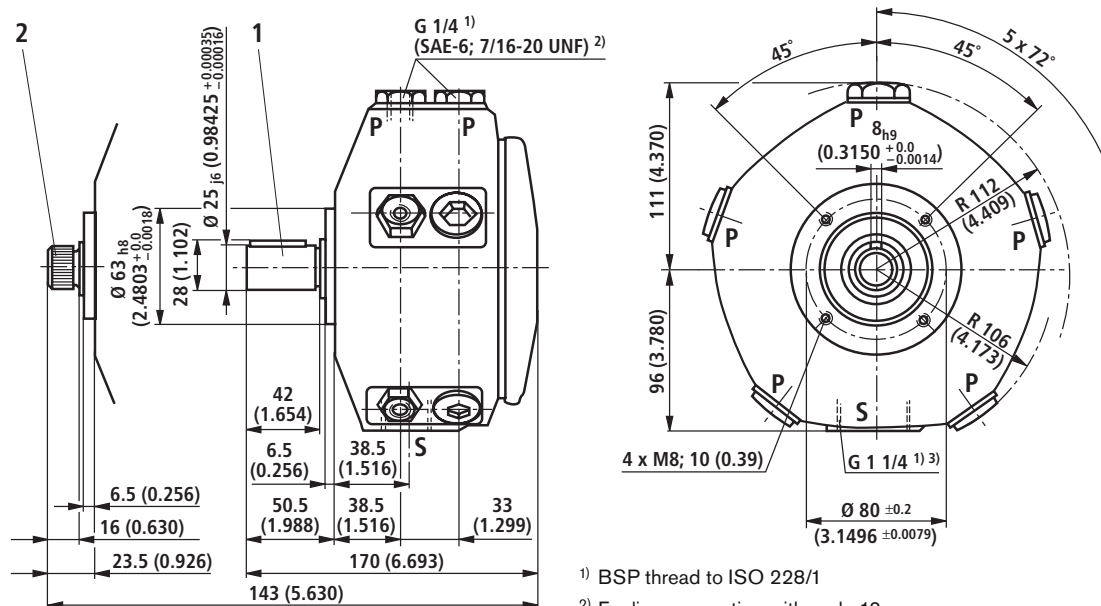

- 1 Cylindrical shaft end
- 2 Splined shaft end to DIN 5481

- 1) BSP thread to ISO 228/1
- 2) For line connection with code 12
- 3) For line connection with code 12, connection adapter (SAE-20; 1 5/8-20 UN) to ANSI B 1.1 not included in the scope of supply

Seal kits

Material number for NBR seals	Material number for FKM seals	Valid for
R900307726	R900307729	3-piston pumps
R900307727	R900307730	5-piston pumps
R900307728	R900307594	10-piston pumps

Ordering code for P2R4 and P3R4 pump combinations

	R4	3X	R	K	M	+	*																																																																																																						
<p>Type of device Double = P2 Triple = P3</p> <p>Series = 4</p> <p>Component series Component series 30 to 39 = 3X (30 to 39: unchanged installation and connection dimensions)</p> <p>Component size Component size - pressure stage (maximum)</p> <table border="0"> <tr><td>1.51 cm³</td><td>(3)</td><td>= 1.60-700</td></tr> <tr><td>2.14 cm³</td><td>(3)</td><td>= 2.00-700</td></tr> <tr><td>2.59 cm³</td><td>(3)</td><td>= 2.50-700</td></tr> <tr><td>3.57 cm³</td><td>(5)</td><td>= 3.15-700</td></tr> <tr><td>4.32 cm³</td><td>(5)</td><td>= 4.00-700</td></tr> <tr><td>3.39 cm³</td><td>(3)</td><td>= 3.15-500</td></tr> <tr><td>4.82 cm³</td><td>(3)</td><td>= 5.00-500</td></tr> <tr><td>5.83 cm³</td><td>(3)</td><td>= 6.30-500</td></tr> <tr><td>8.03 cm³</td><td>(5)</td><td>= 8.00-500</td></tr> <tr><td>9.71 cm³</td><td>(5)</td><td>= 10.00-500</td></tr> </table> <p>Direction of rotation Clockwise rotation = R</p> <p>Shaft version Cylindrical shaft end with output for mounting an AZPF or AZPFF = K</p> <p>Line connection BSP thread to ISO 228/1 = 01 SAE thread to ANSI B1.1 = 12</p> <p>Seal material NBR seals = M</p>	1.51 cm ³	(3)	= 1.60-700	2.14 cm ³	(3)	= 2.00-700	2.59 cm ³	(3)	= 2.50-700	3.57 cm ³	(5)	= 3.15-700	4.32 cm ³	(5)	= 4.00-700	3.39 cm ³	(3)	= 3.15-500	4.82 cm ³	(3)	= 5.00-500	5.83 cm ³	(3)	= 6.30-500	8.03 cm ³	(5)	= 8.00-500	9.71 cm ³	(5)	= 10.00-500	<p style="text-align: right;">Further details in clear text</p> <p>Component sizes for double pump</p> <table border="0"> <tr><td>AZPF4 =</td><td>4 cm³</td><td>($p_{max} = 280 \text{ bar}$)¹⁾</td></tr> <tr><td>AZPF5 =</td><td>5 cm³</td><td>($p_{max} = 280 \text{ bar}$)¹⁾</td></tr> <tr><td>AZPF8 =</td><td>8 cm³</td><td>($p_{max} = 280 \text{ bar}$)¹⁾</td></tr> <tr><td>AZPF11 =</td><td>11 cm³</td><td>($p_{max} = 230 \text{ bar}$)¹⁾</td></tr> <tr><td>AZPF14 =</td><td>14 cm³</td><td>($p_{max} = 180 \text{ bar}$)¹⁾</td></tr> <tr><td>AZPF16 =</td><td>16 cm³</td><td>($p_{max} = 160 \text{ bar}$)¹⁾</td></tr> <tr><td>AZPF19 =</td><td>19 cm³</td><td>($p_{max} = 135 \text{ bar}$)¹⁾</td></tr> <tr><td>AZPF22 =</td><td>22 cm³</td><td>($p_{max} = 110 \text{ bar}$)¹⁾</td></tr> <tr><td>AZPF25 =</td><td>25 cm³</td><td>($p_{max} = 100 \text{ bar}$)¹⁾</td></tr> <tr><td>AZPF28 =</td><td>28 cm³</td><td>($p_{max} = 90 \text{ bar}$)¹⁾</td></tr> </table> <p>Component sizes for triple pump</p> <table border="0"> <tr><td>AZPFF5-4 =</td><td>5 cm³ - 4 cm³</td></tr> <tr><td>AZPFF8-4 =</td><td>8 cm³ - 4 cm³</td></tr> <tr><td>AZPFF8-8 =</td><td>8 cm³ - 8 cm³</td></tr> <tr><td>AZPFF11-4 =</td><td>11 cm³ - 4 cm³</td></tr> <tr><td>AZPFF11-5 =</td><td>11 cm³ - 5 cm³</td></tr> <tr><td>AZPFF11-8 =</td><td>11 cm³ - 8 cm³</td></tr> <tr><td>AZPFF16-8 =</td><td>16 cm³ - 8 cm³</td></tr> <tr><td>AZPFF16-16 =</td><td>16 cm³ - 16 cm³</td></tr> </table> <p>Number of pressure ports</p> <table border="1"> <thead> <tr> <th rowspan="2">Code</th> <th rowspan="2">Number of pressure ports</th> <th colspan="2">Combination of cylinders</th> </tr> <tr> <th colspan="2">Radial piston pump with</th> </tr> <tr> <th></th> <th></th> <th>3 pistons</th> <th>5 pistons</th> </tr> </thead> <tbody> <tr> <td>01 =</td> <td>1</td> <td>3</td> <td>5</td> </tr> <tr> <td>02 =</td> <td>2</td> <td>1+2</td> <td></td> </tr> <tr> <td>03 =</td> <td>3</td> <td>1+1+1</td> <td></td> </tr> <tr> <td>08 =</td> <td>5</td> <td></td> <td>1+1+1+1+1</td> </tr> </tbody> </table>							AZPF4 =	4 cm ³	($p_{max} = 280 \text{ bar}$) ¹⁾	AZPF5 =	5 cm ³	($p_{max} = 280 \text{ bar}$) ¹⁾	AZPF8 =	8 cm ³	($p_{max} = 280 \text{ bar}$) ¹⁾	AZPF11 =	11 cm ³	($p_{max} = 230 \text{ bar}$) ¹⁾	AZPF14 =	14 cm ³	($p_{max} = 180 \text{ bar}$) ¹⁾	AZPF16 =	16 cm ³	($p_{max} = 160 \text{ bar}$) ¹⁾	AZPF19 =	19 cm ³	($p_{max} = 135 \text{ bar}$) ¹⁾	AZPF22 =	22 cm ³	($p_{max} = 110 \text{ bar}$) ¹⁾	AZPF25 =	25 cm ³	($p_{max} = 100 \text{ bar}$) ¹⁾	AZPF28 =	28 cm ³	($p_{max} = 90 \text{ bar}$) ¹⁾	AZPFF5-4 =	5 cm ³ - 4 cm ³	AZPFF8-4 =	8 cm ³ - 4 cm ³	AZPFF8-8 =	8 cm ³ - 8 cm ³	AZPFF11-4 =	11 cm ³ - 4 cm ³	AZPFF11-5 =	11 cm ³ - 5 cm ³	AZPFF11-8 =	11 cm ³ - 8 cm ³	AZPFF16-8 =	16 cm ³ - 8 cm ³	AZPFF16-16 =	16 cm ³ - 16 cm ³	Code	Number of pressure ports	Combination of cylinders		Radial piston pump with				3 pistons	5 pistons	01 =	1	3	5	02 =	2	1+2		03 =	3	1+1+1		08 =	5		1+1+1+1+1
1.51 cm ³	(3)	= 1.60-700																																																																																																											
2.14 cm ³	(3)	= 2.00-700																																																																																																											
2.59 cm ³	(3)	= 2.50-700																																																																																																											
3.57 cm ³	(5)	= 3.15-700																																																																																																											
4.32 cm ³	(5)	= 4.00-700																																																																																																											
3.39 cm ³	(3)	= 3.15-500																																																																																																											
4.82 cm ³	(3)	= 5.00-500																																																																																																											
5.83 cm ³	(3)	= 6.30-500																																																																																																											
8.03 cm ³	(5)	= 8.00-500																																																																																																											
9.71 cm ³	(5)	= 10.00-500																																																																																																											
AZPF4 =	4 cm ³	($p_{max} = 280 \text{ bar}$) ¹⁾																																																																																																											
AZPF5 =	5 cm ³	($p_{max} = 280 \text{ bar}$) ¹⁾																																																																																																											
AZPF8 =	8 cm ³	($p_{max} = 280 \text{ bar}$) ¹⁾																																																																																																											
AZPF11 =	11 cm ³	($p_{max} = 230 \text{ bar}$) ¹⁾																																																																																																											
AZPF14 =	14 cm ³	($p_{max} = 180 \text{ bar}$) ¹⁾																																																																																																											
AZPF16 =	16 cm ³	($p_{max} = 160 \text{ bar}$) ¹⁾																																																																																																											
AZPF19 =	19 cm ³	($p_{max} = 135 \text{ bar}$) ¹⁾																																																																																																											
AZPF22 =	22 cm ³	($p_{max} = 110 \text{ bar}$) ¹⁾																																																																																																											
AZPF25 =	25 cm ³	($p_{max} = 100 \text{ bar}$) ¹⁾																																																																																																											
AZPF28 =	28 cm ³	($p_{max} = 90 \text{ bar}$) ¹⁾																																																																																																											
AZPFF5-4 =	5 cm ³ - 4 cm ³																																																																																																												
AZPFF8-4 =	8 cm ³ - 4 cm ³																																																																																																												
AZPFF8-8 =	8 cm ³ - 8 cm ³																																																																																																												
AZPFF11-4 =	11 cm ³ - 4 cm ³																																																																																																												
AZPFF11-5 =	11 cm ³ - 5 cm ³																																																																																																												
AZPFF11-8 =	11 cm ³ - 8 cm ³																																																																																																												
AZPFF16-8 =	16 cm ³ - 8 cm ³																																																																																																												
AZPFF16-16 =	16 cm ³ - 16 cm ³																																																																																																												
Code	Number of pressure ports	Combination of cylinders																																																																																																											
		Radial piston pump with																																																																																																											
		3 pistons	5 pistons																																																																																																										
01 =	1	3	5																																																																																																										
02 =	2	1+2																																																																																																											
03 =	3	1+1+1																																																																																																											
08 =	5		1+1+1+1+1																																																																																																										

¹⁾ Observe the note on the engineering of multiple pumps (page 12)

Notes on the engineering of multiple pumps

- The general technical data of the single pumps are also valid for multiple pumps (see below and page 5).
- The pump that is subjected to greater loads (pressure x flow) should be the first pump stage.
- When several pumps are combined, the occurring torque can reach impermissibly high values.
- The sum of torques must not exceed the permissible values (see table below)

Pump type	Max. permissible	
	input torque T_{max}	output torque T_{max}
PR4...	160 Nm	45 Nm
AZPF...	45 Nm	45 Nm
AZPFF...	45 Nm	45 Nm

Single pump

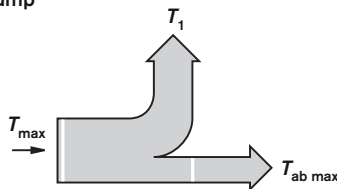

$$T = \frac{\Delta p \cdot V \cdot 0.0159}{\eta_{hydr.-mech.}} \text{ (Nm)}$$

Example: Pump combination
P3R4-3X/3,15-700... + AZPFF8-4

$$T_1 = \frac{700 \text{ bar} \cdot 3.57 \text{ cm}^3 \cdot 0.0159}{0.9} = 44.2 \text{ Nm}$$

$$T_2 = \frac{100 \text{ bar} \cdot 8 \text{ cm}^3 \cdot 0.0159}{0.85} = 15.0 \text{ Nm}$$

$$T_3 = \frac{50 \text{ bar} \cdot 4 \text{ cm}^3 \cdot 0.0159}{0.85} = 3.8 \text{ Nm}$$

$$T_{ab2} = 45 \text{ Nm}$$

$$T_3 = 3.8 \text{ Nm} \leq T_{ab2 \text{ max}}$$

$$T_{ab1} = 45 \text{ Nm}$$

$$T_{1,2} = T_2 + T_3$$

$$T_{1,2} = 18.8 \text{ Nm} \leq T_{ab1 \text{ max}}$$

$$T_{max} = 160 \text{ Nm}$$

$$T = T_1 + T_2 + T_3$$

$$T = 63 \text{ Nm} \leq T_{max}$$

Combination pump

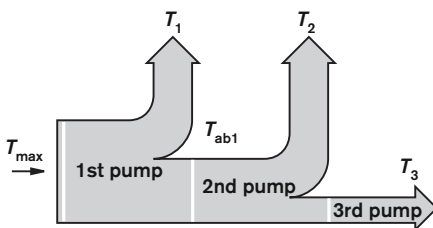
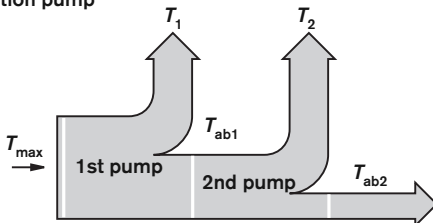

Calculation example:

- V = displacement in cm^3
- $\eta_{hydr.-mech.}$ = hydraulic-mechanical efficiency
- T = torque in Nm
- Δp = pressure in bar

The pump combination can be operated at the calculated technical data.

Unit dimensions: P2R4..., nominal dimensions in mm (inch)

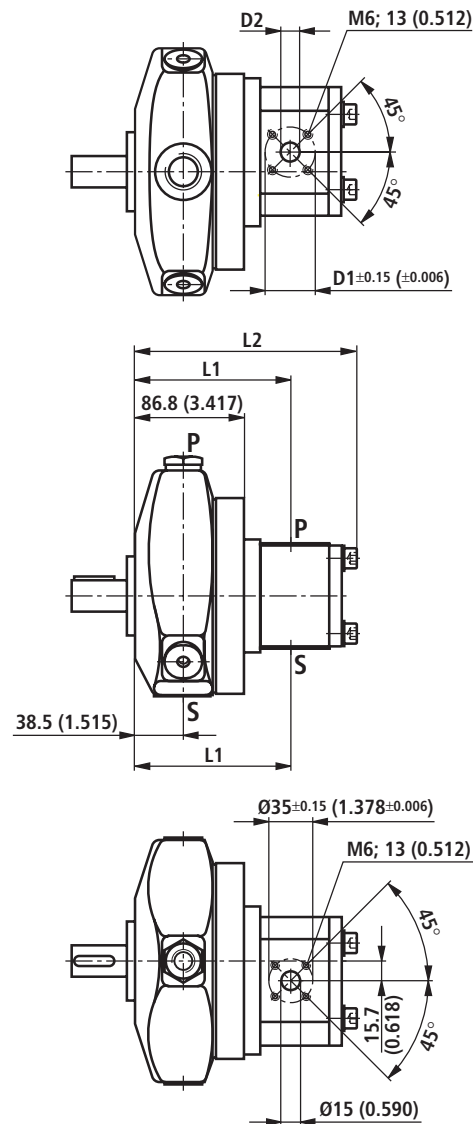

Type P2R4- ...+	D1 ±0.15 (±0.006)		D2		L1		L2	
	mm	(inch)	mm	(inch)	mm	(inch)	mm	(inch)
AZPF4	40.00	(1.575)	15.00	(0.591)	124.2	(4.890)	170.5	(6.713)
AZPF5	40.00	(1.575)	15.00	(0.591)	125.4	(4.937)	173.0	(6.811)
AZPF8	40.00	(1.575)	20.00	(0.787)	127.5	(5.020)	177.1	(6.972)
AZPF11	40.00	(1.575)	20.00	(0.787)	131.3	(5.169)	182.1	(7.169)
AZPF14	40.00	(1.575)	20.00	(0.787)	131.8	(5.189)	187.1	(7.366)
AZPF16	40.00	(1.575)	20.00	(0.787)	131.8	(5.189)	190.5	(7.500)
AZPF19	40.00	(1.575)	20.00	(0.787)	131.8	(5.189)	195.5	(7.697)
AZPF22	40.00	(1.575)	20.00	(0.787)	139.4	(5.488)	200.9	(7.909)
AZPF25	55.00	(2.165)	26.00	(1.024)	147.5	(5.807)	217.3	(8.555)
AZPF28	55.00	(2.165)	26.00	(1.024)	148.1	(5.831)	222.1	(8.744)

For dimensions missing for R4, see pages 8 and 9.

Unit dimensions: P3R4..., nominal dimensions in mm (inch)

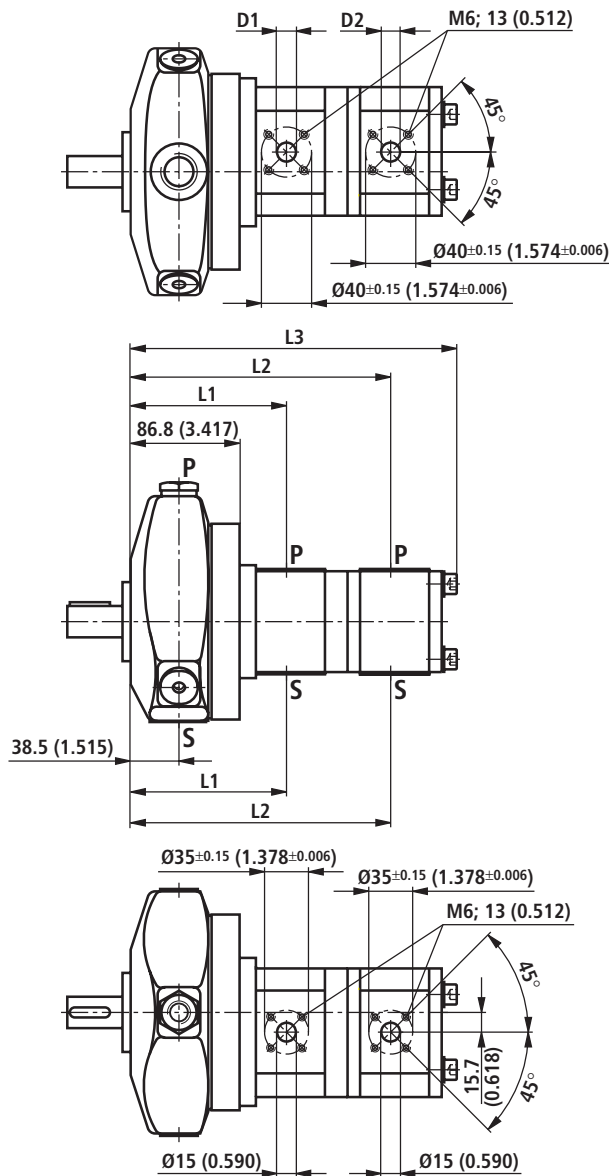

Type P3R4- ...+	D1		D2		L1		L2		L3	
	mm	(inch)	mm	(inch)	mm	(inch)	mm	(inch)	mm	(inch)
AZPFF5-4	15.00	(0.591)	15.00	(0.591)	125.4	(4.937)	208.4	(8.205)	254.7	(10.028)
AZPFF8-4	20.00	(0.787)	15.00	(0.591)	127.5	(5.02)	212.5	(8.366)	258.8	(10.189)
AZPFF8-8	20.00	(0.787)	20.00	(0.787)	127.5	(5.020)	215.8	(8.496)	265.4	(10.449)
AZPFF11-4	20.00	(0.787)	15.00	(0.591)	131.3	(5.169)	217.5	(8.563)	263.8	(10.386)
AZPFF11-5	20.00	(0.787)	15.00	(0.591)	131.3	(5.169)	218.7	(8.610)	266.3	(10.484)
AZPFF11-8	20.00	(0.787)	20.00	(0.787)	131.3	(5.169)	220.8	(8.693)	270.4	(10.646)
AZPFF16-16	20.00	(0.787)	20.00	(0.787)	131.8	(5.189)	233.5	(9.193)	292.2	(11.504)

For dimensions missing for R4, see pages 8 and 9.

Installation notes

Drive

El. motor + pump mounting bracket + coupling + pump

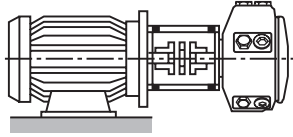

- No radial and axial forces permitted on the pump drive shaft!
- Motor and pump must be exactly aligned!
- Always use a coupling that is suitable for compensating for shaft offsets!
- When installing the coupling, avoid axial forces, that is, **do not hammer or press the coupling onto the shaft!** Use the female thread of the drive shaft!

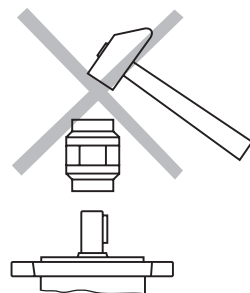

Installation positions

B3

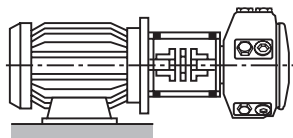

B5

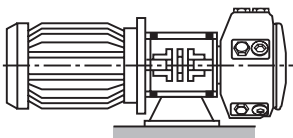

V1

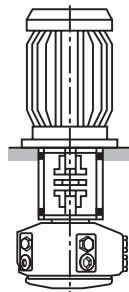

Fluid tank

- Adjust the useful capacity of the tank to the operating conditions
- The permissible fluid temperature must not be exceeded; if required, provide cooler

Lines and connections

- Remove protective plug from pump
- We recommend the use of seamless precision steel pipes according to DIN 2391 and pipe connections that can be loosened
- Select the clear width of pipes according to the connections (suction velocity 1 to 1.5 m/s)
- For inlet pressure, see page 5
- Thoroughly clean pipes and fittings before their installation

Recommendation for piping

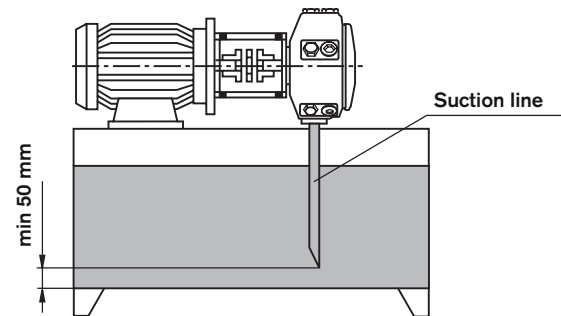

- The returning oil must **under no circumstances** be re-aspired directly, i.e. select the largest possible distance between suction and return line
- The return oil outlet must always be immersed in the oil
- Ensure suction-tight installation of the pipes

Filters

- If possible, use return line or pressure filters.
(Use suction filter only in conjunction with an underpressure switch/clogging indicator)

Hydraulic fluid

- Please observe our regulations according to data sheet RE 07075
- We recommend the use of branded hydraulic oils
- Different oil grades must not be mixed, since this can result in decomposition and deterioration of the lubricating properties
- The fluid must be changed at certain intervals depending on the operating conditions. This involves cleaning of the fluid tank from residues.

Engineering notes

Comprehensive notes and suggestions can be found in The Hydraulic Trainer, Volume 3 RE 00281, "notes on the planning and design of hydraulic systems".

For the use of radial piston pumps, we recommend that the notes given in the following be strictly observed.

Technical data

All technical data given depend on manufacturing tolerances and are valid in conjunction with certain boundary conditions.

Please note that certain tolerances are therefore possible, and that technical data may vary when boundary conditions (e.g. viscosity) are changed.

Characteristic curves

Characteristic curves for flow and required power.

When selecting the drive motor, take the max. possible operating data into account.

Noise

The noise pressure level values given on page 5 are measured in accordance with DIN 45635 part 26. This means that only the noise emitted by the pump is shown. Influences by the surroundings (such as place of installation, piping, etc.) were eliminated. The values always refer to only one pump.

Caution!

The power unit design and influences at the place of final installation of the pump result in the fact that the noise pressure level is usually 5 to 10 dB(A) higher than the value of the pump alone.

Commissioning notes

Bleeding

- All radial piston pumps of type PR4 are self-priming.
- Before initial commissioning, the pump must be bled in order to protect it from damage.
- **During initial commissioning, foaming oil must be drained by opening the pressure flange or the pressure line (if required, provide splash guard) while the pump is running in absolutely pressureless circulation. Only when bubble-free oil starts to flow out can the flange be re-tightened to the specified torque.**
- Should the pump not displace bubble-free oil after approx. 20 seconds, check the system again. When the operating values are reached, check the pipe connections for leakage. Check the operating temperature.

Commissioning

- Check that the system is thoroughly and properly installed.
- Observe the arrows for the direction of rotation of the motor and the pump.
- Start the pump up under no load and let it displace at zero pressure for some seconds in order to ensure sufficient lubrication.
- **The pump may in no case be operated without fluid!**

⚠ Important notes

- Adjustments, maintenance and repair of the pump may only be carried out by authorised, trained and instructed personnel!
- Use only genuine Rexroth spare parts!
- The pump may only be operated at the permissible data.
- The pump may only be operated when in perfect condition!
- When carrying out any work on the pump (e.g. installation or removal), the system must be switched off and depressurised!
- Unauthorised conversions or changes that affect safety and function are not permitted!
- Attach protective guards (e.g. coupling protection)!
- Any existing protective guards must not be removed!
- The generally valid safety regulations and regulations for the prevention of accidents must be strictly observed!

© This document, as well as the data, specifications and other information set forth in it, are the exclusive property of Bosch Rexroth AG. Without their consent it may not be reproduced or given to third parties.

The data specified above only serve to describe the product. No statements concerning a certain condition or suitability for a certain application can be derived from our information. The given information does not release the user from the obligation of own judgement and verification. It must be remembered that our products are subject to a natural process of wear and aging.