

## RE 29 591/06.02

Replaces: 03.93

### 4-way directional servo valve Type 4WS.2E...

Nominal size 16

Series 2X

Maximum operating pressure 210/315 bar

Maximum flow 320 L/min

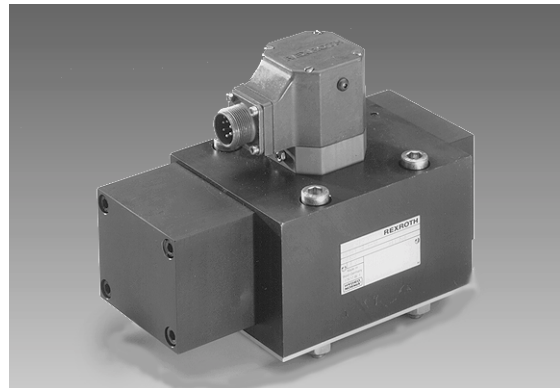

H/A 3013

Type 4WSE2ED 16-2X/...B... with mechanical and electrical feedback and integrated control electronics

### Overview of contents

Contents	Page
Features	1
Ordering details, preferred types	2 and 3
Symbols	3
Test unit	3
Function, section	4 and 5
Technical data	6 and 7
Control electronics	7
Plug-in connectors, electrical connections	8
Characteristic curves	9 to 13
Unit dimensions, subplates	14 and 15
Pilot oil supply and drain, flushing	16

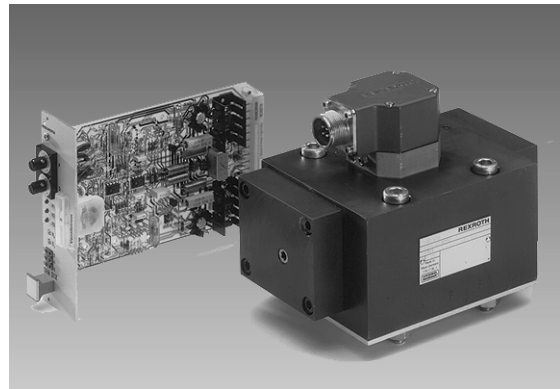

H/A 3012

Type 4WS2EM 16-2X/...B... with mechanical feedback and associated external control electronics (separate order)

### Features

- Valve for closed loop position, force and speed control
- Two stage servo valve with mechanical or mechanical and electrical feedback
- 1st stage as an orifice-flapper plate amplifier
- For subplate mounting, porting pattern to DIN 24 340 form A16 with port X, subplates to catalogue sheet RE 45 054 (separate order)
- Dry torque motor, no contamination of the solenoid gap by the pressure fluid
- Can also be used as a 3-way version
- Wear-free spool return element
- Three control variations
- Control:
  - External control electronics in eurocard format (separate order), see page 7
  - Or with the control electronics integrated into the valve
- The valves with integrated control electronics are calibrated and tested
- The pilot oil supply, internal/external, can be changed without dismantling the valve
- The control sleeve can be replaced
- Filter for the 1st stage is accessible from the outside by means of a plug



© 2002  
by Bosch Rexroth AG, Industrial Hydraulics

All rights reserved. No part of this document may be reproduced or stored, processed, duplicated or circulated using electronic systems, in any form or by any means, without the prior written authorisation of Bosch Rexroth AG. In the event of contravention of the above provisions, the contravening party is obliged to pay compensation.

This document was prepared with the greatest of care, and all statements have been examined for correctness. This document is subject to alterations for reason of the continuing further developments of products. No liability can be accepted for any incorrect or incomplete statements.

## Ordering details

		16	-2X /	B					E	V	*	
Electrically operated 2-stage 4-way servo valve											<b>7</b>	Further details in clear text
For <b>external</b> control electronics	= 4WS2E										<b>6</b>	V = FKM seals
With <b>integrated</b> control electronics	= 4WSE2E										<b>5</b>	<b>Spool overlap</b> E = 0 to 0.5 % negative
Mechanical feedback	= M											<b>Electrical connection</b>
Mechanical and electrical feedback (only with integrated electronics)	= D											Valve for <b>external</b> control electronics: <b>K8 = Without</b> plug-in connector with component plug for a 4-pin plug-in connector to VG 095 342
Nominal size 16	= 16											Valve with <b>integrated</b> control electronics: <b>K9 = Without</b> plug-in connector with component plug for a 6-pin plug-in connector to E DIN 43 563-AM6-3 Plug-in connector – separate order
Series 20 to 29 (20 to 29: unchanged installation and connection dimensions)	= 2X											<b>4</b> <b>Input pressure range for the 1st stage</b> <b>210 =</b> 10 to 210 bar <b>315 =</b> 10 to 315 bar
<b>Nominal flow</b> At a valve pressure differential $\Delta p = 70$ bar											<b>3</b>	<b>Pilot oil supply and drain</b> ET = Internal supply and drain (standard) T = External supply, internal drain
100 L/min	= 100											
150 L/min	= 150											
200 L/min (the tolerance of the flow/signal function on page 9 has to be taken into account!)	= 200											
<b>Coil or control data</b>											<b>2</b>	
Valves for <b>external</b> control electronics												
Coil No. 12 (50 mA/85 $\Omega$ per coil)	= 12											
Valves with <b>integrated</b> electronics												
Control: Command value $\pm 10$ mA/1 k $\Omega$	= 8											
Command value $\pm 10$ V/ $\geq 50$ k $\Omega$	= 9											

### 1 Nominal flow

The nominal flow refers to a 100 % command value signal at a 70 bar valve pressure differential (35 bar per control land). This valve pressure differential is to be considered as a reference value. Other values cause a change in the flow. Please take into account a possible nominal flow tolerance of  $\pm 10$  % (see flow/load function on page 9).

### 2 Electrical control data

Valves for **external** control electronics: The positioning signal must be generated by a current regulated output stage. See page 7 for servo amplifiers.

Valves with **integrated** control electronics: The command value can be applied as a voltage (ordering detail „9“) or for longer distances (> 25 m between the control and the valve) as a current (ordering detail „8“).

### 3 Input pressure for the pilot control

The pilot pressure must be maintained as constant as possible. Therefore an external pilot control via port X is often advantageous.

The dynamic response of the valve may be influenced using a higher pressure at X than at P.

### 4 Input pressure range

The system pressure must be maintained as constant as possible.

Pilot pressure range: 10 to 210 bar or 10 to 315 bar

With reference to the dynamics, within the permissible pressure range the frequency relationship must be taken into account.

### 5 Spool overlap

The spool overlap in % refers to the control spool nominal stroke.

Other spool overlaps on request!

### 6 Seal material

If other seal materials are required please consult us!

### 7 Details in clear text

Special requirements are to be specified in clear text. After receipt of the order they will be checked by the factory and the type code will be completed with an associated number.

## Test unit

**Test unit** (battery operated, optionally with a power supply) to catalogue sheet RE 29 681

**Attention:**

- Only for valves with external control electronics

### Test unit for proportional and servo valves with integrated control electronics

**Type VT-VET-1, series 1X** to catalogue sheet RE 29 685.

The test unit is used for the control and functional testing of proportional and servo valves with integrated electronics. It is suitable for testing valves with an operating voltage of  $\pm 15$  V or 24 V.

**The following operating modes are possible:**

- External operation → Linking the operating voltage and the command value from the control cabinet to the valve
- Internal/external operation → Command value is applied by the test unit; the operating voltage via the control cabinet
- Internal operation → Operating voltage via a separate power supply; the command value is applied by the test unit
- Command value is applied via a BNC socket → Optional operating voltage

### Preferred types (readily available)

#### Valves for external control electronics, mechanical feedback

Material No.	Type 4WS2EM
00769978	4WS2EM 16-2X/100B12ET315K8EV
00716550	4WS2EM 16-2X/150B12ET315K8EV
00960575	4WS2EM 16-2X/200B12ET315K8EV

#### Valves with integrated control electronics, mechanical feedback

Material No	Type 4WSE2EM
00769976	4WSE2EM 16-2X/100B9ET315K9EV
00769980	4WSE2EM 16-2X/150B9ET315K9EV
00769981	4WSE2EM 16-2X/200B9ET315K9EV

#### Valves with integrated control electronics, mechanical and electrical feedback

Material No.	Type 4WSE2ED
00769983	4WSE2ED 16-2X/100B9ET315K9EV
00769982	4WSE2ED 16-2X/150B9ET315K9EV
00769984	4WSE2ED 16-2X/200B9ET315K9EV

## Symbols

Simplified

#### Valves for external control electronics

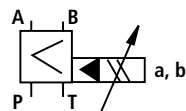

#### Valves with integrated control electronics

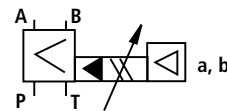

Detailed

#### Mechanical feedback

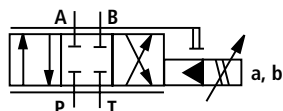

#### Electrical and mechanical feedback

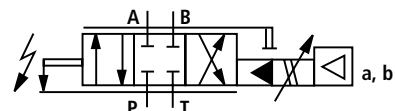

## Function, section

### 4WS(E)2EM 16-2X/...

The valve types 4WS(E)2EM... are electrically actuated, 2-stage servo directional valves with a porting pattern to DIN 24 340 form A16. They are primarily used for the closed loop control of position, force and velocity.

These valves comprise of an electro-mechanical convertor (torque motor) (1), a hydraulic amplifier (flapper jet principle) (2) and a control spool (3) in a sleeve (2nd stage), that is connected to the torque motor via a mechanical feedback.

Via an electrical input signal at the coils (4) of the torque motor, a force is generated via a permanent magnet at the armature (5) that, in conjunction with a torque tube, (6) generates a torque. Due to this the flapper plate (7), which is connected with the torque tube (6) via a rod, is moved out of the central position between the control orifices (8) a pressure differential now results which acts on the front face of the control spool. This pressure differential causes the spool to move, whereby the pressure connection is connected to an actuator connection and at the same time the other actuator connection is connected to the return connection.

The control spool is connected via a feedback spring (mechanical feedback) (9) to the flapper plate and torque motor. The control spool continues to change position until the torque feedback, via the feedback spring and the electro-magnetic torque of the torque motor are balanced, and the pressure differential at the flapper jet system becomes zero.

The stroke of the control spool and thus the flow through the pilot control valve is closed loop controlled in proportion to the electrical input signal. It has, however to be taken into account that the flow is dependent on the valve pressure differential.

### External control electronics, type 4WS2EM 16-2X/... (separate order)

External control electronics, (servo amplifier), are used to control the valve, they so amplify the analogue input signal (command value) that the controlled current output signal is capable of driving the valve.

### Integrated control electronics, types 4WSE2EM16-2X/... and 4WSE2ED 16-2X/...

For the amplification of the analogue input signal control electronics (10), which are specially matched to the valve, are integrated into the valve. They are built into the torque motor cover plate. The valve zero point can be adjusted by a potentiometer which is externally accessible.

### 4WSE2ED 16-2X/...

This type of valve is fitted with, in addition to the mechanical closed loop control via a feedback spring, an electrical spool position acquisition and control system. The spool position is obtained via an inductive position transducer (11). The position transducer signal is compared with the command value via the integrated control electronics (10). Any possible control deviation is electrically amplified and then passed onto the torque motor as a control signal. With the additional electrical feedback it is possible to obtain higher dynamic values in the small signal range than the purely mechanical version due to the electrical closed loop amplification. The mechanical feedback ensures that, in the case of failure of the electrical power supply, the spool is positioned in the zero range.

The valve is only available with integrated control electronics. The valve zero point can be adjusted by an externally accessible potentiometer.

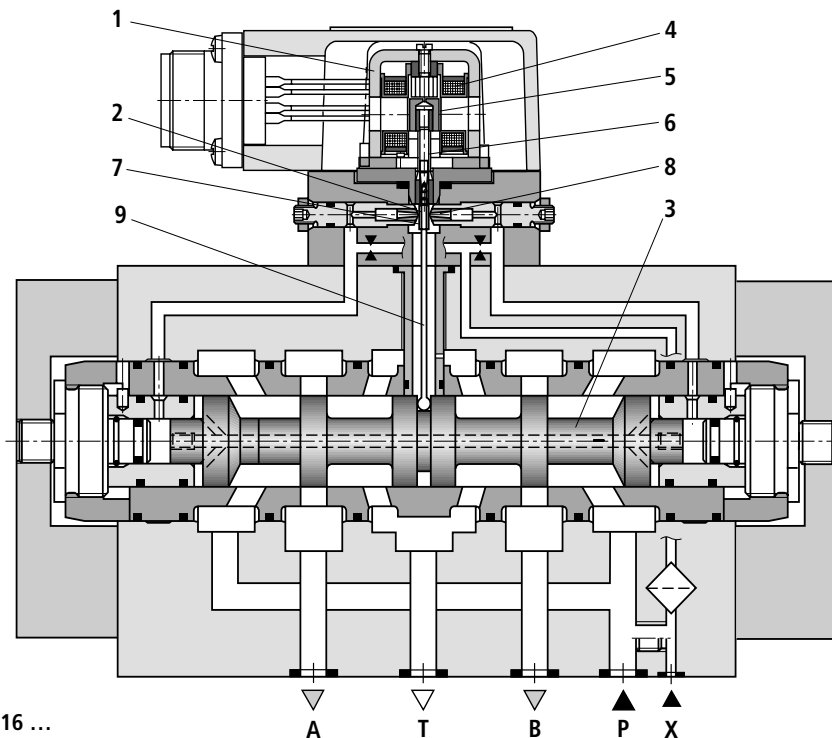

Type 4WS2EM 16 ...

Section

Type 4WSE2EM 16...

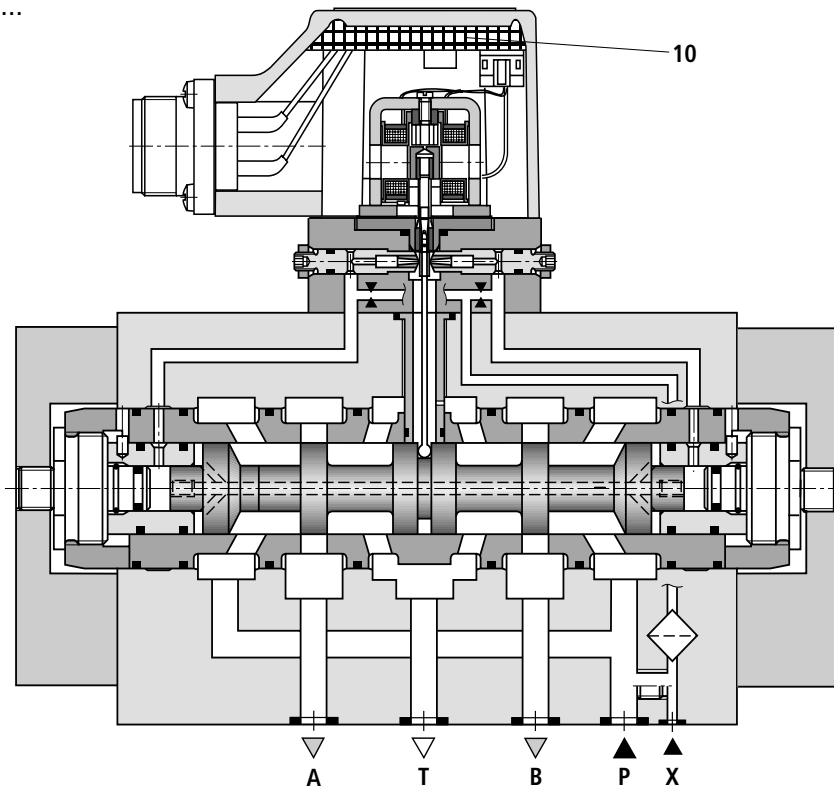

Type 4WSE2ED 16...

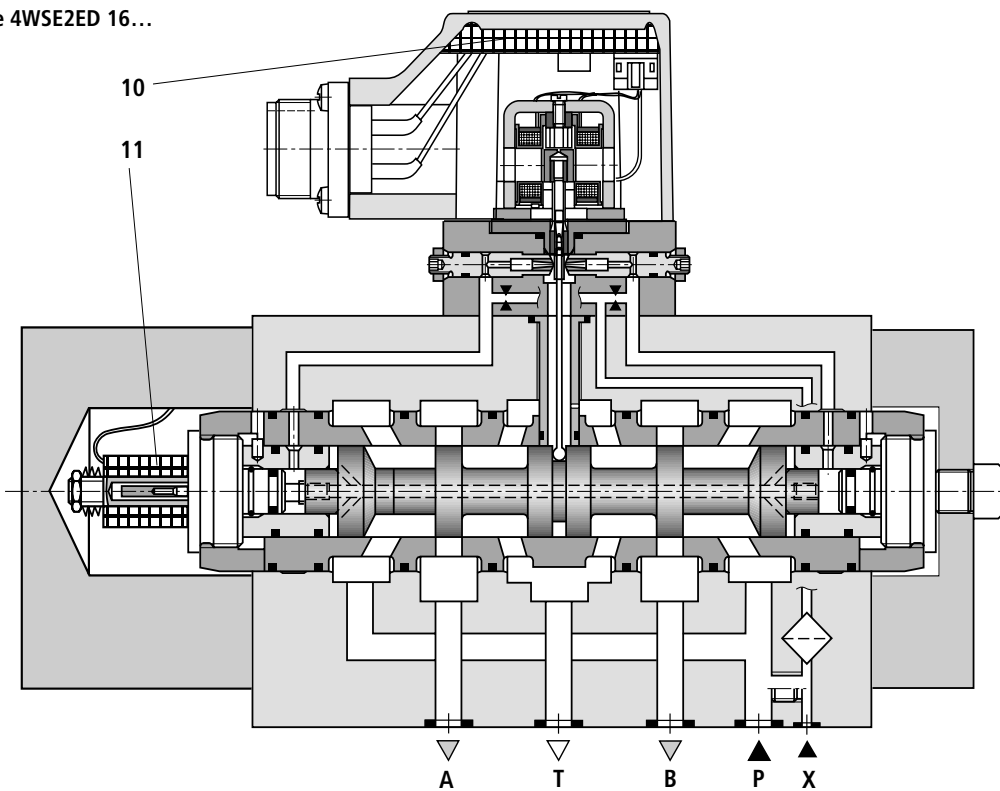

**Technical data** (for applications outside these applications, please consult us!)

**General**

Porting pattern	DIN 24 340 form A16		
Installation	Optional, it has however to be ensured that, when the system is started, the pilot control is supplied with an adequate pressure ( $\geq 10$ bar)!		
Storage temperature range	°C	-20 to +80	
Ambient temperature range	°C	-30 to +70, valve for external control electronics	
		-20 to +60, valve with integrated control electronics	
Weight	With mechanical feedback	kg	10.0
	With mechanical and electrical feedback and integrated control electronics	kg	11.0

**Hydraulic** (measured with a viscosity of  $\nu = 32 \text{ mm}^2/\text{s}$  and  $\vartheta = 40 \text{ °C}$ )

Operating pressure (ports A, B, P, X)	bar	10 to 210 or 10 to 315		
Return pressure, port T	bar	Pressure peaks $< 100$ , static $< 10$		
Pressure fluid	Mineral oil (HL, HLP) to DIN 51 524, other pressure fluids on request!			
Pressure fluid temperature range	°C	-20 to +80; preferably +40 to +50		
Viscosity range	$\text{mm}^2/\text{s}$	15 to 380; preferably 30 to 45		
Degree of contamination		Maximum permissible degree of contamination of the pressure fluid	A filter with a minimum retention rate of $\beta_x \geq 75$ is recommended without bypass valve and fitted as close as possible in front of the servo valve	
		Class 7	x = 5	
Zero flow $q_{vL}^{(1)}$ (spool overlap "E") measured without a dither signal	L/min	$\leq \sqrt{\frac{p}{70}} \cdot 3.5 \text{ L/min}^{(2)}$		
Nominal flow $q_{v \text{ nom}} \pm 10 \%^{(3)}$ at a valve pressure differential $\Delta p = 70 \text{ bar}^{(4)}$	L/min	100	150	200
Pressure gain (spool overlap „E“) at 1% change in stroke (starting from the hyd. zero point)	% von $p$	$\geq 65$	$\geq 80$	$\geq 90$
Control spool stroke	mm	0.6	0.9	1.2
Control spool area	$\text{mm}^2$	78		
Feedback system		Mechanical (M)	Mechanical and electrical (D)	
Hysteresis (dither optimised)	%	$\leq 1.5$	$\leq 0.5$	
Reversal range (dither optimised)	%	$\leq 0.3$	$\leq 0.2$	
Response sensitivity (dither optimised)	%	$\leq 0.2$	$\leq 0.1$	
Zero balance	in % von $I_{\text{nom}}$	$\leq 3$	$\leq 2$	
Zero offset at change in:	Pressure fluid temperature	%/20 °K	$\leq 1.5$	$\leq 1.2$
	Ambient temperature	%/20 °K	$\leq 1$	$\leq 0.5$
	Operating pressure	%/100 bar	$\leq 2$	$\leq 1$
	Return pressure 0 to 10 % of $p$	%	$\leq 1$	$\leq 0.5$

<sup>1)</sup>  $q_{vL}$  = Zero flow in L/min

<sup>2)</sup>  $p$  = Operating pressure in bar

<sup>3)</sup>  $q_{v \text{ nom}}$  = Nominal flow (complete valve) in L/min

<sup>4)</sup>  $\Delta p$  = Valve pressure differential in bar

**Technical data** (for applications outside these parameters, please consult us!)

Electrical		Mechanical (M)	Mechanical and electrical (D)
Feedback system			
Valve protection to EN 60 529			IP65
Signal type			Analogue
Nominal current per coil	mA	50	–
Resistance per coil	$\Omega$	85	–
Inductivity at 60 Hz and 100% nominal current:	Series circuit	H	–
	Parallel circuit	H	–
Recommended dither signal: $f = 400$ Hz		The amplitude value is dependent on the hydraulic system: a max. 5 % vom of the nominal current	

**Electrical**, external control electronics

Amplifier in (separate order) eurocard format	Type VT-SR2, to catalogue sheet RE 29 980
---	---

 **Note:** For details regarding the **environmental simulation test** covering EMC (electro-magnetic compatibility), climate and mechanical loading see RE 29 591-U (declaration regarding environmental compatibility).

**Plug-in connector**

Plug-in connector version **K8** (external control electronics) to VG 095 342 – separate order under Material No. **00002460**

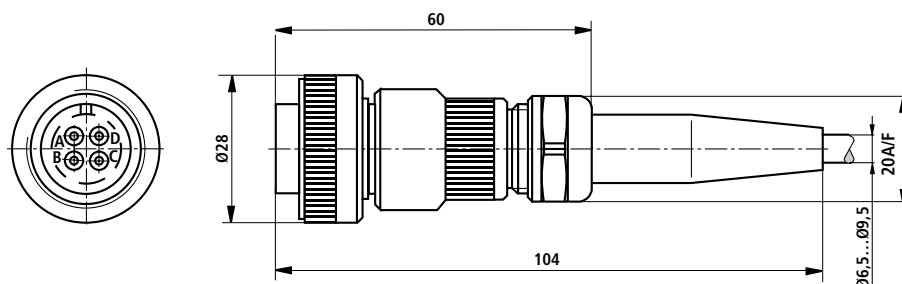

Plug-in connector version **K9** to E DIN 43 563-BF6-3/Pg11 separate order under Material No. **00223890** (metal version)

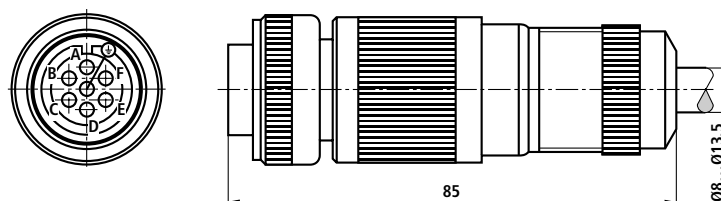

**Coil electrical connections in the component plug** (for valves with external control electronics)

The electrical connections can be either in parallel or series. Due to operational safety considerations and the low spool inductivity, we recommend a parallel circuit.

**Parallel circuit:** In the plug connect contacts A with B and C with D.

**Series circuit:** In the plug connect contacts B with C.

Electrical control from A (+) to D (–) results in a flow direction from P to A and B to T. Reversed electrical control results in a flow direction of P to B and A to T.

4 WS 2 EM 16-2X/...

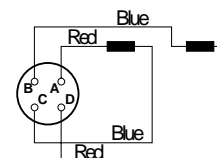

**Connection cable:**

4-core, 0.75 mm<sup>2</sup>, screened (e.g. cable type LiYCY 4x0.75mm<sup>2</sup>)  
Outside diameter 6.5 to 9.5 mm  
Only connect the screen to the supply side.

**Terminal connections 4 WSE2E .16.** (valves with integrated control electronics)

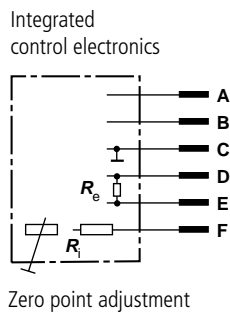

	Terminal connections	Current input signal	Voltage input signal
		Control "8"	Control "9"
Supply voltage ( $\pm 3\%$ )	A	+ 15 V	+ 15 V
	B	- 15 V	- 15 V
	C	$\perp$	$\perp$
Command value	D	$\pm 10\text{ mA}$ ; $R_e = 1\text{ k}\Omega$	$\pm 10\text{ V}$ ; $R_e \geq 50\text{ k}\Omega$
	E		
Measuring output for the control spool	F <sup>1)</sup>	Nom. stroke corresponds to approx. $\pm 10\text{ V}$ with respect to $\perp$ ; $R_i = 1\text{ k}\Omega$	
Current consumption at plug terminal	A	Max. 150 mA	Max. 150 mA
	B		
	D	$\pm 10\text{ mA}$	$\leq 0.2\text{ mA}$
	E		

<sup>1)</sup> For valves without electrical feedback terminal F is not connected.

**Supply voltage:**

$\pm 15\text{ V} \pm 3\%$ , residual ripple  $< 1\%$

**Command value:**

A command value at plug connection D = negative with respect to the plug connection E results in a flow from P to B and A to T.

Measurement output F has a negative signal with respect to  $\perp$  .

A command value at plug connection D = positive with respect to the plug connection E results in a flow from P to A and B to T.

Measurement output F has a positive signal with respect to  $\perp$  .

**Measurement output:**

The voltage signal  $U_f$  is proportional to the spool stroke.

**Note:** Electrical signals (e. g. actual value) taken via valve electronics must not be used to switch off the machine safety functions!

(Also see European standard "Safety requirements of fluid technology systems and components – hydraulics", prEN 982 !)

**Characteristic curves** (measured with HLP32,  $\vartheta_{oil} = 40\text{ }^{\circ}\text{C} \pm 5\text{ }^{\circ}\text{C}$ )

**Flow/load function** (tolerance  $\pm 10\%$ )  
at 100 % command value signal

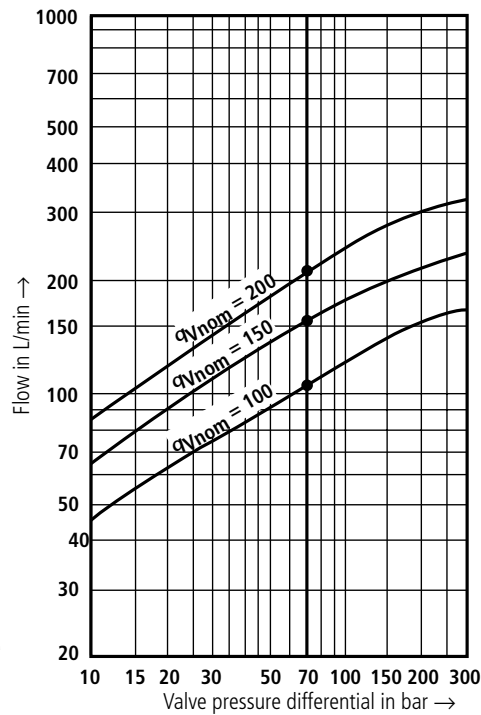

$\Delta p$  = Valve pressure differential  
(input pressure minus the  
return pressure and minus  
the load pressure)

**Tolerance range of flow/signal function**

at constant valve pressure differential

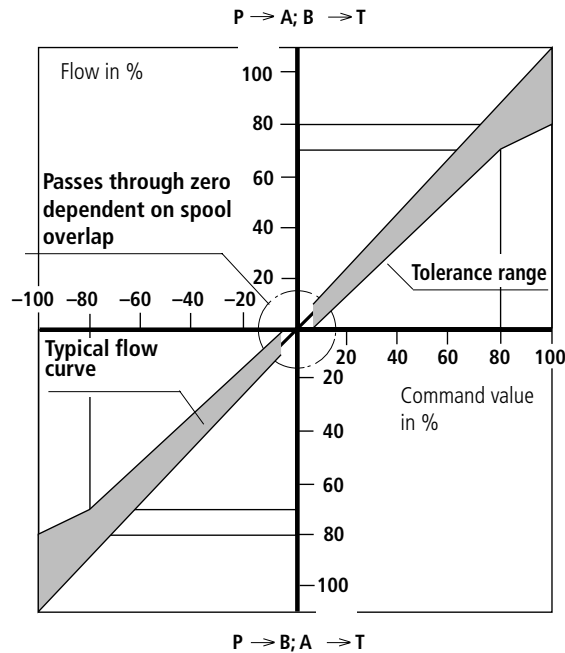

**Characteristic curves: type 4WS.2EM 16** (measured with HLP32,  $\vartheta_{oil} = 40\text{ °C} \pm 5\text{ °C}$ )

**Transient function with a 315 bar pressure stage**

Stop response without flow

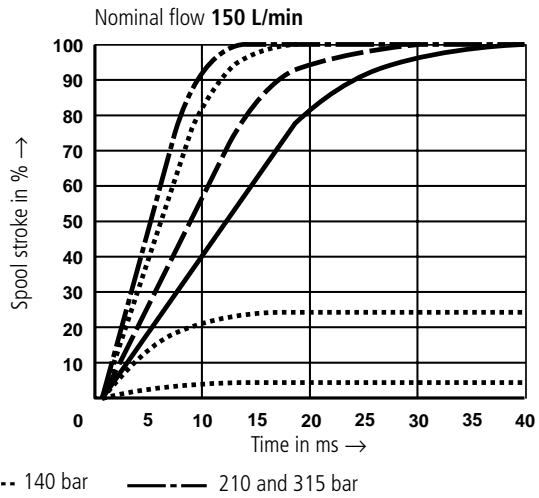
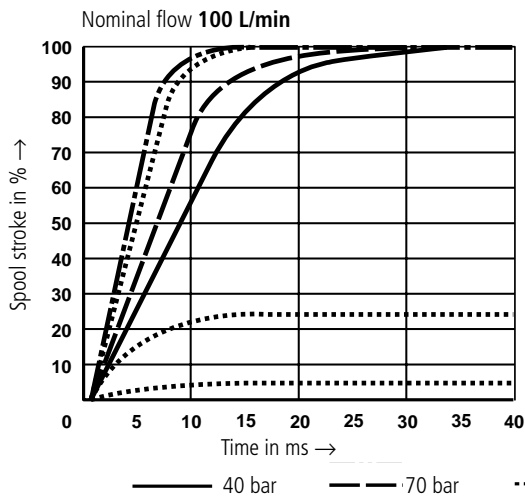

**Frequency response with a 315 bar pressure stage,  $p = 315\text{ bar}$**

Stroke frequency response without flow

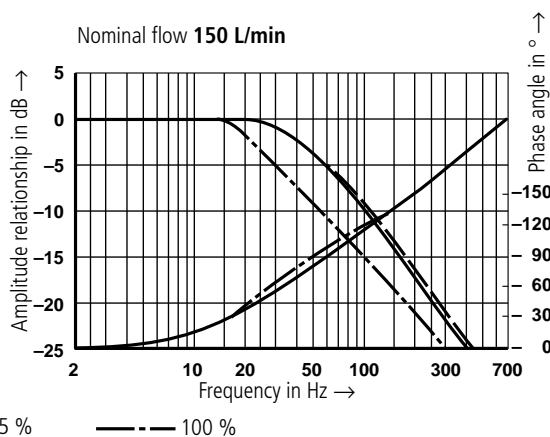
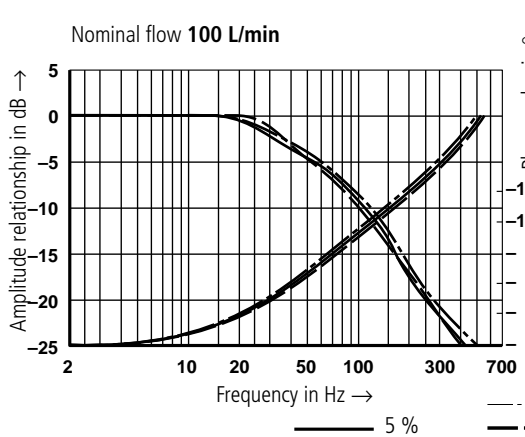

**Relationship of the corner frequency to the operating pressure  $p$**

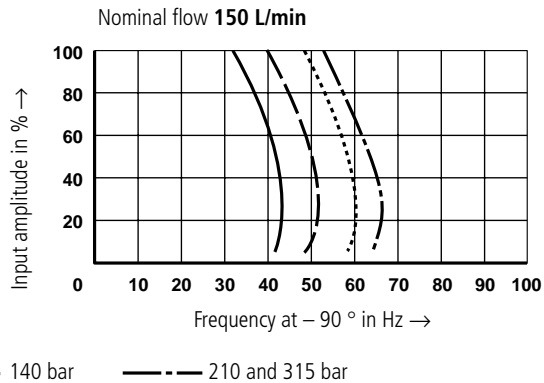
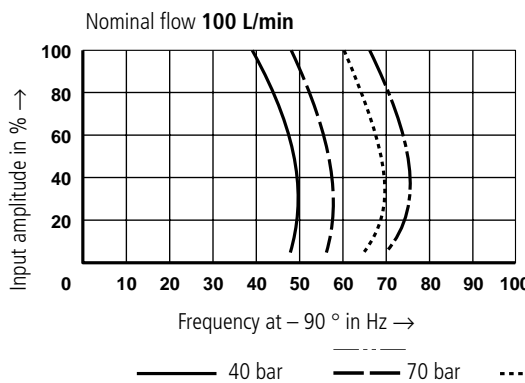

Output signal  $\hat{=}$  spool stroke without flow

**Characteristic curves: type 4WS.2EM 16** (measured with HLP32,  $\vartheta_{oil} = 40\text{ }^\circ\text{C} \pm 5\text{ }^\circ\text{C}$ )

Transient function with a 315 bar pressure stage

Step response without flow

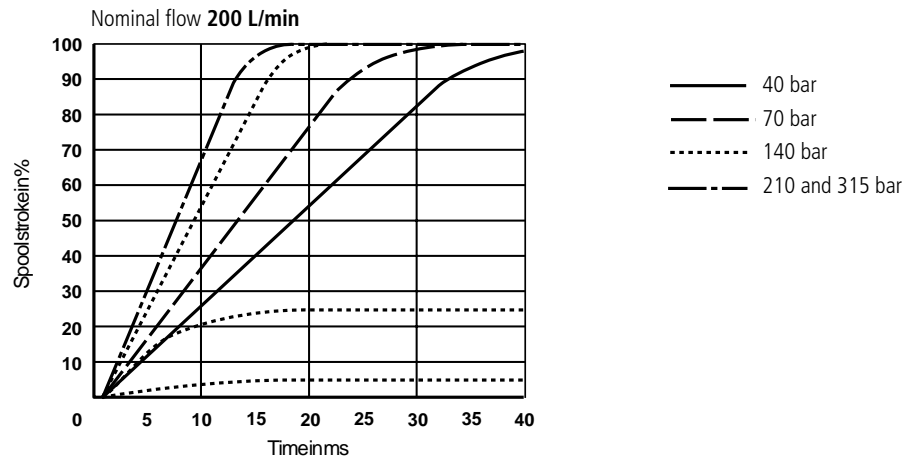

Frequency response with a 315 bar pressure stage,  $p = 315\text{ bar}$

Stroke frequency response without flow

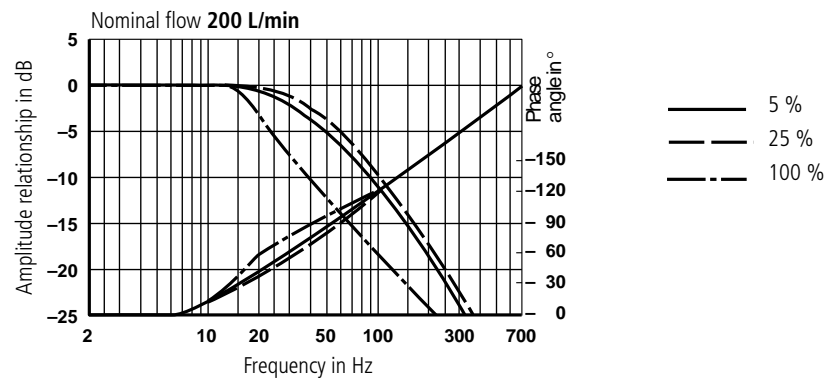

Relationship of the corner frequency to the operating pressure  $p$

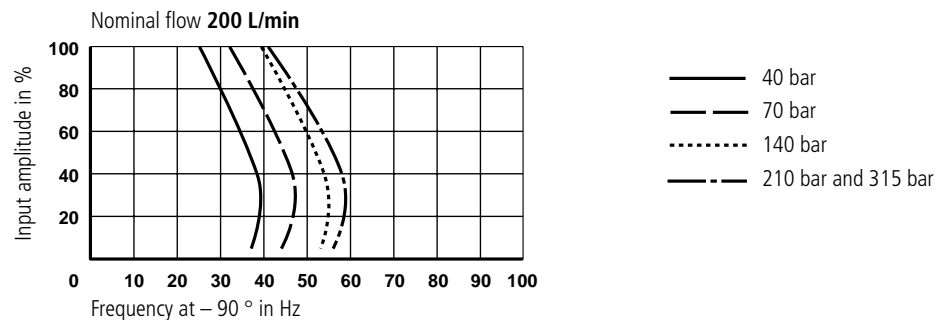

Output signal  $\hat{=}$  spool stroke without flow

**Characteristic curves: type 4WSE2ED 16** (measured with HLP32,  $\vartheta_{oil} = 40\text{ }^{\circ}\text{C} \pm 5\text{ }^{\circ}\text{C}$ )

**Transient function with a 315 bar pressure stage** Step response without flow

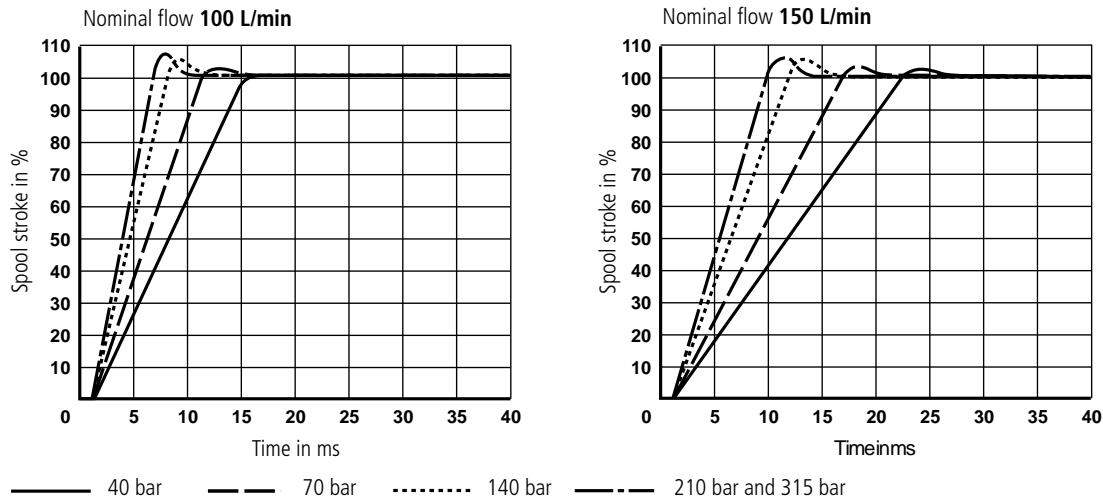

**Frequency response with a 315 bar pressure stage,  $p = 315\text{ bar}$**  Stroke frequency response without flow

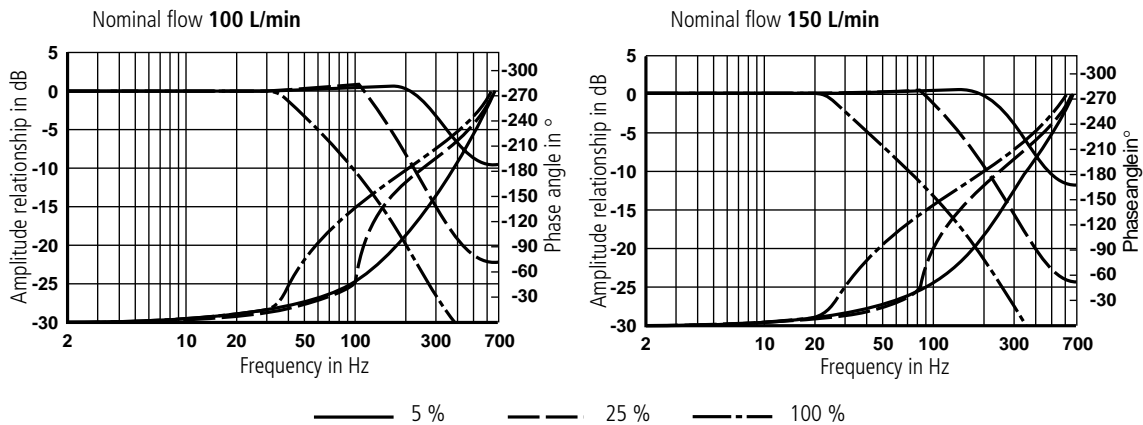

Relationship of the corner frequency to the operating pressure  $p$

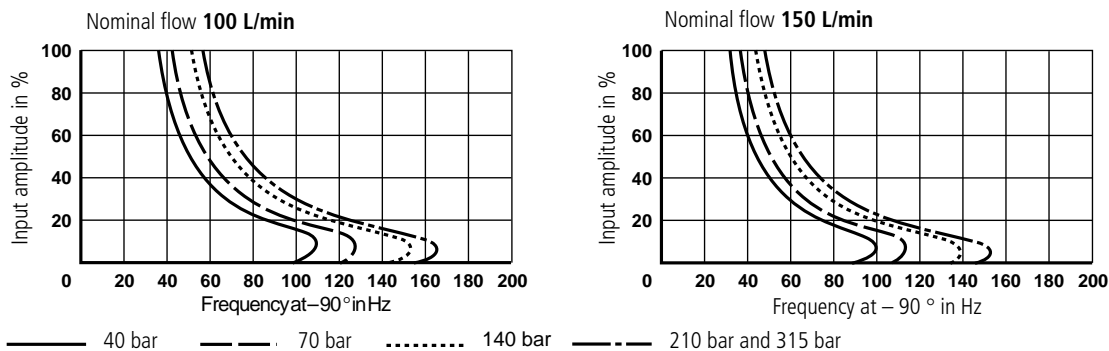

Output signal  $\triangleq$  spool stroke without flow

**Characteristic curves: type 4WSE2ED 16** (measured with HLP32,  $\vartheta_{oil} = 40\text{ }^{\circ}\text{C} \pm 5\text{ }^{\circ}\text{C}$ )

**Transient function with a 315 bar pressure stage**

Step response without flow

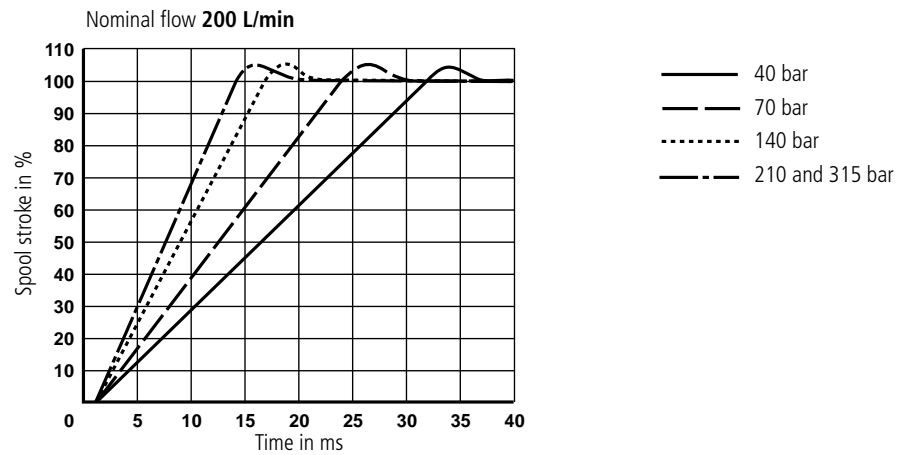

**Frequency response with a 315 bar pressure stage,  $p = 315\text{ bar}$**

Stroke frequency response without flow

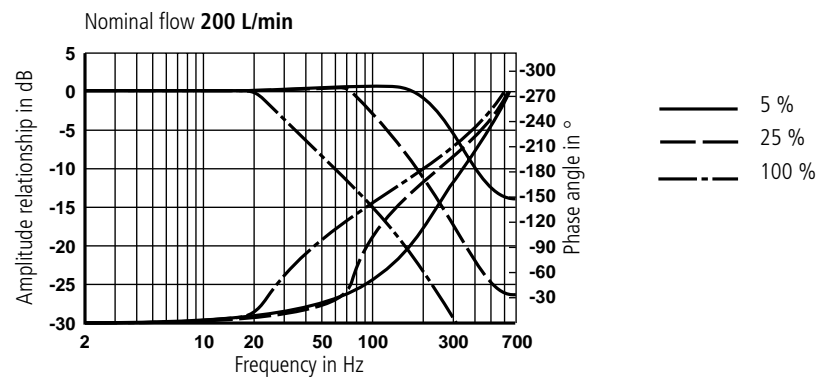

Relationship of the corner frequency to the operating pressure  $p$

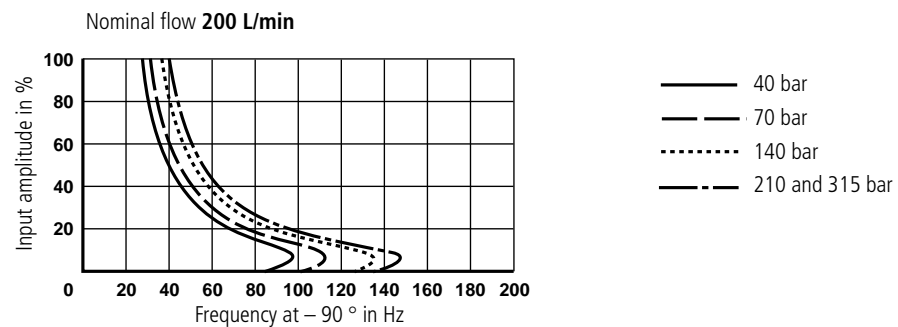

**Output signal  $\hat{=}$  spool stroke without flow**

**Unit dimensions: type 4WS.2EM 16** (dimensions in mm)

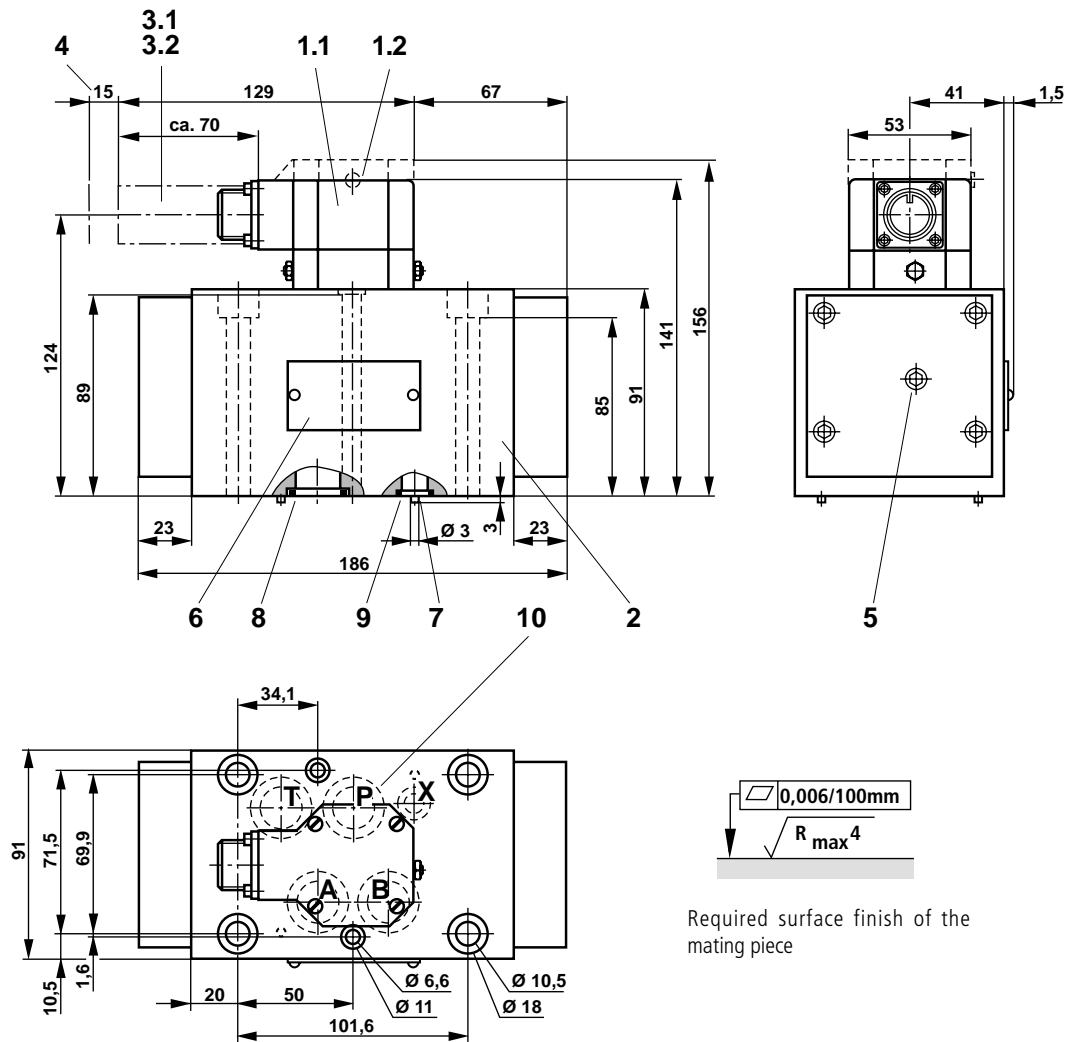

- 1.1 Pilot control (1st stage) **without** integrated control electronics (4 WS 2 EM 16)
- 1.2 Pilot control (1st stage) **with** integrated control electronics (4 WSE 2 EM 16)  
**Electrical zero point setting:**  
 Having removed the plug (2.5A/F) the zero point may be corrected via the potentiometer.
- 2 2nd stage
- 3.1 **Without integrated electronics:**  
 4-pin plug-in connector compatible with VG 095 342
- 3.2 **With integrated electronics:**  
 6-pin plug-in connector compatible with VG 095 342
- 4 Space required to remove the plug-in connector, take the connection cable into account!
- 5 For setting the hydraulic zero point on both sides  
 5A/F internal hexagon

- 6 Name plate
- 7 Locating pin (2 off)
- 8 Identical seal rings for ports A, B, P and T
- 9 Seal ring for port X
- 10 Porting pattern to DIN 24 340, form A 16

**Subplates** G 172/01 (G 3/4)  
 G 174/01 (G 1); G 174/08 (flange)  
 to catalogue sheet RE 45 056 must be ordered separately.

**Valve fixing screws** are included within the scope of supply.

4 off M10 x 100 DIN 912-10.9;  $M_A = 75 \text{ Nm}$   
 2 off M6 x 100 DIN 912-10.9;  $M_A = 15.5 \text{ Nm}$

**Unit dimensions: type 4WSE2ED 16** (dimensions in mm)

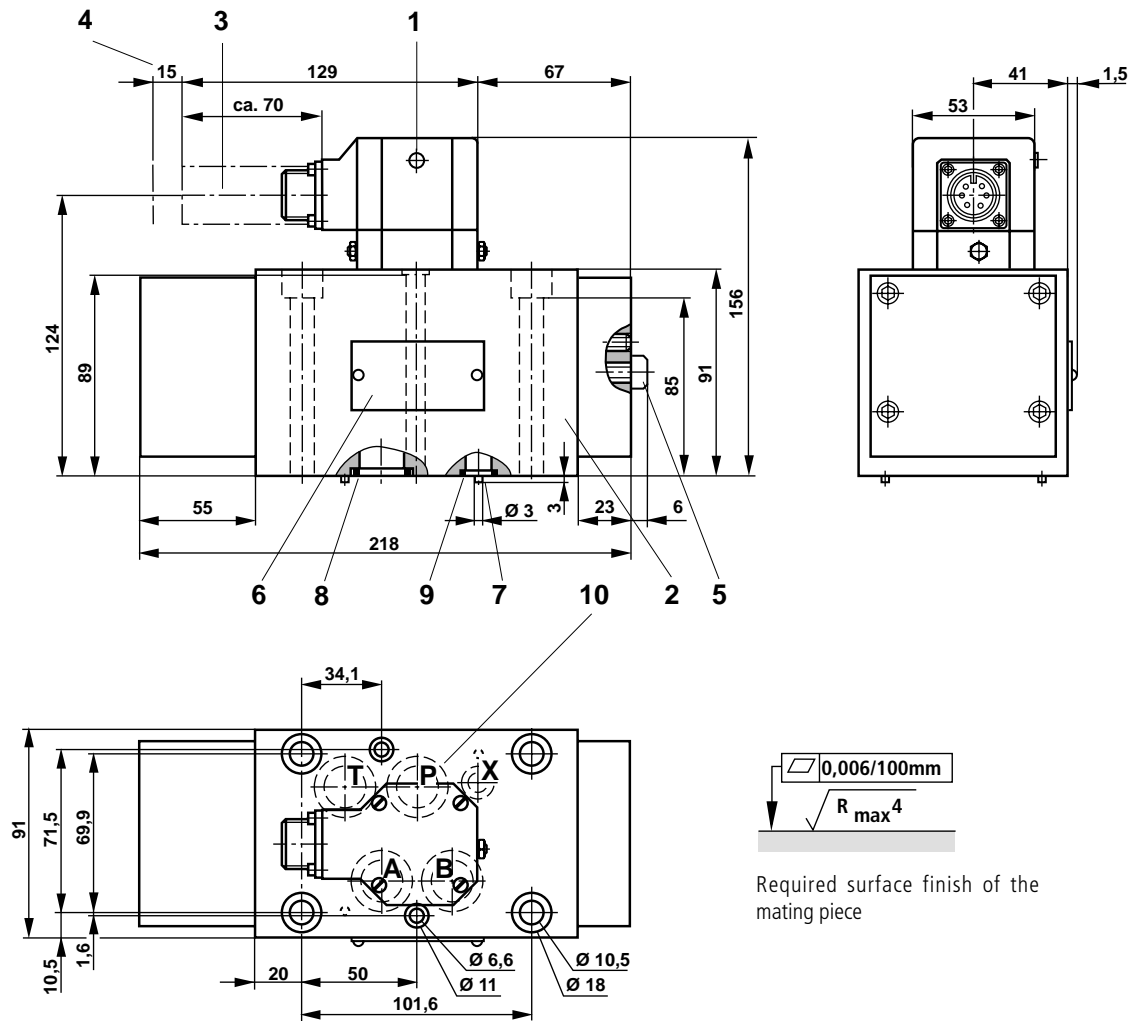

- 1 Pilot control (1st stage) with integrated control electronics  
**Electrical zero point setting:**  
Having removed the plug (2.5A/F) the zero point may be corrected via the potentiometer.
- 2 2nd stage
- 3 6-pin plug-in connector compatible to VG 095 342
- 4 Space required to remove the plug-in connector, take the connection cable into account!
- 5 Setting of hydraulic zero point via two screws 5A/F and 3A/F internal hexagon
- 6 Name plate
- 7 Locating pin (2 off)
- 8 Identical seal rings for ports A, B, P and T
- 9 Seal ring for port X
- 10 Porting pattern to DIN 24 340, form A 16

**Subplates**

G 172/01 (G 3/4)  
G 174/01 (G 1); G 174/08 (flange)

to catalogue sheet RE 45 056 must be ordered separately.

**Valve fixing screws** are included within the scope of supply.

4 off M10 x 100 DIN 912-10.9;  $M_A = 75$  Nm  
2 off M6 x 100 DIN 912-10.9;  $M_A = 15.5$  Nm

**Pilot oil supply** (pilot oil drain usually internal)

**Pilot oil supply**

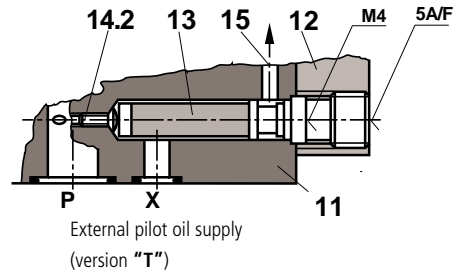
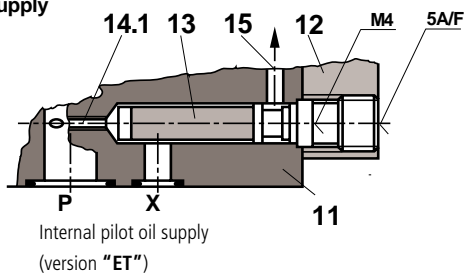

11 Main valve  
12 Cover

13 Filter  
Material No. **00649157**  
14.1 Open

14.2 Closed  
plug M6 x 10 DIN 906  
15 For 1st stage

**Flushing plate** (dimensions in mm)

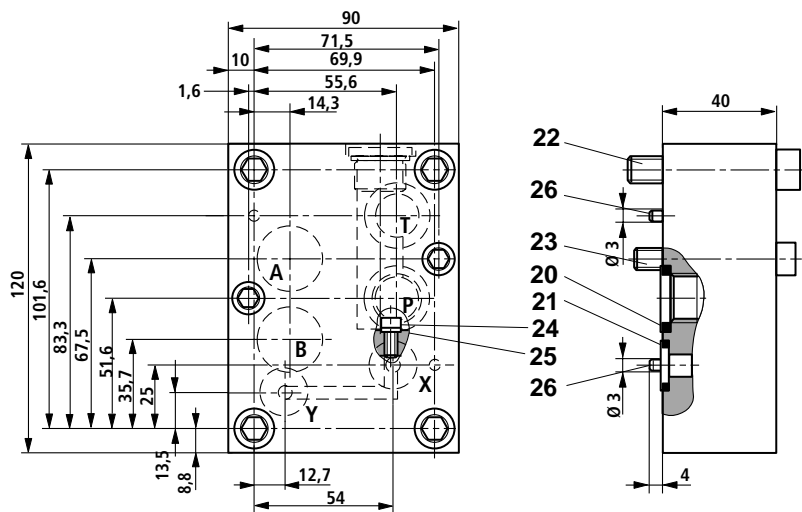

**Symbol**



With NBR seals  
Material No. **00308493**

- 20 Identical seal rings for ports A, B, P, T
- 21 Identical seal rings for ports X, Y
- 22 4 off S.H.C.S. M10 x 50 DIN 912-8.8  
(are included within the scope supply);  $M_A = 51$  Nm
- 23 2 off S.H.C.S. M6 x 50 DIN 912-8.8  
(are included within the scope supply);  $M_A = 10,4$  Nm
- 24 1 off S.H.C.S. M6 x 10 DIN 912-8.8  
(are included within the scope supply)
- 25 Seal ring
- 26 Locating pin (2 off)

In order to ensure that the servo valves functions correctly it is always necessary to flush the system before commissioning. As a guideline for the flushing time per system the following may be used:

$$t \geq \frac{V}{q_v} \cdot 5$$

$t$  = Flushing time in hours  
 $V$  = Tank contents in litres  
 $q_v$  = Pump flow in litres per minute

If the tank is subsequently filled with more than 10 % of the tank contents then the flushing process must be repeated.

A directional valve with a porting pattern to DIN 24 340 form A 16 is more suitable than a flushing plate. The actuator lines can also be flushed using this valve.

The data specified above only serve to describe the product. No statements concerning a certain condition or suitability for a certain application can be derived from our information. It must be remembered that our products are subject to a natural process of wear and ageing.