

For enquiries and technical support call

Electric Drives
and Controls

Hydraulics

Linear Motion and
Assembly Technologies

Pneumatics

Service

Rexroth
Bosch Group

4/3 directional servo-valve with mechanical position feedback

RE 29564/01.07
Replaces: 10.02

1/12

Type 4WS.2E

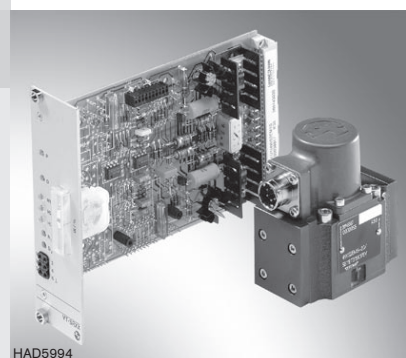
Size 6
Component series 2X
Maximum operating pressure 315 bar
Maximum flow 48 l/min

HAD5994

Table of contents

Contents	Page
Features	1
Ordering code	2
Symbols	2
Function, section	3
Technical data	4 and 5
Available accessories	5
Electrical connection	6
Characteristic curves	7 and 8
Unit dimensions	9 and 10
Flushing plate with porting pattern	11

Features

- Valve for controlling position, force, direction or velocity
- 2-stage servo-valve with mechanical feedback
- 1st stage as a nozzle-flapper plate amplifier
- For subplate mounting, porting pattern to ISO 4401-03-02-0-05
Subplates according to data sheet RE 45052 (separate order)
- Dry torque motor, no contamination of the solenoid gaps
through the hydraulic fluid
- Can also be used as 3-way version
- Wear-free spool return element
- Controlling
 - External control electronics in Euro-card format or of modular
design (separate order), see page 6
 - or control electronics integrated in the valve (OBE)
- Valve and integrated control electronics are adjusted and
tested
- Pressure chambers on the control bush with gap seal, no seal
ring wear
- Filter for 1st stage freely accessible from outside, see pages
9 and 10

Ordering code

	6	-2X/	B	ET	K17	V	*	
Electrically operated 2-stage servo-valve of 4-way design with mechanical feedback								Further details in clear text
For external control electronics								Seal material FKM seals, suitable for mineral oil (HL, HLP) to DIN 51524 ⁶⁾
With integrated control electronics (OBE)								Spool overlap ⁵⁾ D = 0 to 0.5 % positive E = 0 to 0.5 % negative
Size 6								Electrical connection K17 = Without mating connector, with male connector Mating connector – separate order, see page 6
Component series 20 to 29 (20 to 29: unchanged installation and connection dimensions)								Inlet pressure range ⁴⁾ 210 = 10 to 210 bar 315 = 10 to 315 bar
Nominal flow ¹⁾								ET = Internal pilot oil supply and drain ³⁾
2 l/min								
5 l/min								
10 l/min								
15 l/min								
20 l/min								
25 l/min								
(Observe tolerance field of the flow/signal function, see page 7)								
Valves for external control electronics ²⁾								
Coil no. 11 (30 mA/85 Ω x per coil)								
Valves with integrated control electronics								
Controlling:								
Command value ±10 mA								
Command value ±10 V								

1) Nominal flow

The nominal flow refers to a 100 % command value signal at a 70 bar valve pressure differential (35 bar per control land). The valve pressure differential must be observed as reference variable. Differing valves cause a change in the flow. It must be noted that the nominal flow tolerance is ±10 % (see flow/signal function on page 7).

2) Electrical control data

Valves for **external** control electronics: The actuating signal must be provided by a current-regulated output stage. For servo amplifiers, see page 6.

Valves with **integrated** control electronics: With integrated control electronics, the command value can be provided as voltage (ordering code "9") or, in the case of large distances of > 25 m between the control and the valve, as current (ordering code "8").

3) Pilot oil

This valve is only available with internal pilot oil supply and drain.

4) Inlet pressure range

The system pressure should be as constant as possible. With regard to dynamics, the frequency relationship must be taken into account within the permissible pressure of 10 to 210 bar or 10 to 315 bar.

5) Spool overlap

The spool overlap in % is referred to the nominal stroke of the control spool. Further spool overlaps on request.

6) Seal material

If you require another seal material, please consult us.

7) Details in clear text

Here, you can specify special requirements. These will be verified in the factory after receipt of your order and the type designation supplemented with an assigned number.

Symbols

Valves with OBE
(Example: 4WSE2EM 6-2X...ET...)

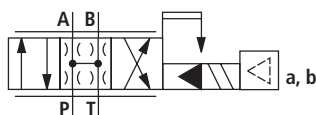

Valves without OBE
(Example: 4WS2EM 6-2X...ET...)

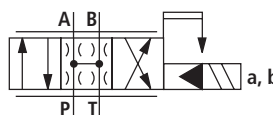

Function, section

4WS(E)2EM 6-2X/...

Valves of this type are electrically operated, 2-stage directional servo-valves with porting pattern to ISO 4401-03-02-0-05. They are mainly used for the closed-loop control of position, force, pressure or velocity.

These valves consist of an electromechanical converter (torque motor) (1), a hydraulic amplifier (nozzle flapper plate principle) (2) and a control spool (3) in a bush (2nd stage), which is connected to the torque motor via a mechanical feedback.

As a result of an electrical input signal applied at coils (4) of the torque motor, a force is generated by a permanent magnet that acts on armature (5), which generates a torque in conjunction with a bending tube (6). This causes flapper plate (7), which is connected by a pin to the bending tube (6), to be moved from the central position between the two control nozzles (8), and a pressure differential occurs across the front faces of the control spool (3). The pressure differential causes a change in the position of the spool, which results in the connection of the pressure port with an actuator port and, at the same time, in the connection of the other actuator port with the return flow port.

The control spool is connected with the flapper plate or the torque motor with the help of a bending spring (mechanical feedback) (9). The position of the spool is changed until the

torque fed back by the bending tube and the electromagnetic torque of the torque motor are balanced, and the pressure differential across the nozzle flapper plate system becomes zero.

The stroke of the control spool and hence the flow through the servo-valve is therefore controlled in proportion to the electrical input signal. It must be noted that the flow depends on the valve pressure drop.

Type 4WS2EM 6-2X/... for external control electronics

For controlling the valve, an external control electronic control (servo-amplifier) is used, which amplifies an analogue input signal (command value) to a level required for the output signal to provide a current-regulated control of the servo-valve.

Type 4WSE2EM 6-2X/... with OBE

For the amplification of the analogue input signal, a control electronics (10), which is matched specifically to this valve type, is integrated in the valve. It is mounted to the male connector (11) in the cap of the torque motor.

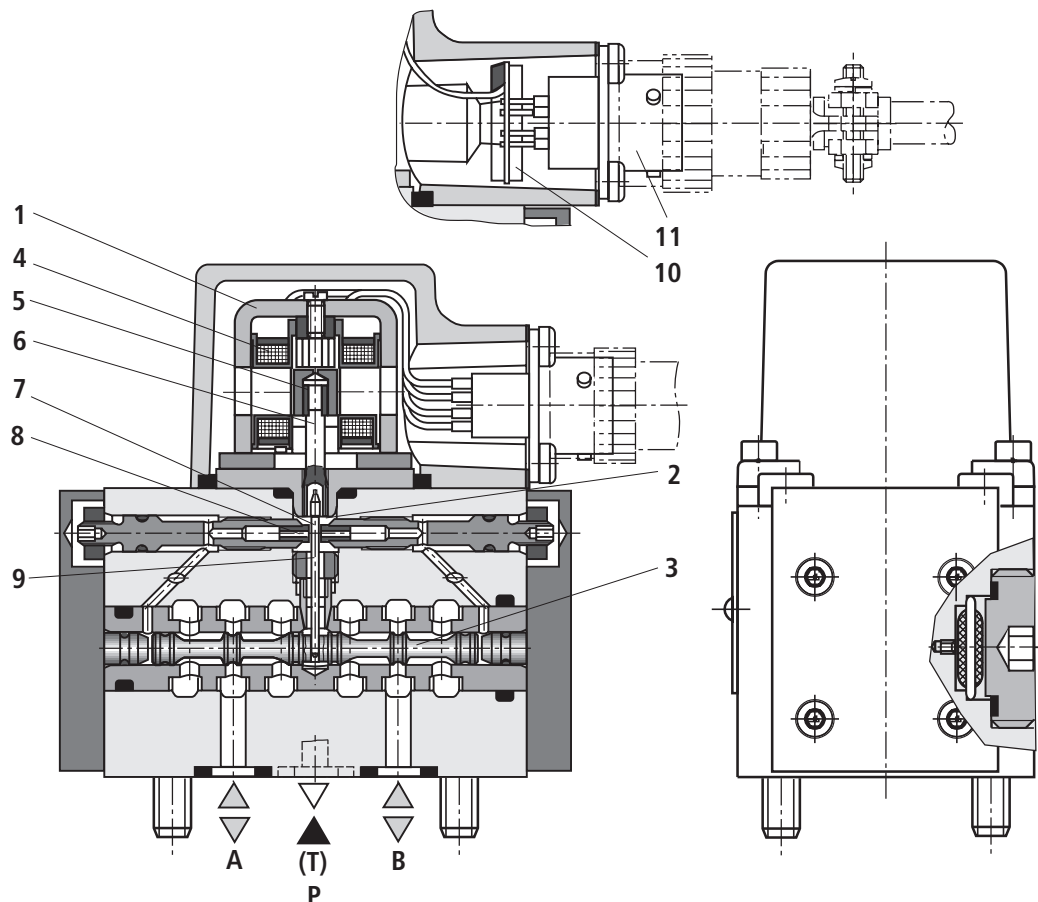

Technical data (for applications outside these parameters, please consult us!)

General

Weight	kg	1.1
Porting pattern		ISO 4401-03-02-0-05
Installation orientation		Optional (Make sure that during start-up of the system, the valve is supplied with sufficient pressure ≥ 10 bar!)
Storage temperature range	°C	-20 to +80
Ambient temperature range	°C	-20 to +60, valve with OBE -30 to +100, valve without OBE

Hydraulic

Operating pressure	- Ports A, B, P	bar	10 to 210 or 10 to 315
Return flow pressure	- Port T	bar	Pressure peaks < 100, steady-state < 10
Zero flow $q_{V,L}$ ¹⁾ with spool overlap E measured without dither signal		l/min	$\sqrt{p_p/70 \text{ bar}} \cdot (0.4 \text{ l/min} + 0.02 \cdot q_{Vnom})$ ^{2); 3)}
Nominal flows $q_{Vnom} \pm 10\%$ at valve pressure differential $\Delta p = 70$ bar		l/min	2; 5; 10; 15; 20; 25
Max. possible control spool stroke with mechanical end position (in the event of a failure) referred to nominal stroke		%	120 to 170
Hydraulic fluid			Mineral oil (HL, HLP) to DIN 51524; other hydraulic fluids on request
Hydraulic fluid temperature range preferably +40 to +50 °C		°C	-30 to +80, for valve with OBE -30 to +100, for valves without OBE
Viscosity range		mm ² /s	15 to 380, preferably 30 to 45
Permissible max. degree of contamination of the hydraulic fluid - cleanliness class to ISO 4406 (c)			Class 18/16/13 ⁴⁾
Feedback system			Mechanical
Hysteresis (dither-optimised)		%	≤ 1.5 to $p_p = 210$ bar ³⁾
Range of inversion (dither-optimised)		%	≤ 0.2 to $p_p = 210$ bar ³⁾
Response sensitivity (dither-optimised)		%	≤ 0.2 to $p_p = 210$ bar ³⁾
Pressure intensification at 1 % spool stroke change (from hydraulic zero point)		% of p_p ³⁾	≥ 50
Zero balancing current over the entire operating pressure range		%	≤ 3 , long term ≤ 5
Zero drift in the case of a change in:			
	Hydraulic fluid temperature	% / 20 °C	≤ 1
	Ambient temperature	% / 20 °C	≤ 1
	Operating temperature 80 to 120 % of p_p ³⁾	% / 20 °C	≤ 1
	Return flow pressure 80 to 10 % of p_p ³⁾	% / bar	≤ 1

¹⁾ $q_{V,L}$ = nominal flow in l/min

²⁾ q_{Vnom} = nominal flow in l/min

³⁾ p_p = operating pressure in bar

⁴⁾ The cleanliness classes specified for components must be adhered to in hydraulic systems. Effective filtration prevents malfunction and, at the same time, prolongs the service life of components.

For the selection of filters, see data sheets RE 50070, RE 50076 and RE 50081.

Technical data (for applications outside these parameters, please consult us!)**Electrical**

Type of protection to EN 60529	IP 65 with mating connector correctly mounted and locked		
Type of signal	Analogue		
Nominal current per coil	mA	30	
Resistance per coil	Ω	85	
Inductivity at 60 Hz and 100 % nominal current	Series connection	H	1.0
	Parallel connection	H	0.25
Superimposed dither required in the case of controlling with non-Bosch Rexroth amplifiers: $f = 400$ Hz	Magnitude of the amplitude depending on the hydraulic system: max. 3 % of nominal current		

External control electronics

Servo-amplifier (separate order)	Euro-card format	analogue	Type VT-SR2-1X/-60 according to data sheet RE 29980
	Modular design	analogue	Type VT 11021 according to data sheet RE 29743

The coils of the valve may only be connected to these amplifiers in a parallel connection!

 **Note!** For details with regard to **environment simulation testing** in the fields of EMC (electromagnetic compatibility), climate and mechanical stress, see RE 29564-U (declaration on environmental compatibility).

Available accessories

Service case with test unit for servo, proportional and high-response valves with integrated electronics, type VT-VETSY-1 according to data sheet RE 29685.

Service case with test unit for servo-valves for external electronics, type VT-SVTSY-1 according to data sheet RE 29681.

Electrical connection, external control electronics (example of parallel circuit)

Type 4WS2EM 6-2X/...

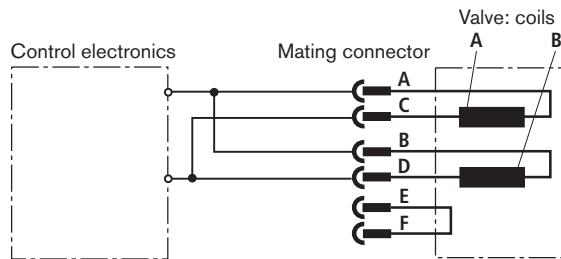

The coils are connected in parallel in the mating connector or on the amplifier (see figure).

For a serial connection, contacts B and C must be connected. Bridge E-F can be used for the electrical recognition of the correct connection of the male connector or for cable break detection.

Electrical controlling from A (+) to D (-) results in a direction of flow from P → A and B → T. Reverse electrical controlling results in a direction of flow from P → B and A → T.

Electrical connection, integrated control electronics

Type 4WSE2EM 6-2X/...

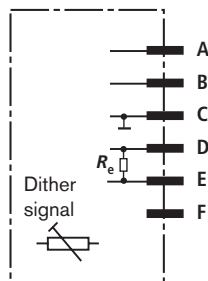

	Pin assignment of mating connector	Current control	Voltage control
		Control "8"	Control "9"
Supply voltage (tolerance ±3 %, residual ripple content < 1 %)	A	+15 V, max. 150 mA	+15 V max. 150 mA
Current consumption	B	-15 V, max. 150 mA	-15 V max. 150 mA
	C	⊥	⊥
Command value	D	±10 mA R _i = 1 kΩ	±10 V R _i ≥ 8 kΩ I _i = 1i2 mA
Command value reference	E		
	F	Not assigned	

Command value at mating connector connection D = positive against mating connector connection E results in a direction of flow from P → A and B → T.

Command value at mating connector connection D = negative against mating connector connection E results in a direction of flow from P → B and A → T.

Note: Electrical signals brought out via control electronics must not be used for switching off safety-relevant machine functions! (See also European standard EN 982, "Safety requirements for fluid power systems and their components - hydraulics").

Electrical connection, mating connector

Plug-in connector, separate order stating Material no. **R900005414**

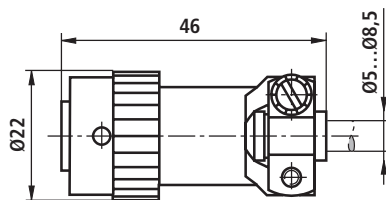

Plug-in connector, separate order stating Material no. **R901043330**

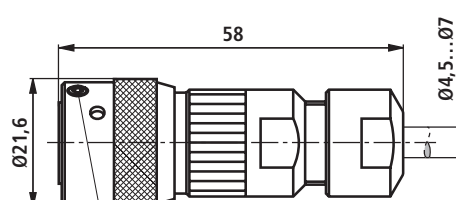

Locking: Grub screw M3, M_t = 0.3 Nm

Connection cable:

4- or 6-wire, 0.75 mm², shielded, with litz wires to DIN VDE 0812 (e.g. cable type LIYCY 4 or 6 x 0.75 mm²)

Characteristic curves (measured with HLP32, $\vartheta_{oil} = 40\text{ °C} \pm 5\text{ °C}$)

Flow/load function (tolerance $\pm 10\%$) at 100% command value signal

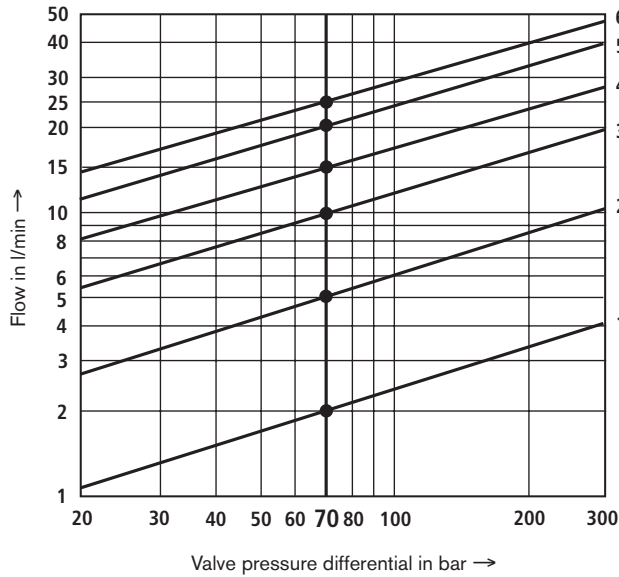

Ordering code	Nominal flow	Curve
2	2 l/min	1
5	5 l/min	2
10	10 l/min	3
15	15 l/min	4
20	20 l/min	5
25	25 l/min	6

$\Delta p =$ Valve pressure differential (inlet pressure p_p minus load pressure p_L minus return flow pressure p_r)

Tolerance field of flow/signal function at constant valve pressure differential Δp

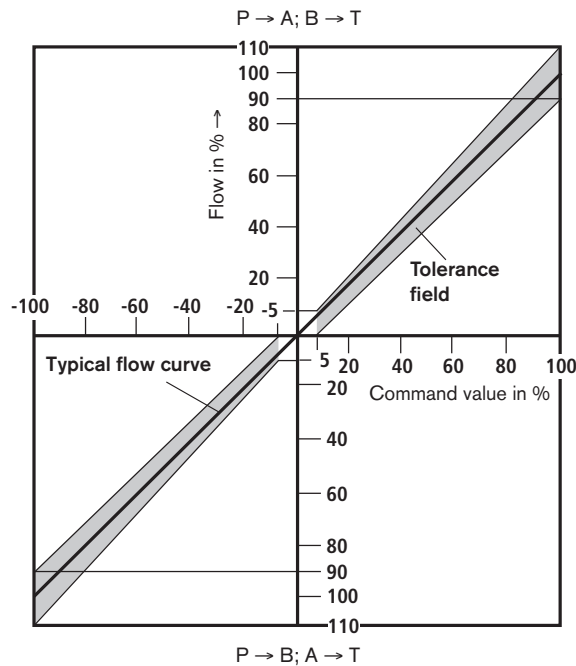

Characteristic curves (measured with HLP32, $\vartheta_{oil} = 40\text{ °C} \pm 5\text{ °C}$)

Transient function with pressure stage 315 bar

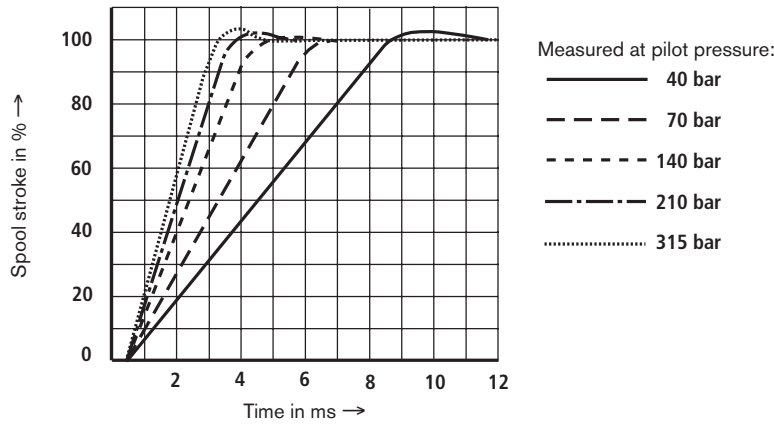

Frequency response with pressure stage 315 bar

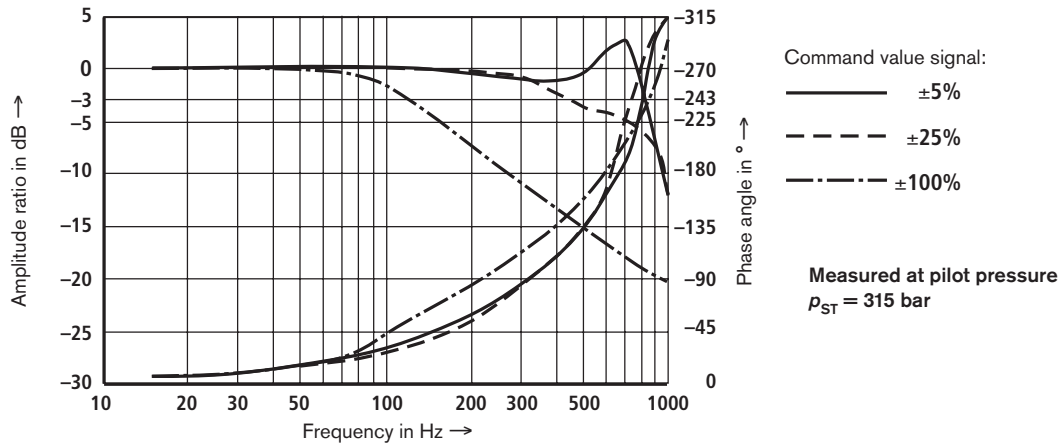

Dependence of frequency at -90° on operating pressure p and input amplitude

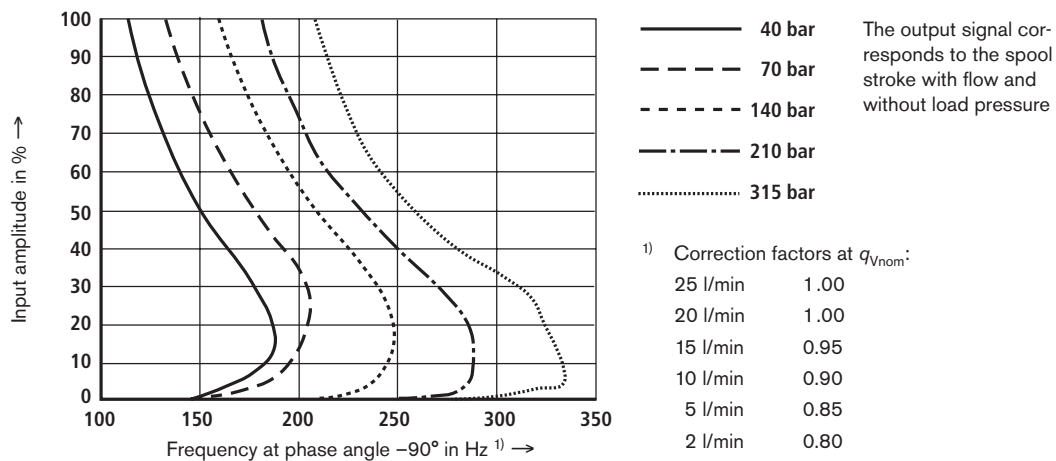

Unit dimensions: Types 4WS2EM 6 and 4WSE2EM 6 (nominal dimensions in mm)

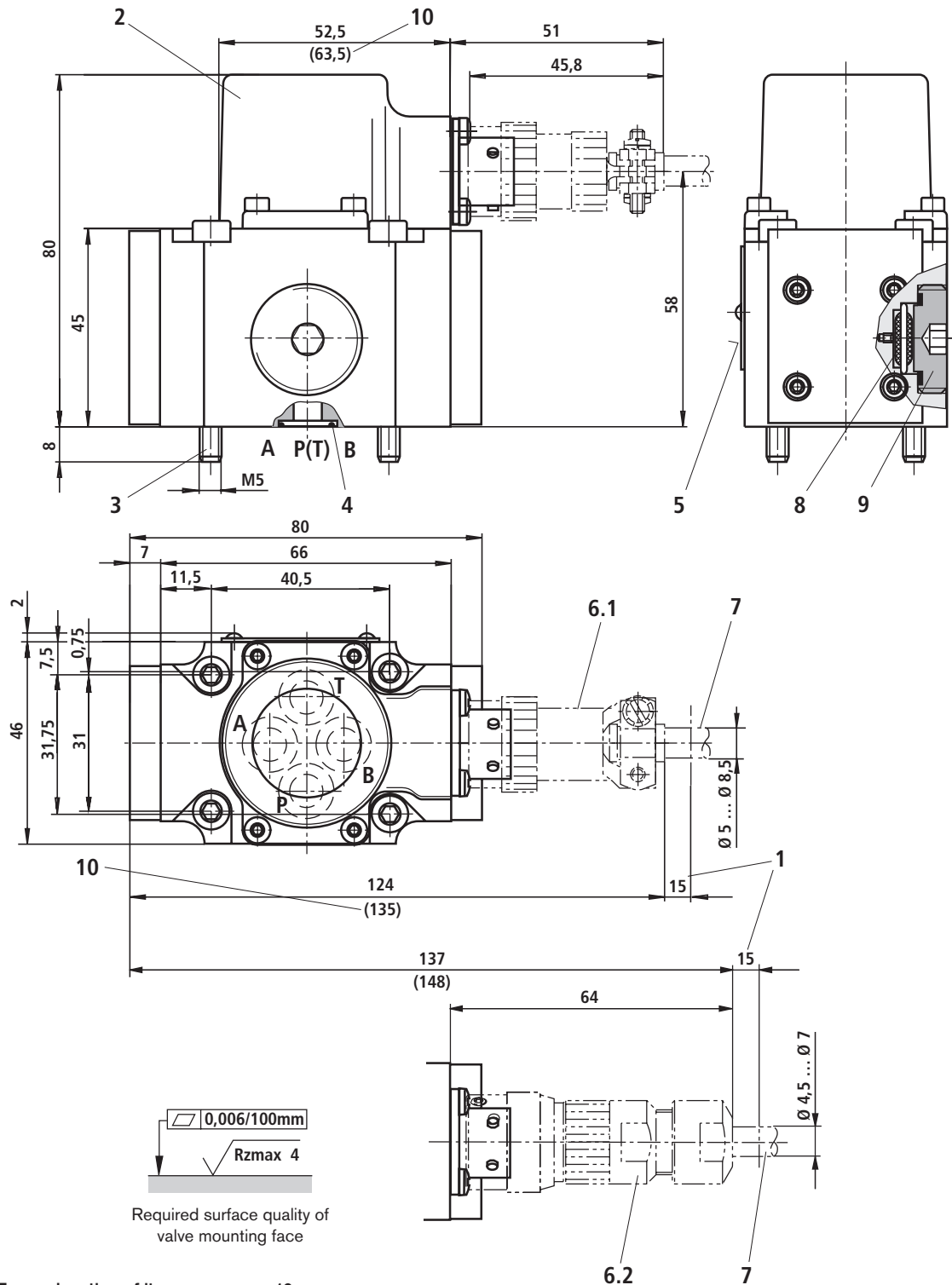

For explanation of items, see page 10

Flushing plate with porting pattern to ISO 4401-03-02-0-05 (nominal dimensions in mm)

Symbol



with FKM seals, Material no. **R900936049**, weight: 0.6 kg

- 1 4 off R-rings 9.81 x 1.5 x 1.78
- 2 Mounting screws
(included in the scope of supply)

For strength reasons, use exclusively the following valve mounting screws:

4 hexagon socket head cap screws
ISO 4762-M5 x 40-10.9-fZn-240h-L
 (friction coefficient 0.09-0.14 – to VDA 235-101)
 $M_T = 7 \text{ Nm} \pm 10 \%$

To ensure the proper operation of servo-valves, it is indispensable to flush the system before commissioning.

The following equation provides a guideline for the flushing time per system:

$$t \geq \frac{V}{q_v} \cdot 5$$

t = flushing time in h

V = tank capacity in l

q_v = pump flow in l/min

When topping up more than 10 % of the tank capacity, repeat the flushing process.

Better than the use of a flushing plate is a directional valve with connection to ISO 4401-03-02-0-05. This valve can also be used for flushing the actuator ports. See also data sheet RE 07700.

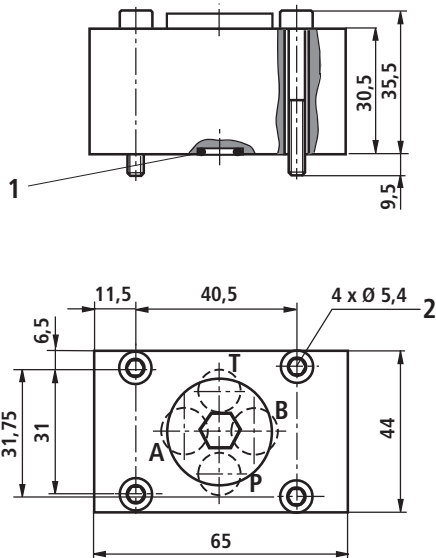

Notes

© This document, as well as the data, specifications and other information set forth in it, are the exclusive property of Bosch Rexroth AG. It may not be reproduced or given to third parties without its consent. The data specified above only serve to describe the product. No statements concerning a certain condition or suitability for a certain application can be derived from our information. The information given does not release the user from the obligation of own judgment and verification. It must be remembered that our products are subject to a natural process of wear and aging.

HYQUIP

New Brunswick Street Horwich Bolton BL6 7JB UK
Tel: +44 (0)1204 699959 Fax: +44 (0)1204 699542
Email: enquiries@hyquip.co.uk Web: www.hyquip.co.uk