

## 4/3 servo directional control valve with mechanical position feedback

**RE 29564-XN-102-B2/11.06**  
Replaces: 10.04

Type 4WS2EM 6...XN...-102

Nominal size 6  
Unit series 2X  
Maximum operating pressure 315 bar  
Maximum flow rate 48 l/min

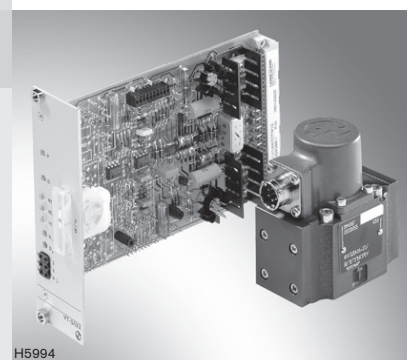

**ATEX units**  
**For potentially explosive atmospheres**

**Part II Technical Data Sheet**



**Information on explosion protection:**

Range of application in accordance with the  
Explosion Protection Directive and type of protection to  
EN 50014:1997+A1+A2

- Range of application as per Directive RL 94/9/EG
- **II3G:** Type of protection EEx nA II T5 to EN 50021:1999
- II3D:** Degree of protection IP 65, T100 °C to  
EN 50281-1-1:1998+A1

### What you need to know about these Operating Instructions

These Operating Instructions apply to the explosion-proof version of Rexroth valves,  
and consist of the following three parts:

- Part I General Information RE 07010-X-B1
- Part II Technical Data Sheet RE 29564-XN-102-B2
- Part III Product-specific Instructions RE 29564-XN-102-B3

**Mat. No. R901035209**

You can find further information on the correct handling of Rexroth hydraulic products in our publication  
"General Product Information for Hydraulic Products", RE 07008.

## Overview of Contents

---

Contents	Page
Features	2
Ordering data and scope of delivery	3
Symbol	3
Function, sectional diagram	4
Technical data	5, 6
Information on explosion protection	6
External trigger electronics	6
Plug-in connector	6
Electrical connection	6
Characteristic curves	7, 8
Unit dimensions	9
Flushing plate	10

## Features

---

- Servo directional control valve for proper use in potentially explosive atmospheres of Zones 2 and 22
- Valve for closed-loop position, draft, pressure and velocity control
- 2-stage servo valve with mechanical return
- 1st stage in the form of a jet/flapper plate amplifier
- For subplate mounting  
Mounting hole configuration to ISO 4401-03-02-0-05  
Subplates as per Technical Data Sheet RE 45052 (order separately)
- Dry servo motor, no contamination of solenoid gaps by pressure fluid
- Non-wearing piston return element
- Actuation:  
External trigger electronics in Eurocard format or in modular form (order separately), see page 6
- Valve is calibrated and tested
- Pressure chambers in the control bush have gap seals, no O-ring wear
- Filter for 1st stage freely accessible from the outside

## Ordering data and scope of delivery

<b>4WS2EM</b>	<b>6</b> $\frac{-2X}{/}$	<b>B</b>	<b>11</b>	<b>XN</b>	<b>ET</b>	<b>K17</b>	<b>V</b> $\frac{-102}{/}$
Electrically operated 2-stage servo valve of 4/3-way design with mechanical return for <b>external</b> trigger electronics Nominal size 6 = 6							
Unit series 20 to 29 = 2X (20 to 29: installation and connection dimensions unchanged)							
<b>Nominal flow</b> <sup>1)</sup> 2 l/min = 2 5 l/min = 5 10 l/min = 10 15 l/min = 15 20 l/min = 20 25 l/min = 25 See characteristic curves on page 7 (note tolerance zone of flow signal function)							
Valve for <b>external</b> trigger electronics Coil No. 11 (30 mA/85 Ω per coil) <sup>2)</sup> = 11							
						102 = Non-standard version number <sup>6)</sup> <b>Seal material</b> V = FKM seals suitable for mineral oil (HL, HLP) to DIN 51524 <b>Piston overlap</b> <sup>5)</sup> E = 0 ... 0,5 % negative D = 0 ... 0,5 % positive C = 3 ... 5 % positive K17 = <b>Electrical connection                  using connector</b> Order plug-in connector separately, see page 6 <b>Supply pressure range</b> <sup>4)</sup> 210 = 10 to 210 bar 315 = 10 to 315 bar ET = Internal control oil supply and discharge <sup>3)</sup>	
				XN = Valve in explosion-proof design For details, see information on explosion protection, page 6			

### Included in scope of delivery:

Valve operating instructions

#### 1) Nominal flow rate

The nominal flow rate is based on a 100 % setpoint signal at a valve pressure differential of 70 bar (35 bar per metering notch). The valve pressure differential should be regarded as a guide. The flow rate can be affected by other values. A possible nominal flow tolerance of  $\pm 10$  % (see flow signal function on page 7) must be taken into consideration.

#### 2) External trigger electronics

The control signal must be generated by a current regulated output stage. For trigger electronics (servo amplifiers), see page 6.

#### 3) Control oil

This valve is only supplied with internal pilot oil supply and discharge.

#### 4) Inlet pressure range

The system pressure should be kept as constant as possible. With regard to the dynamics, please bear in mind the frequency relationship within the permissible pressure range of 10 ... 210 bar or 10 ... 315 bar.

#### 5) Piston overlap

The piston overlap is stated in % of the control piston stroke.

#### 6) Non-standard version number "102"

When not actuated (power off), ducts P → A and B → T are open 10 % of the nominal volume.

## Symbol

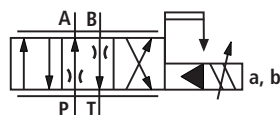

## Function, sectional diagram

### 4WS2EM 6-2X/...XN...-102

Valves of this type are electrically operated, 2-stage servo directional control valves with a mounting hole configuration to ISO 4401-03-02-0-05. They are predominantly employed for closed-loop position, draft, pressure and velocity control.

These valves consist of an electro-mechanical governor (torque motor) (1), a hydraulic amplifier (flapper jet principle) (2) and a control piston (3) in a sleeve (2nd stage), which is connected to the torque motor via a mechanical return.

An electric input signal at the coils (4) of the torque motor causes a permanent magnet to generate a force that acts on the armature (5) and, acting by means of a torque tube (6), this force generates a torque. This torque then moves the flapper plate (7) which is connected to the torque tube (6) by a rod out of its center position between the two control orifices (8), resulting in a pressure differential at the end faces of the control piston (3). This pressure differential causes the position of the piston to change, so that the pressure port is connected to one consumer port and, at the same time, the other consumer port is connected to the return port.

The control piston is connected to the flapper plate or the torque motor by a torsion spring (mechanical return) (9). The position of the piston continues to change until the return torque through the torsion spring and the electro-magnetic torque of the torque motor reach a state of equilibrium, and the pressure differential at the flapper jet system becomes zero.

In this way, the stroke of the control piston and thus the flow of the servo valve is closed loop controlled proportionately to the electrical input signal. At the same time, it should be noted that the flow is dependent on the drop in valve pressure.

#### External trigger electronics (order separately)

The valve is actuated by external trigger electronics (a servo amplifier), which amplifies an analog input signal (setpoint) so that the controlled current output signal is capable of driving the servo valve.

### Type 4WS2EM 6-2X/...XN...-102

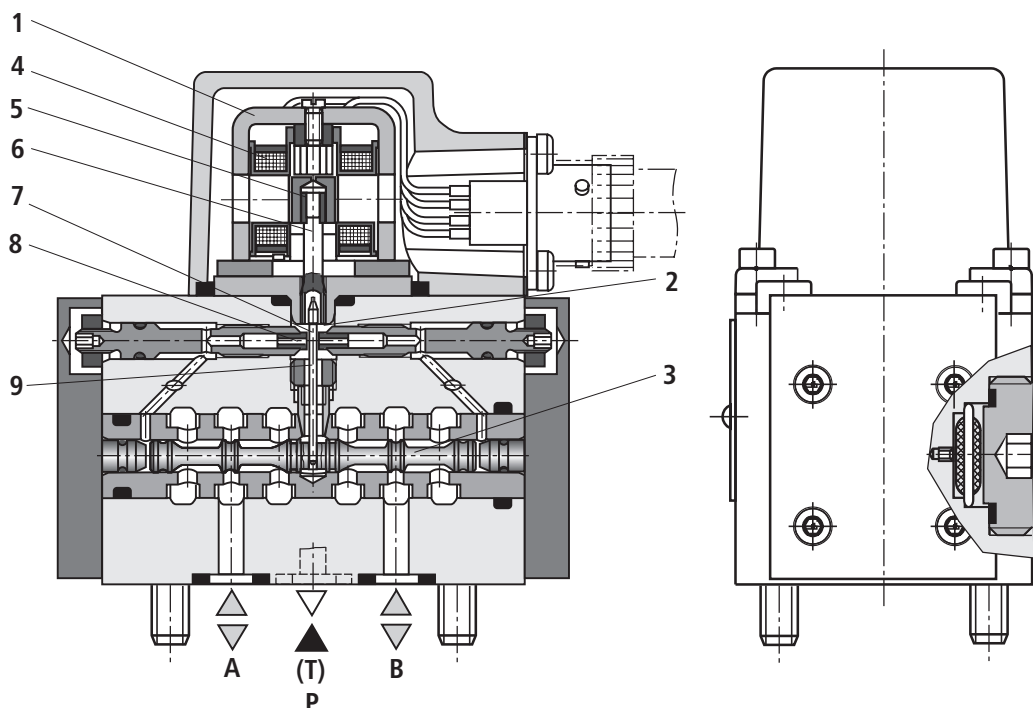

## Technical data

General		
Mounting hole configuration		ISO 4401-03-02-0-05
Installation position		Optional (provided that the pilot control is certain to receive sufficient pressure ( $\geq 10$ bar) when starting up the system!)
Surface protection	Valve body, cover, filter screw	Nitrocarburized
	Cap	Anodized
Storage temperature range	°C	-20 ... +80
Ambient temperature range	°C	-30 ... +70
Weight	kg	1.1
Hydraulic (measured with HLP 32, $\vartheta_{oil} = 40 \text{ °C} \pm 5 \text{ °C}$ )		
Operating pressure	Ports P, A, B	bar 10 ... 210 or 10 ... 315
Return pressure	Port T	bar Pressure peaks < 100, static < 10
Pressure fluid		Mineral oil (HL, HLP) to DIN 51524, ignition temperature > 150 °C
Pressure fluid temperature range	°C	-15 ... +80, preferably +40 ... +50
Viscosity range	mm <sup>2</sup> /s	15 ... 380, preferably 30 ... 45
Maximum permissible degree of contamination of pressure fluid Purity class to 4406 (c)		Class 18/16/13 <sup>1)</sup>
Zero flow $q_{V,L}$ <sup>2)</sup> with piston overlap E measured without dither signal	l/min	$\sqrt{p_p / 70 \text{ bar}} \cdot (0.4 \text{ l/min} + 0.02 \cdot q_{V,nom})$ <sup>3); 4)</sup>
Nominal flows $q_{V,nom}$ , Tolerance $\pm 10 \%$ at valve pressure differential $\Delta p = 70$ bar	l/min	2; 5; 10; 15; 20; 25
Max. possible control piston stroke based on mechanical end position (in case of fault) referred to nominal stroke	%	120 ... 170
Return system		Mechanical
Hysteresis (dither optimized)	%	$\leq 1.5$ at $p_p = 210 \text{ bar}$ <sup>4)</sup>
Range of inversion (dither optimized)	%	$\leq 0.2$ at $p_p = 210 \text{ bar}$ <sup>4)</sup>
Response sensitivity (dither optimized)	%	$\leq 0.2$ at $p_p = 210 \text{ bar}$ <sup>4)</sup>
Pressure gain with 1 % piston stroke variation (starting from hydraulic zero)	% of $p_p$ <sup>4)</sup>	$\geq 50$
Zero adjustment flow over entire working pressure range	%	$\leq 3$ , long-term $\leq 5$
Zero offset on variation of:		
Pressure fluid temperature	% / 20 °C	$\leq 1$
Ambient temperature	% / 20 °C	$\leq 1$
Working pressure 80 ... 120 % of $p_p$ <sup>4)</sup>	% / 100 bar	$\leq 2$
Return pressure 0 ... 10 % of $p_p$ <sup>4)</sup>	% / bar	$\leq 1$

<sup>1)</sup> The purity classes stated for the components must be complied with in hydraulic systems. Effective filtration prevents problems and also extends the service life of components. For a selection of filters, see Technical Data Sheets RE 50070, RE 50076 and RE 50081.

<sup>2)</sup>  $q_{V,L}$  = zero flow in l/min

<sup>3)</sup>  $q_{V,nom}$  = nominal flow in l/min

<sup>4)</sup>  $p_p$  = working pressure in bar

### Technical data

#### Electrical

Degree of protection to EN 60529	IP 65 with correctly mounted and locked plug-in connector		
Type of signal	Analog		
Nominal current per coil	mA	30	
Resistance per coil	$\Omega$	85	
Inductivity at 60 Hz and 100 % nominal current	Series connection	H	1.0
	Parallel connection	H	0.25
Necessary superimposed dither signal when actuating with non-Rexroth amplifiers: $f = 400$ Hz	Amplitude depending on hydraulic system: max. 3 % of nominal current		

#### Information on explosion protection

Range of application to Directive RL 94/9/EG	II 3 G; II 3 D	
Type of protection to EN 50014:1997+A1+A2 / EN 50021:1999	EEx nA IIT5	
Type of protection and temperature to EN 50281-1-1:1998+A1	IP 65, T100 °C	
Ambient temperature range	°C	-30 ... +70
Pressure fluid temperature range	°C	-15 ... +80
Max. permitted operating voltage of servo amplifier	V	32

#### External trigger electronics

Servo amplifier (order separately)	Eurocard format	Analog	Type VT-SR2-1X/.60 as per Technical Data Sheet RE 29980
	Modular design	Analog	Type VT 11021 as per Technical Data Sheet RE 29743

The valve coils should only be connected to this amplifier in parallel!

#### **⚠ WARNING – risk of explosion**

– The external servo amplifier must be operated outside the potentially explosive atmosphere!

#### Plug-in connector

Order separately under Material No. **R901043330**

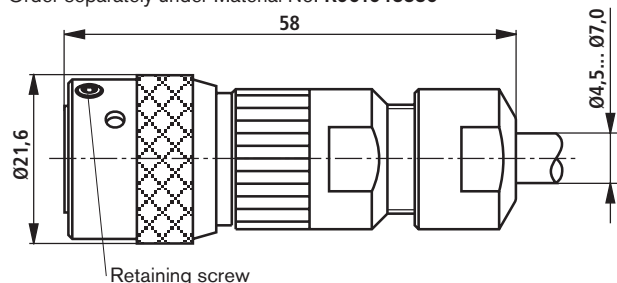

#### Connection:

Soldered contacts with conductor cross-section for wires 0.4 ... 0.75 mm<sup>2</sup>

#### Electrical connection (Example of parallel connection)

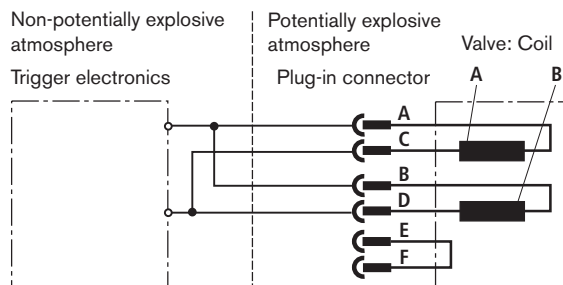

The coils are connected in parallel in the plug-in connector or to the amplifier (see figure).

In the case of a serial connection, connect contacts B and C.

The bridge E-F can be used for electrically recognizing that the plug is correctly connected or for detecting open circuits. Electrical actuation from A (+) to D (-) results in a flow direction of P → A and B → T. Reversing electrical actuation produces a flow direction of P → B and A → T.

**Characteristic curves** (measured with HLP 32,  $\vartheta_{oil} = 40\text{ °C} \pm 5\text{ °C}$ )

**Flow load function** (tolerance  $\pm 10\%$ ) with 100% setpoint signal

Note:

Observe flow values in the max. setpoint range  
(see tolerance zone of flow signal function)

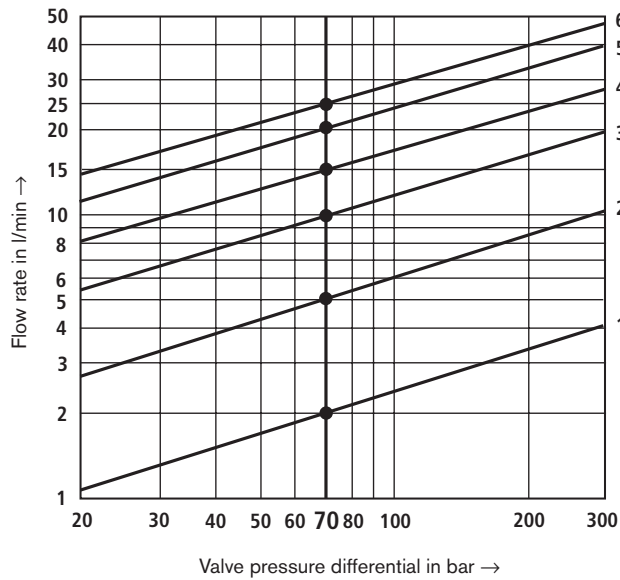

Order code	Nominal flow	Curve
2	2 l/min	1
5	5 l/min	2
10	10 l/min	3
15	15 l/min	4
20	20 l/min	5
25	25 l/min	6

$\Delta_p$  = valve pressure differential  
(inlet pressure  $p_p$   
minus load pressure  $p_L$  and  
minus return pressure  $p_T$ )

**Tolerance zone of flow signal function**

with constant valve pressure differential  $\Delta_p$

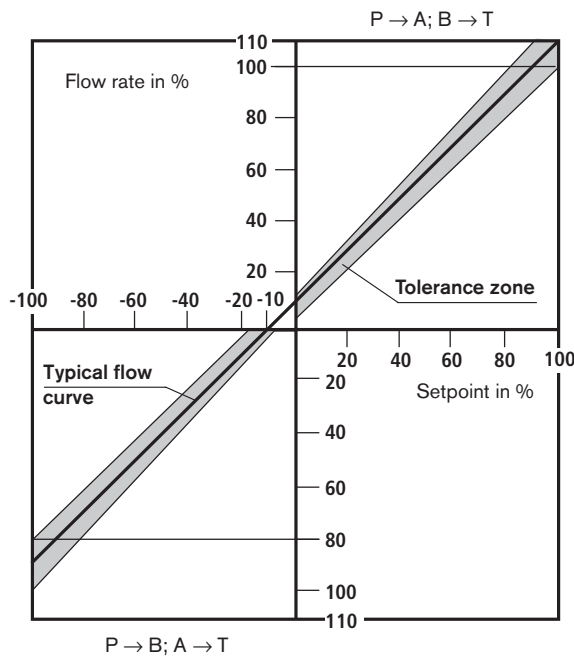

**Characteristic curves** (measured with HLP 32,  $\vartheta_{oil} = 40 \text{ }^\circ\text{C} \pm 5 \text{ }^\circ\text{C}$ )

Transient function with 315 bar pressure stage, step response without flow

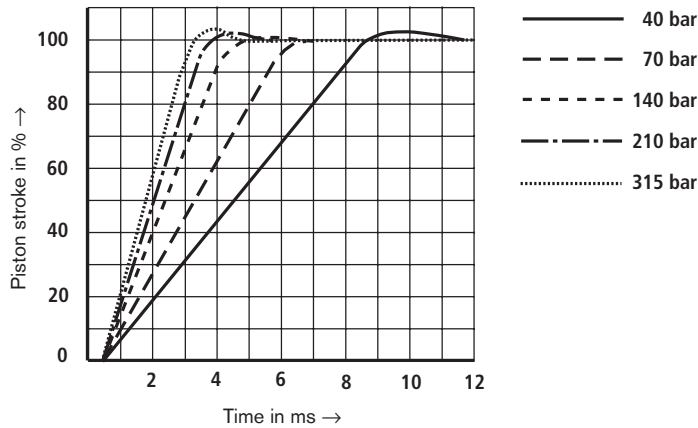

Frequency response with 315 bar pressure stage, stroke frequency response without flow

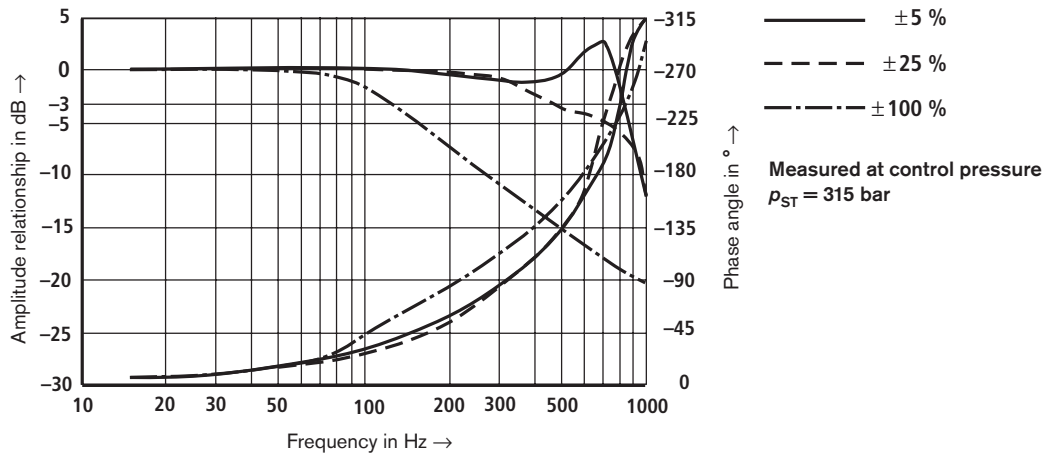

Relationship of frequency f at -90° to working pressure p and input amplitude

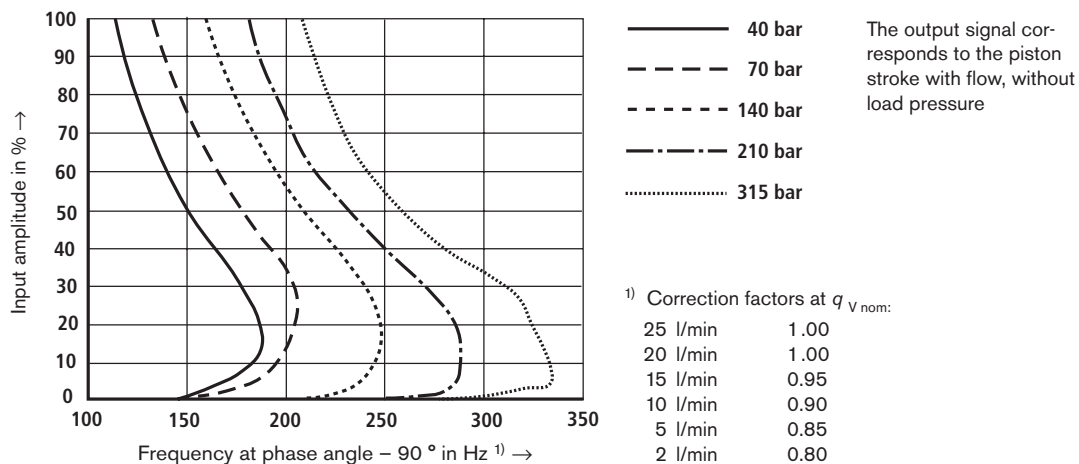

1) Correction factors at  $q_{Vnom}$ :

25 l/min	1.00
20 l/min	1.00
15 l/min	0.95
10 l/min	0.90
5 l/min	0.85
2 l/min	0.80

The output signal corresponds to the piston stroke with flow, without load pressure

**Unit dimensions** (Nominal dimensions in mm)

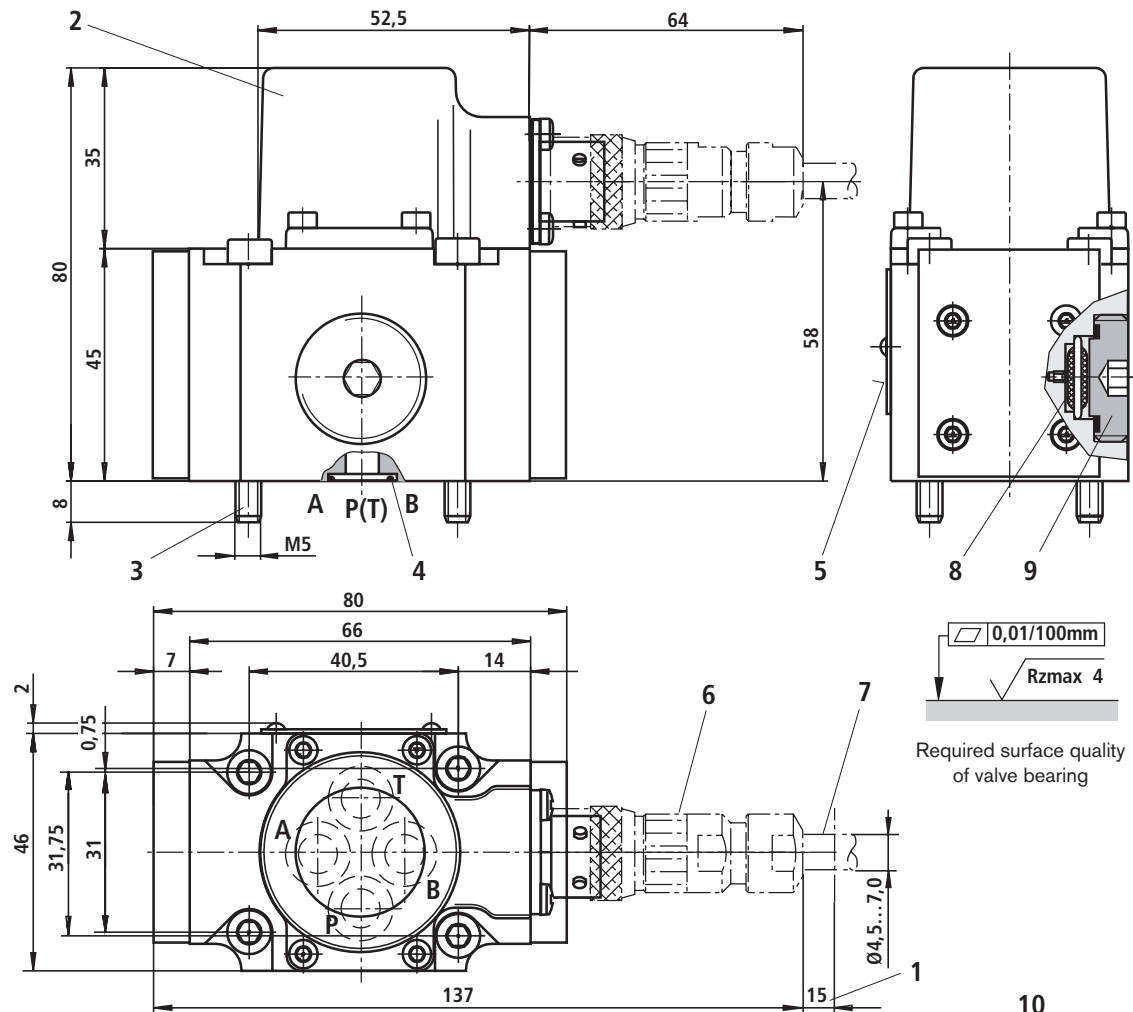

- 1 Required space for removing plug-in connector, allowing for bending radius of connecting lead
- 2 Cap
- 3 Valve fastening bolts  
In order to ensure a secure connection, use only the following valve fastening bolts:  
**4 cheese-head bolts**  
ISO 4762-M5x50-10.9-flZn-240h-L (coefficient of friction 0.09 - 0.14 to VDA 235-101)  
(included in scope of delivery)
- 4 Same seals for ports P, A, B and T
- 5 Nameplate
- 6 Plug-in connector  
(order separately, see page 6)

- 7 Connecting lead, see page 6 for further information
- 8 Filter
- 9 Screw plug
- 10 Machined valve contact surface  
Position of ports to ISO 4401-03-02-0-05  
Different from standard:  
- No locating pin (G)

**Subplates**  
G341/01 (G1/4)  
G342/01 (G3/8)  
G502/01 (G1/2)  
as per Technical Data Sheet RE 45052  
must be ordered separately

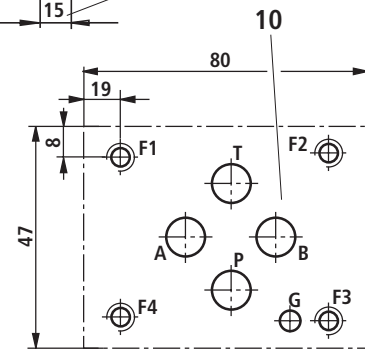

## Flushing plate with mounting hole configuration to ISO 4401-03-02-0-05 (Nominal dimensions in mm)

Symbol



### Ordering data and further information

- Material No.: **R900936049**
- Weight: 0.6 kg
- Same sealing rings for ports P, A, B and T
- Fastening bolts  
In order to ensure a secure connection, use only the following fastening bolts:  
**4 cheese-head bolts**  
**ISO 4762-M5x40-10.9-flZn-240h-L**  
(coefficient of friction **0.09 - 0.14** to VDA 235-101)  
(included in scope of delivery)

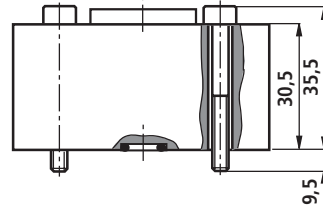

### Note

Before assembly, please read the notes in the Product-specific Instructions RE 29564-XN-102-B3, section 3.2.

Bosch Rexroth AG  
Hydraulics  
Zum Eisengießer 1  
97816 Lohr am Main, Germany  
Telefon +49 (0) 93 52 / 18-0  
Telefax +49 (0) 93 52 / 18-23 58  
documentation@boschrexroth.de  
www.boschrexroth.de

© This document, as well as the data, specifications and other information set forth in it, are the exclusive property of Bosch Rexroth AG. It may not be reproduced or given to third parties without its consent.  
The data specified above only serve to describe the product. No statements concerning a certain condition or suitability for a certain application can be derived from our information. The information given does not release the user from the obligation of own judgment and verification. It must be remembered that our products are subject to a natural process of wear and aging.

## Notes

---

Bosch Rexroth AG  
Hydraulics  
Zum Eisengießer 1  
97816 Lohr am Main, Germany  
Telefon +49 (0) 93 52 / 18-0  
Telefax +49 (0) 93 52 / 18-23 58  
documentation@boschrexroth.de  
www.boschrexroth.de

© This document, as well as the data, specifications and other information set forth in it, are the exclusive property of Bosch Rexroth AG. It may not be reproduced or given to third parties without its consent.  
The data specified above only serve to describe the product. No statements concerning a certain condition or suitability for a certain application can be derived from our information. The information given does not release the user from the obligation of own judgment and verification. It must be remembered that our products are subject to a natural process of wear and aging.

# HYQUIP

New Brunswick Street Horwich Bolton BL6 7JB UK  
Tel: +44 (0)1204 699959 Fax: +44 (0)1204 699542  
Email: [enquiries@hyquip.co.uk](mailto:enquiries@hyquip.co.uk) Web: [www.hyquip.co.uk](http://www.hyquip.co.uk)

## Notes

---

© This document, as well as the data, specifications and other information set forth in it, are the exclusive property of Bosch Rexroth AG. It may not be reproduced or given to third parties without its consent.  
The data specified above only serve to describe the product. No statements concerning a certain condition or suitability for a certain application can be derived from our information. The information given does not release the user from the obligation of own judgment and verification. It must be remembered that our products are subject to a natural process of wear and aging.

