

RE 28 164/02.03

Replaces: 11.02

Flow control valve Type Z2FRM 6

Nominal size 6

Series 2X

Maximum operating pressure 315 bar

Maximum flow 32 L/min

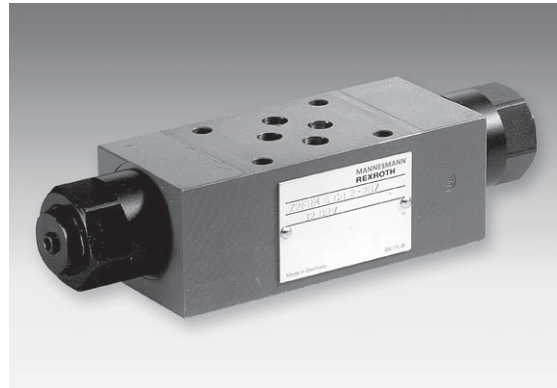

H 5379/96

Type Z2FRM 6 CB2-2X/32QRV

Overview of contents

Contents	Page
Features	1
Ordering details, preferred types	2
Symbols	2
Function, section	3
Technical data	4
Characteristic curves	4
Unit dimensions	5 to 7

Features

- Sandwich plate valve
- Porting pattern to DIN 24 340 Form A, **without** locating pin hole (standard)
- Porting pattern to ISO 4401 and CETOP–RP 121 H, **with** locating pin hole, (ordering code .../60 at the end of the valve type code)
- With 1 or 2 flow control cartridges
- Adjustment element with internal hexagon



© 2003
by Bosch Rexroth AG, Industrial Hydraulics

All rights reserved. No part of this document may be reproduced or stored, processed, duplicated or circulated using electronic systems, in any form or by any means, without the prior written authorisation of Bosch Rexroth AG. In the event of contravention of the above provisions, the contravening party is obliged to pay compensation.

Ordering details, preferred type

Z	2FRM	6		B	2-2X		R	V	*
Sandwich plate = Z	2-way flow control valve		Nominal size 6 = 6	Flow control function (meter-out control) in		Without closing of the pressure compensator = B		Adjustment element with internal hexagon = 2	Series 20 to 29 (20 to 29: unchanged installation and connection dimensions) = 2X
								Further details in clear text	
								No code = Without locating pin hole	/60 ² = With locating pin hole
								V = FKM seals (other seals on request)	⚠ Attention! The compatibility of the seals and pressure fluid has to be taken into account!
								R = With check valve	Flow 6Q = Up to 6.0 L/min 32Q = Up to 32.0 L/min

- ¹⁾ By rotating through the longitudinal axis a flow control function in port P is achieved (meter-in control), also see page 7.
- ²⁾ Locating pin 3 x 8 DIN EN ISO 8752, Material No. **R900005694** (separate order)

Preferred types (readily available)

Type	Material number
Z2FRM 6 AB2-2X/32QRV	R900549689
Z2FRM 6 BB2-2X/32QRV	R900549688
Z2FRM 6 CB2-2X/32QRV	R900549687
Z2FRM 6 CB2-2X/6QRV	R900910904

Further preferred types and standard units can be found in the EPS (Standard Price List).

Symbols (① = component side, ② = subplate side)

Type Z2FRM 6 A...

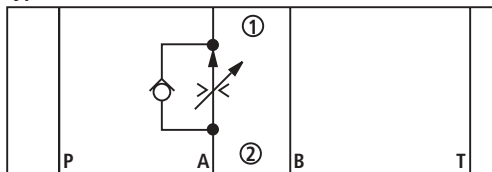

Type Z2FRM 6 B...

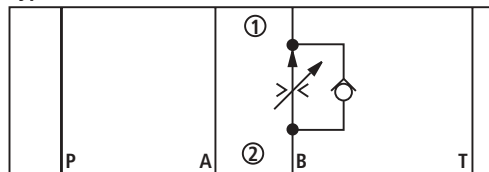

Type Z2FRM 6 C...

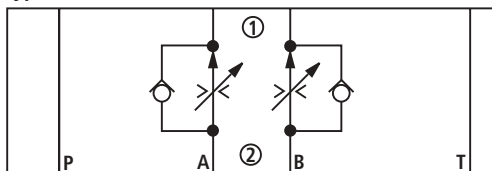

Type Z2FRM 6 T...

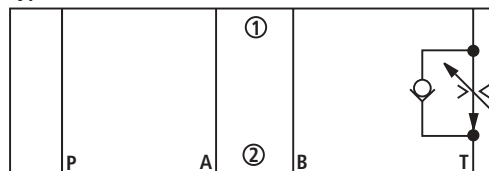

Function, section

The valve type Z2FRM is a 2-way flow control valve of sandwich plate design. It is used for maintaining a constant flow, independent of the pressure and temperature.

The valve basically consists of a housing (1) and one or two flow control cartridges.

The throttling of the flow from port A2/B2 to port A1/B1 occurs at the throttle area (3). The throttle cross-section is adjusted between the throttle (3) and the throttle bolt (4) by turning the adjustment element (2).

For holding the flow constant in port A1/B1, independent of the pressure, a pressure compensator (5) is fitted downstream of the throttle area (5).

The pressure compensator (5) is, via a compression spring (7), pressed against the plug (8) and so stays in the open position when there is no oil flow. If there is flow through the valve then the resulting pressure being applied in port A2/B2 acts as a force on the pressure compensator (5). This moves into the pressure compensation position until the forces are again balanced. If the pressure in port A2/B2 increases, then the pressure compensator (5) moves in the closing direction until the forces are balanced again. Due to the continuous compensation by the pressure compensator, a continuous flow is achieved.

Free return flow from port A1/B1 to port A2/B2 is via check valve (6).

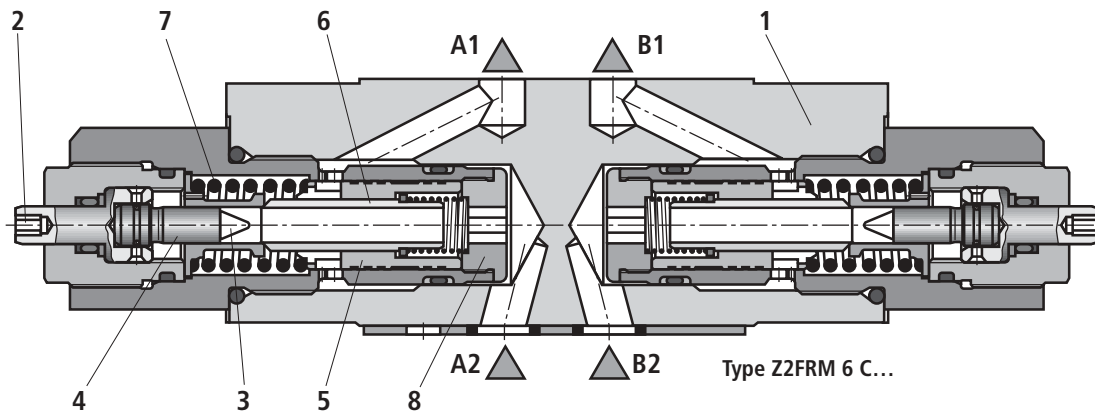

Technical data (for applications outside these parameters, please consult us!)

General

Connection type		– Porting pattern to DIN 24 340 Form A, without locating pin hole (standard) – Porting pattern to ISO 4401 and CETOP-RP121H, with locating pin hole, (ordering code .../60 at the end of the valve type code)
Ambient temperature range	°C	– 20 to + 50
Weight	kg	1.3 (flow control function in ports A, B or T)
		1.4 (flow control function in ports A and B)

Hydraulic

Nominal pressure	bar	315
Minimum pressure differential	At $q_{V \max}$	bar 18
	At $q_{V \min}$	bar 7
Pressure stable up to $\Delta p = 315$ bar	%	$\pm 3 (q_{V \max})$
Flow range	$q_{V \max}$	L/min 6; 32
	$q_{V \min}$	cm ³ /min 50; 250
Pressure fluid		Mineral oil (HL, HLP) to DIN 51 524; Fast bio-degradable pressure fluids to VDMA 24 568 (also see RE 90 221); HETG (rape seed oil); HEPG (polyglycols); HEES (synthetic ester); Other pressure fluids on request
Pressure fluid temperature range	°C	– 20 to +80
Viscosity range	mm ² /s	10 to 800
Cleanliness class to ISO code		Maximum permissible degree of contamination of the pressure fluid is to ISO 4406 (C) class 20/18/15 ¹⁾

¹⁾ The cleanliness class stated for the components must be adhered too in hydraulic systems. Effective filtration prevents faults from occurring and at the same time increases the component service life.

Characteristic curves (measured with HLP46, $\vartheta_{oil} = 40 \text{ °C} \pm 5 \text{ °C}$)

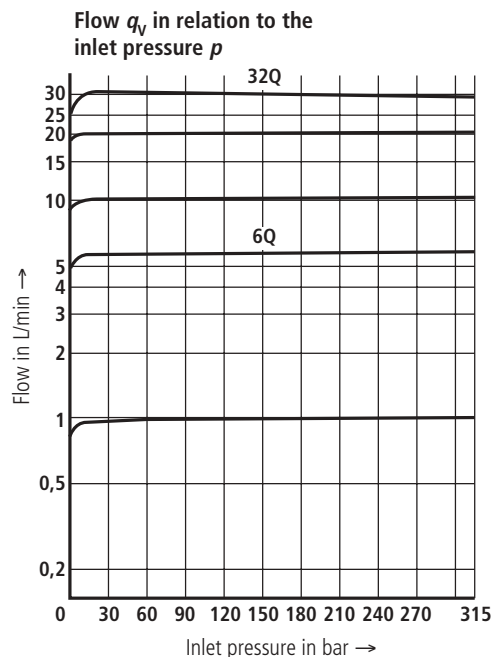
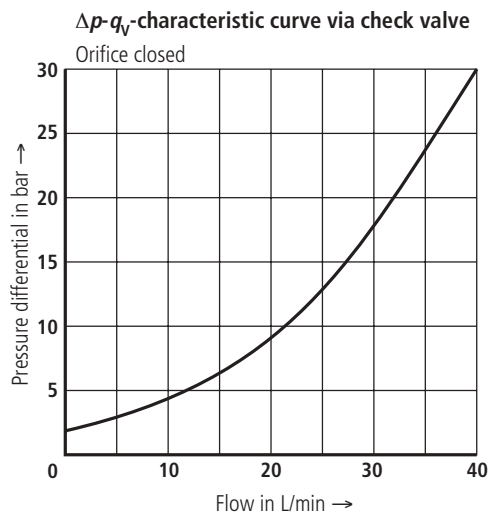

Unit dimensions: types Z2FRM 6 A... and Z2FRM 6 B... (dimensions in mm)

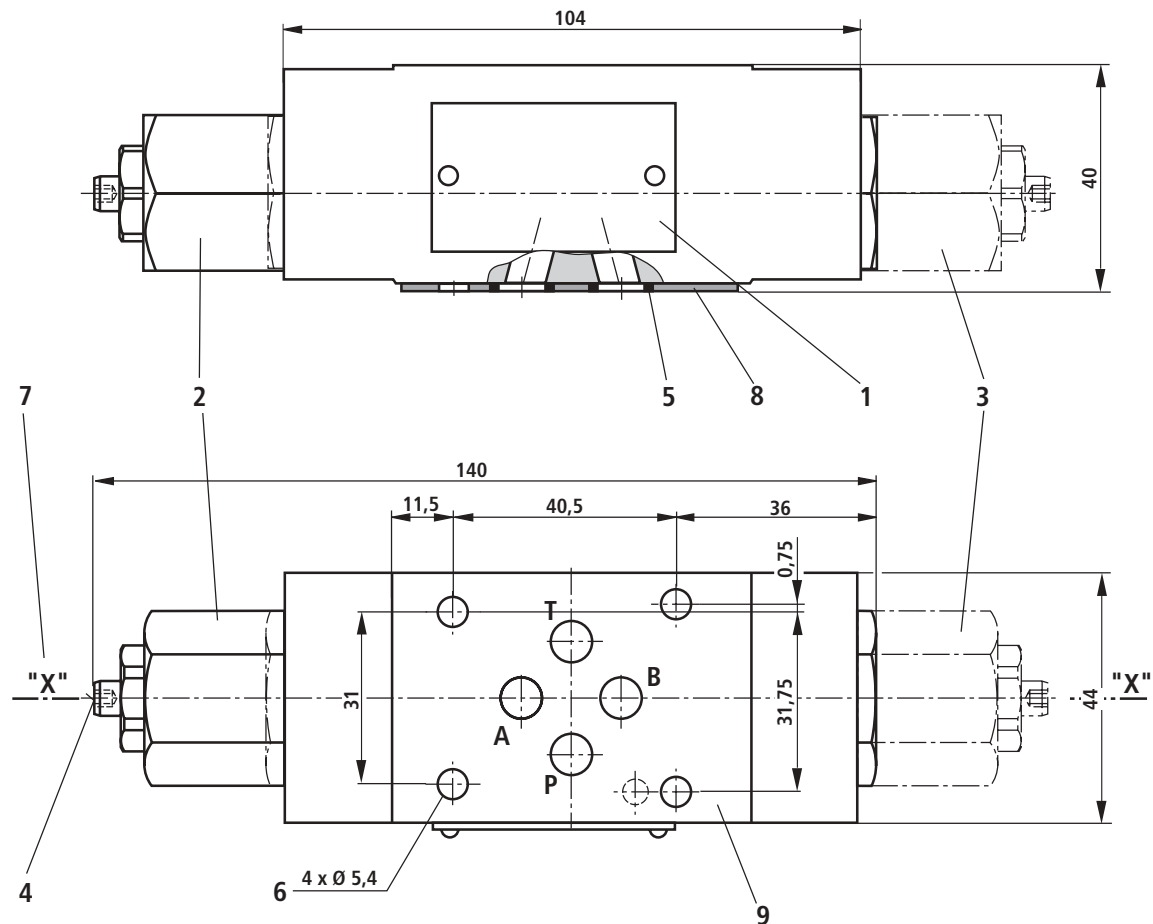

- 1 Name plate
- 2 Flow control cartridge with flow control in port A, hexagon 27A/F, $M_A = 50$ Nm
- 3 Flow control cartridge with flow control in port B, Hexagon 27A/F, $M_A = 50$ Nm
- 4 Adjustment element with internal hexagon 3A/F
- 5 Identical seal rings for ports A2, B2, P2, T2
- 6 Valve fixing holes
Valve fixing screws
M5 DIN 912-10.9, tightening torque $M_A = 8.9$ Nm, must be ordered separately.
- 7 To convert from meter-out into meter-in control, rotate the component about the "X"-"X" axis
- 8 Porting pattern to ISO 4401 and CETOP-RP121H with locating pin hole $\varnothing 3 \times 5$ mm deep, for a locating pin $\varnothing 3 \times 8$ DIN EN ISO 8752 Material No. **R900005694** (separate order)
- 9 Porting pattern to ISO 4401 and CETOP-RP121H with locating pin hole $\varnothing 4 \times 4$ mm

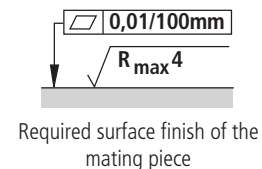

Unit dimensions: type Z2FRM 6 C... (dimensions in mm)

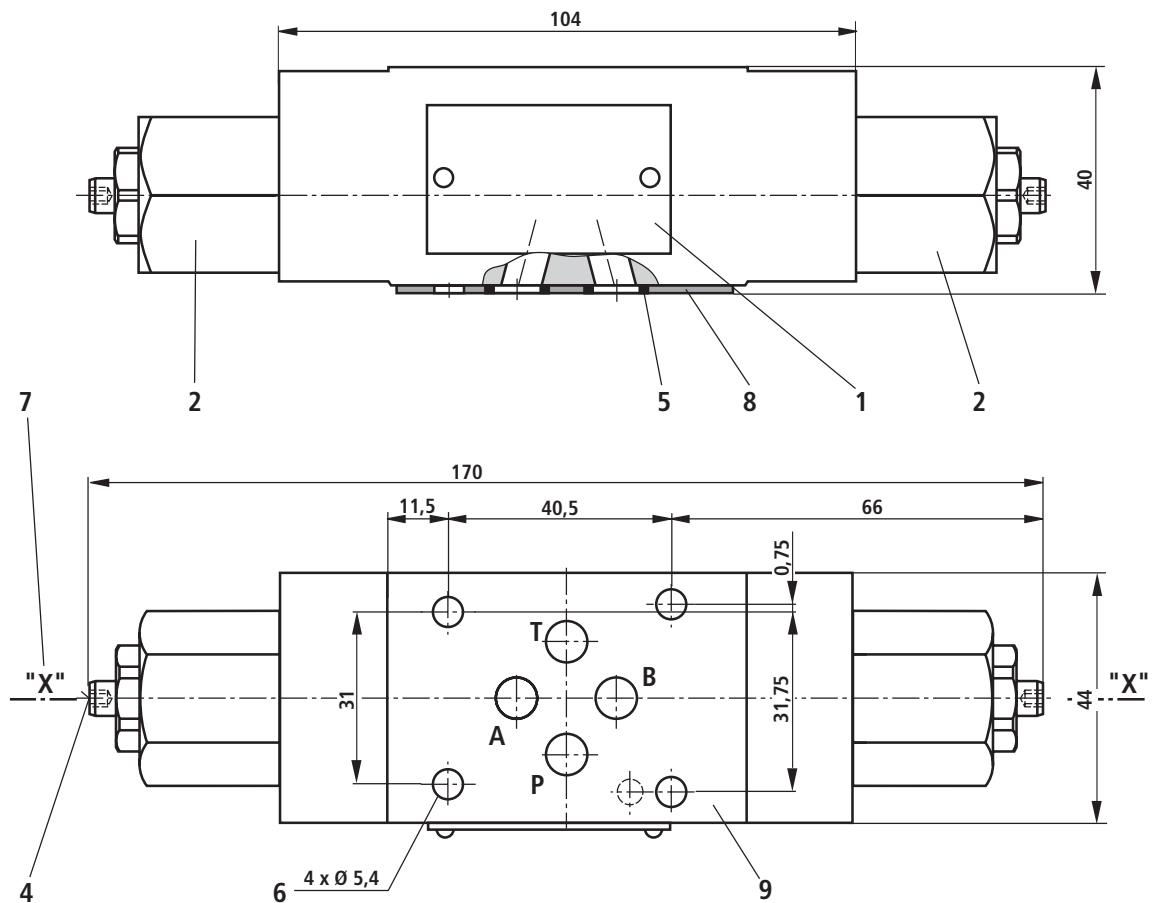

- 1 Name plate
- 2 Flow control cartridge, hexagon 27A/F, tightening torque $M_A = 50$ Nm
- 4 Adjustment element with internal hexagon 3A/F
- 5 Identical seal rings for ports A2, B2, P2, T2
- 6 Valve fixing holes

Valve fixing holes

M5 DIN 912-10.9, tightening torque $M_A = 8.9$ Nm, must be ordered separately.

- 7 To convert from meter-out into meter-in control, rotate the component about the "X"-"X" axis
- 8 Porting pattern to ISO 4401 and CETOP-RP121H with locating pin hole $\varnothing 3 \times 5$ mm deep, for a locating pin $\varnothing 3 \times 8$ DIN EN ISO 8752 Material No. **R900005694** (separate order)
- 9 Porting pattern to ISO 4401 and CETOP-RP121H with locating pin hole $\varnothing 4 \times 4$ mm

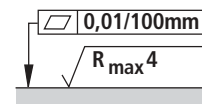

Required surface finish of the mating piece

Notes

The data specified above only serves to describe the product. No statements concerning a certain condition or suitability for a certain application can be derived from our information. The details stated do not release you from the responsibility for carrying out your own assessment and verification. It must be remembered that our products are subject to a natural process of wear and ageing.

