

Electronic signal transmitter

RE 29755/04.05
Replaces: 07.02

1/6

Type VT 10399

Series 5X
Three axes version



F 87013_d

Overview of contents

Contents

Features	
Ordering details	
Function	
Engineering guidelines	
Technical data	
Cable allocation	
Characteristic curves	
Zero position, directional and dead-man contact	
Circuit example	
Unit dimensions	

Features

Page	Contained within the VT 10399-5X electronic signal transmitter are the electronic and mechanical components which are used to convert the lever movement and the operating elements contained within the ball grip into a proportional electrical voltage. Due to the design of the lever joint, safe operation of only one axis is also possible.
1	
2	
2	
3	
3	Features:
4	– Sensitive control due to low operating forces
4	– Integrated evaluation electronics
5	– ± 15 V DC supply voltage
5	– Replacable gaiter
6	– Switched off if there is a cable break in the supply cables
	– Polarity protection
	Options:
	– Dead-man switch in the hand lever
	– The actuation pins of the Z axis are sealed (by means of a gaiter)
	– The ball grip can be deflected by $\pm 20^\circ$
	– Can be held in any position by means of a friction brake in the X and Y axes
	– Directional contacts for electrical monitoring of the hand lever movement

Ordering details

VT 10399		-5X/	-	-	-	*
Three axes signal transmitter						
Series 50 to 59		= 5X				
(50 to 59: unchanged technical data and connection allocation)						
Additional functions						
Friction brakes on X and Y axes		= BXY				
Friction brake X axis, spring return on Y axis		= BX0				
Friction brake Y axis, spring return on X axis		= B0Y				
Spring return on X and Y axes		= FXY				
Lever form and additional functions		Protection to EN 60529				
Ball grip, adjustable $\pm 20^\circ$		IP 53	= B			
Ball grip, fixed		IP 53	= C			
Ball grip, fixed with gaiter		IP 65	= D			
Ball grip only with direction contacts			= 80			
Ball grip with proportional output ± 10 V			= 90			
Ball grip with proportional output ± 10 V and two direction contacts (can also be used as zero position contacts)			= 9R			

Further details in clear text

Direction contact

R00 = No contact

RXY = Contact in the X and Y axes

T = ball grip **with** dead-man contact

A = ball grip **without** dead-man contact

Function

Mechanics

The simple robust mechanism consists of a control lever that is mounted in a swivel bearing. Two plastic track potentiometers are adjusted, these are orientated in relation to the associated axis. The actuation elements in the ball grip also adjusts the plastic track potentiometers, thereby sensitive control is also possible in the Z axis. On request the ball grip can be steplessly deflected (max. $\pm 20^\circ$) in relation to the control lever. Spring centring returns the control lever and ball grip into the neutral position when the lever is released. The mechanical components are protected by means of a gaiter.

Zero position, directional and dead-man contacts

In order to be able to electrically monitor the direction of lever movement and the zero position, a contact can be fitted per half axis. This contact closes when the lever is moved out of its neutral position within the range of $\pm 5\%$ to $\pm 10\%$ (referred to the output signal ± 10 V).

The transducer can also be fitted with a dead-man switch. This is operated by pressing the upper half of the hand lever (at right angles to the plane of installation).

When these functions are required, they are connected via a 2nd non-screened cable.

Electronics

The plastic track potentiometer is connected in series with an impedance converter, which ensures that the control curve remains within the specified limits, even with varying loading on the control output. The electronics also carry out other protective functions. Should a cable break in the ± 15 V supply lines occur, then the supply to the transducer is automatically switched off internally. The electrical connection is via multi-core screened cable.

The combination of plastic track potentiometer and impedance converter ensures that a long service life is achieved.

Engineering guidelines

Attention: If the transmitter is installed in a fully isolated manner, then the transmitter housing must be earthed by a separate cable!

Technical data (for applications outside these parameters, please consult us!)

Electronics	
Supply voltage	U ± 15 VDC (± 1 %) stabilised
Current consumption	I Approx. 50 mA
Control outputs	
– Output voltage	U Max. ± 10 V
– Output current	I Max. ± 5 mA
Switched contact	2 A, max. 30 VDC (ohmic load)
Fuse	I_s 2 A medium blowing characteristics
Mechanics	
Lever displacement angle	α Approx. 20° from the spring centred position to the end position (when operated in the X or Y directions)
Operating force	F Start value approx. 7 N Final value approx. 16 N
Protection to EN 60529	
– Above the mounting plane:	See ordering details
– Below the mounting plane:	IP 65
Cable length	l 600 mm
Permissible ambient temperature	ϑ –25 to +70 °C
Weight	m Approx. 2.0 kg

Cable allocation

Colour of the connecting cable (cable 1 – screened):

Supply lines:	Red	+15 V
	Black	M0 (measuring zero)
	Blue	-15 V
Signal lines:	White	M0 (measuring zero)
	Pink	X axis
	Green	Y axis
	Yellow	Z axis
Screen:	Yellow/Green	Housing transmitter
	Transparent	Screen

Colour of the connecting cable (cable 2 – non-screened):

Feed cable:	Blue	
Directional contacts:	Grey/Pink	X _A
	Red/Blue	X _B
	Yellow	Y _C
	Braun/Green	Y _D
	White/Yellow	Z _E
	Yellow/Brown	Z _F
Dead-man contact:	Grey	
Zero position contact:	Black	X axis
	Green	Y axis
	White/Green	Z axis

- Notes:**
- The cable screen is not connected internally!
 - If the transmitter is installed in a fully isolated manner, then the transmitter housing must be connected to earth!

Characteristic curves

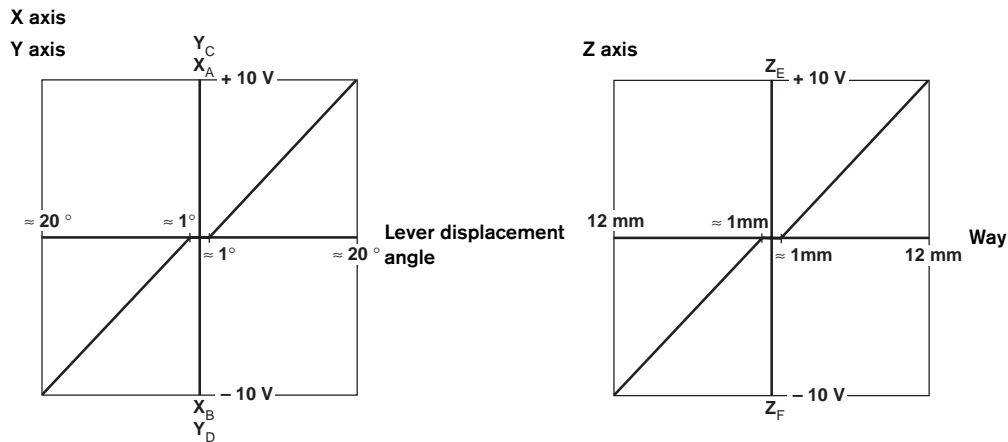

Zero position, directional and dead-man contacts

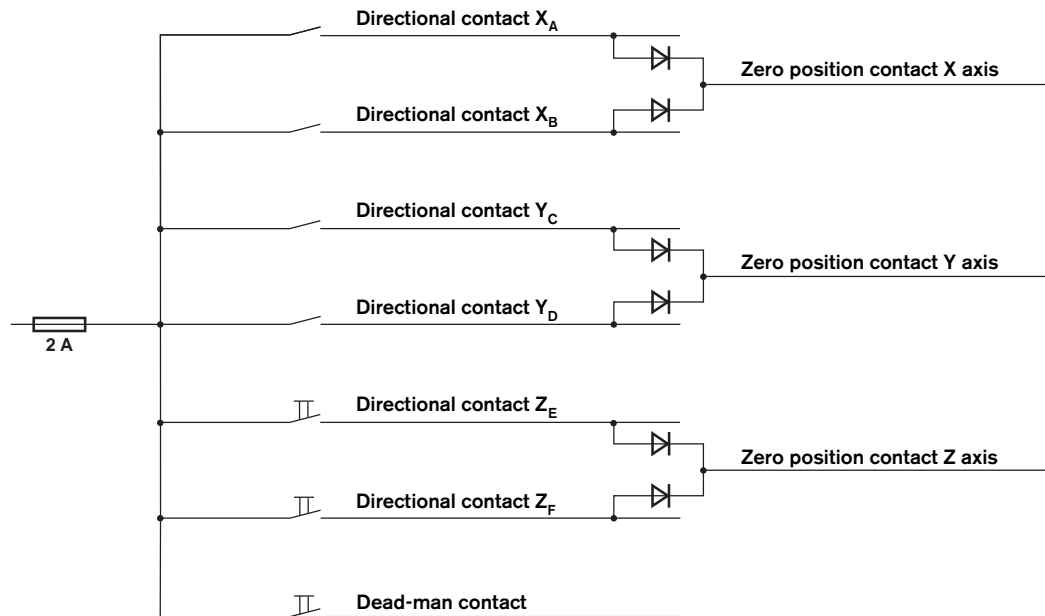

Circuit example

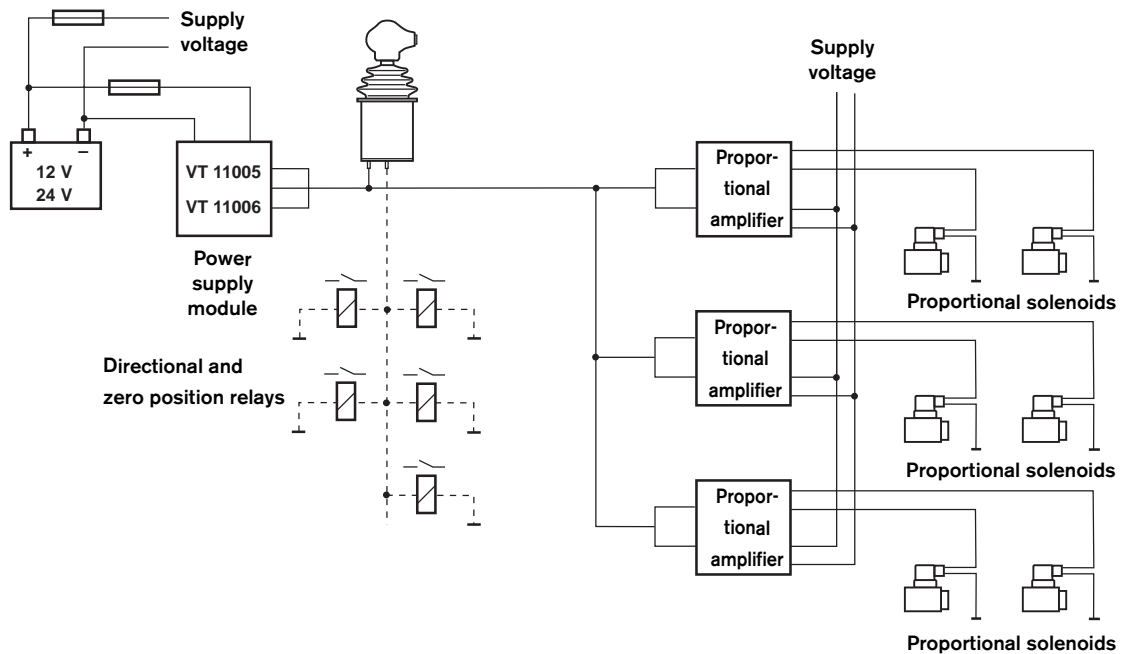

Unit dimensions (dimensions in mm)

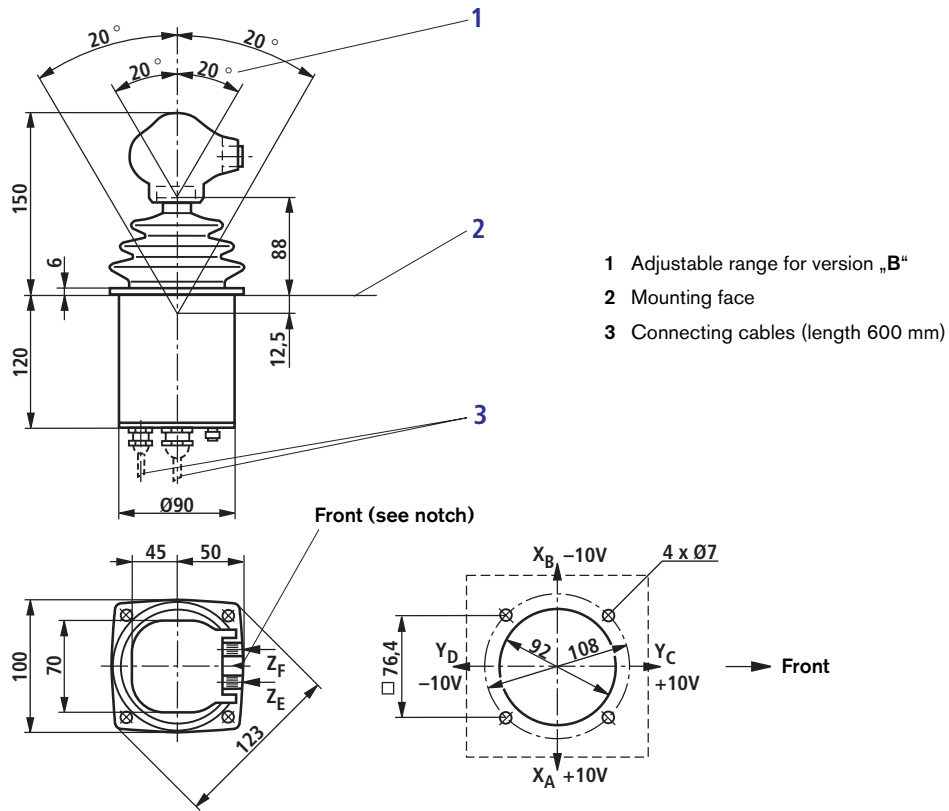

© This document, as well as the data, specifications and other information set forth in it, are the exclusive property of Bosch Rexroth AG. Without their consent it may not be reproduced or given to third parties.
The data specified above only serve to describe the product. No statements concerning a certain condition or suitability for a certain application can be derived from our information. The information given does not release the user from the obligation of own judgement and verification. It must be remembered that our products are subject to a natural process of wear and aging.