

Electronic signal transmitter

RE 29754/04.05
Replaces: 07.02

1/8

Type VT 10406

Series 3X
Two axes version



Overview of contents

Contents

Features	
Ordering details	
Function	
Engineering guidelines	
Technical data	
Cable allocation	
Characteristic curves	
Zero position, directional and dead-man contact	
Switch in the lever	
Circuit example	
Unit dimensions	

Features

Page	Contained within the VT 10406-3X electronic signal transmitter are the electronic and mechanical components which are used to convert the lever movement into two independent proportional signals. Due to the design of the lever joint safe operation of only one axis is also guaranteed.
1	
2	
2	
3	
3	– Sensitive control due to low operating forces
4	– Integrated evaluation electronics
4	– ± 15 V DC supply voltage
5	– Replacable gaiter
5	– Switched off if there is a cable break in the supply cables
6	– Polarity protection
7	

Options:

- Dead-man switch in the hand lever
- Additional controls are possible via various switches fitted into the hand lever
- Can be held in any position by means of friction brakes in the X and Y axes
- The zero point may be mechanically locked
- Directional contacts for electrical monitoring of the hand lever movement

Ordering details

VT 10406		3X	-	-	*
Two axes signal transmitter		Further details in clear text			
Series 30 to 39 (30 to 39: unchanged technical data and connection allocation)		= 3X	Direction contact		
Additional functions			R00 = No contact		
Friction brakes on X and Y axes		= BXY	RXY = Contact in X and Y axes		
Friction brakes on X axis, spring return on Y axis		= BX0	S = Standard		
Friction brakes on Y axis, spring return on X axis		= B0Y	K = Cross-form limiting gate		
Spring return on X and Y axes		= FXY			
Lever form	Additional functions	Protection to EN 60529			
Hand lever	None	IP 65	= 0		
Hand lever	Push button	IP 65	= 1		
Hand lever	Rocker switch	IP 65	= 2		
Hand lever	Pressure operated switch	IP 65	= 3		
Hand lever	Rocker switch with detent	IP 65	= 4		
Ball lever	None	IP 65	= 5		
Ball lever	With dead-man contact	IP 53	= 6		
Ball lever	With mech. pull detent	IP 65	= 7		

Function

Mechanics

The simple robust mechanism consists of a control lever mounted in a swivel bearing. Two plastic track potentiometers are adjusted, these are orientated in relation to the associated axis. When the control lever is released, springs return to its neutral position. The mechanical components are protected by means of a gaiter. The transmitter can be fitted with a friction brake on both axes which makes it possible to hold the control lever in any position. When the actuation of only one axis is permissible a cross-form of gate can be fitted. (simultaneous actuation of both axes is thereby not possible).

Zero position, directional and dead-man contacts

In order to be able to electrically monitor the direction of lever movement and the zero position, a contact can be fitted per half axis. This contact closes when the lever is moved out of its neutral position within the range of $\pm 5\%$ to $\pm 10\%$ (referred to the output signal of $\pm 10\text{ V}$).

The transducer can also be fitted with a dead-man switch. This is operated by pressing the upper half of the hand lever (at right angles to the plane of installation).

When these functions are required, they are connected via a 2nd non-screened cable.

Electronics

The plastic track potentiometer is connected in series with an impedance converter, which ensures that the control curve remains within the specified limits, even with varying loading on the control output. The electronics also carry out other protective functions. Should a cable break in the $\pm 15\text{V}$ supply lines occur, then the supply to the transducer is automatically switched off internally. The electrical connection is via a multi-core screened cable.

The combination of plastic track potentiometer and impedance converter ensures that a long service life is achieved.

Engineering guidelines

Attention: If the transmitter is installed in a fully isolated manner, then the transmitter housing must be earthed by a separate cable!

Technical data (for applications outside these parameters, please consult us!)

Elektronics		
Supply voltage	U	± 15 VDC (± 1 %) stabilised
Current consumption	I	Approx. 40 mA
Control outputs		
– Output voltage	U	Max. ± 10 V
– Output current	I	Max. ± 5 mA
Switched contact		2 A, max. 30 VDC (ohmic load)
Fuse	I_s	2 A, medium blowing characteristics
Mechanics		
Lever displacement angle	α	Approx. 20° from the spring centred position to the end position (when operated in the X or Y directions)
Operating force	F	Start value approx. 7 N Final value approx. 16 N
Protection to EN 60529		
– Above the mounting plane		See ordering details
– Below the mounting plane		IP 65
Cable length	l	600 mm
Permissible ambient temperature	ϑ	–25 to +70 °C
Weight	m	Approx. 1.8 kg

Cable allocation

Colour of the connecting cable (cable 1 – screened):

Supply lines:	Red	+15 V
	Black	M0 (measured zero)
	Blue	-15 V
Signal lines:	White	M0 (measured zero)
	Pink	X axis
	Green	Y axis
Screen:	Yellow/Green	Housing transmitter
	Transparent	Screen

- Notes:**
- The cable screen is not connected internally!
 - If the transmitter is installed in a fully isolated manner, then the transmitter housing must be connected to earth!

Colour of the connecting cable (cable 2 – non-screened):

Feed cable:	Blue
Directional contacts:	Grey/Pink X_A
	Red/Blue X_B
	Yellow Y_C
	Brown/Green Y_D
Dead-man contact:	Grey
Zero position contact:	Black X-Achse
	Green Y-Achse

Characteristic curves

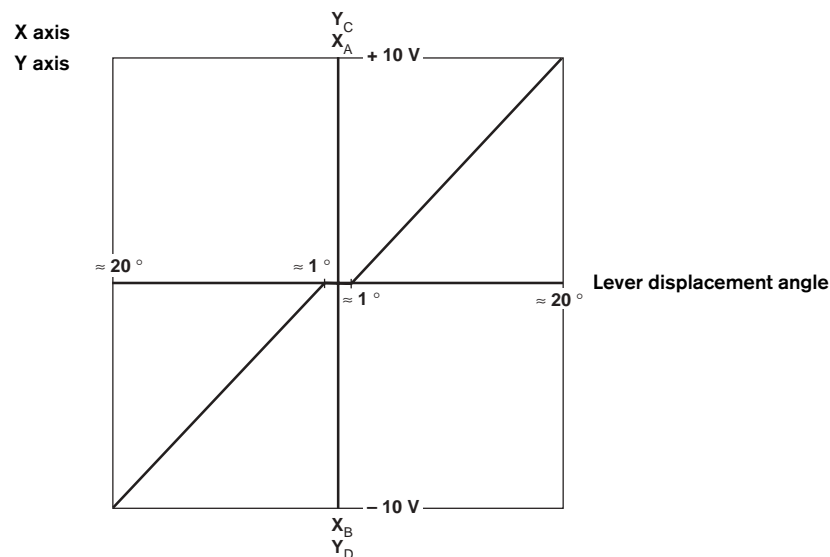

Zero position, directional and dead-man contacts

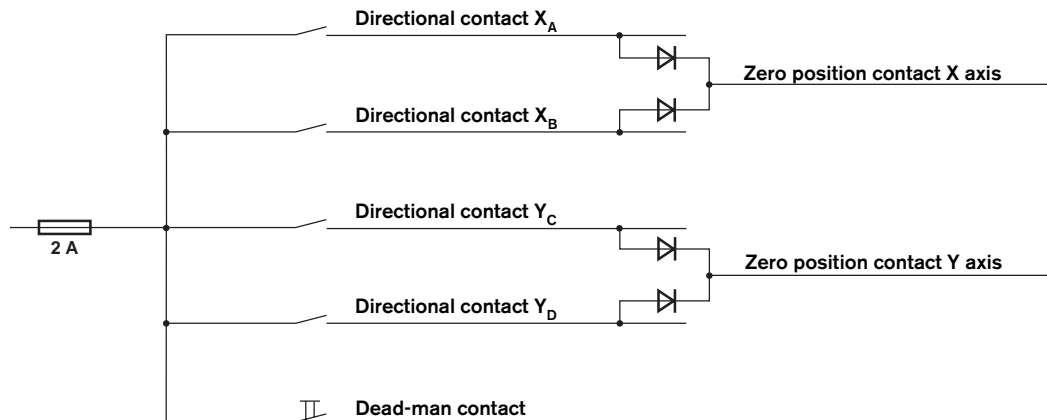

Switch in the lever

Pressure switch and push button:



Rocker switch and rocker switch with detent:

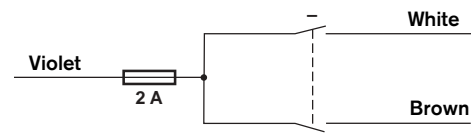

Colour of the connection cables (cable 2 – non-screened):

Feed cable:	Violet
Pressure operated switch and push button:	White
Rocker switch and rocker switch with detent:	Brown

Circuit example

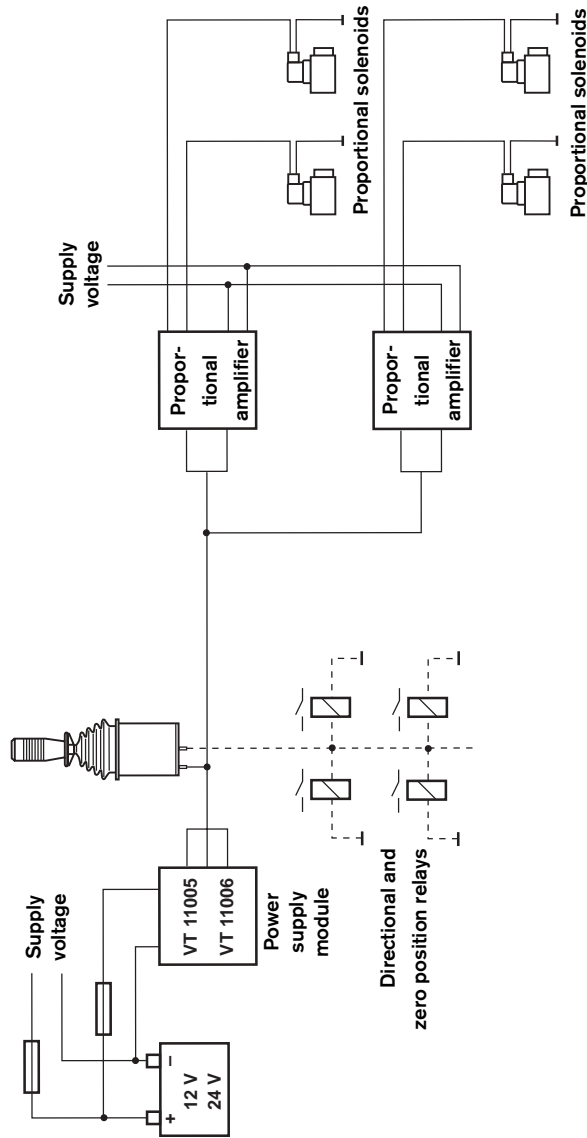

Unit dimensions (dimensions in mm)

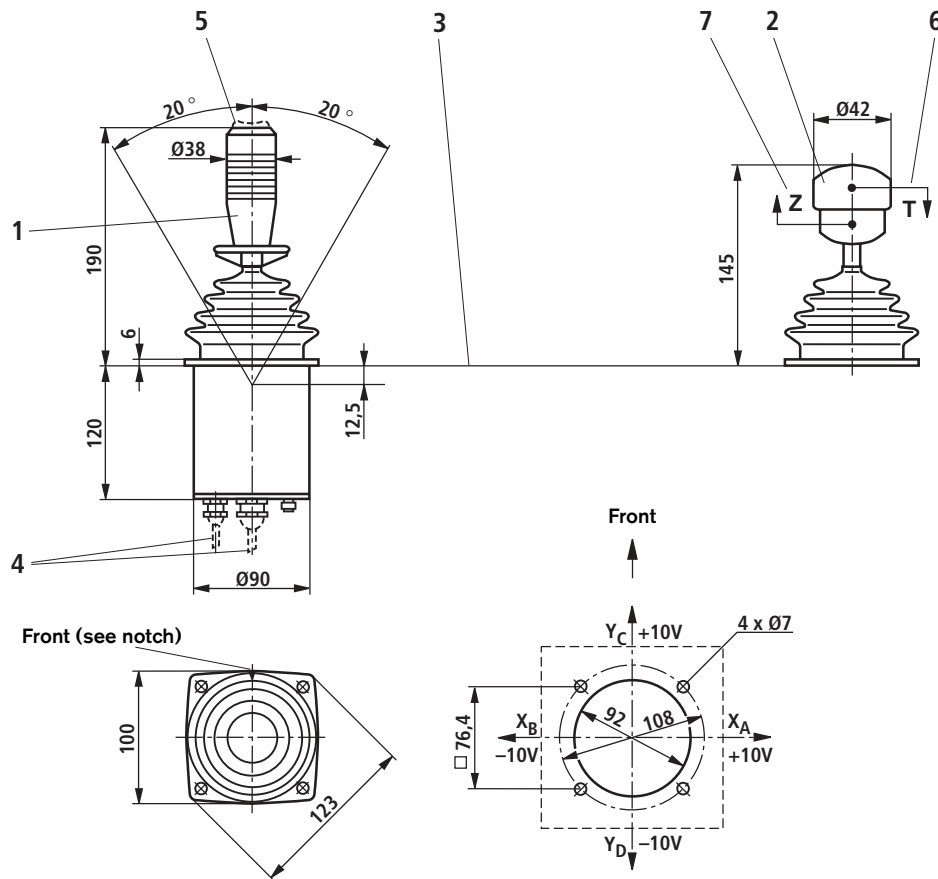

- 1 Hand lever
- 2 Ball lever
- 3 Mounting face
- 4 Connecting cables (length 600 mm)
- 5 Switch in lever (see ordering details)
- 6 Dead-man contact
- 7 Pull detent

Notes

© This document, as well as the data, specifications and other information set forth in it, are the exclusive property of Bosch Rexroth AG. Without their consent it may not be reproduced or given to third parties.

The data specified above only serve to describe the product. No statements concerning a certain condition or suitability for a certain application can be derived from our information. The information given does not release the user from the obligation of own judgement and verification. It must be remembered that our products are subject to a natural process of wear and aging.

