

## Electronic signal transmitter

**RE 29753-01/08.06** 1/4  
Replaces: RE 29753-D/02.00

Type VT 17328 (mod. VT 10468)

Series 3X  
Single axis version



F 87015\_d  
Basic Potentiometer Control VT 10468

### Overview of contents

#### Contents

Features	1
Ordering details	2
Function	2
Technical data	2
Cable allocation	3
Engineering guidelines	3
Zero position, directional and deadman contacts	3
Characteristic curves	3
Circuit example	4
Unit dimensions	4

### Features

<b>Page</b>	Contained within the VT 17328-3X electronic signal transmitter are the electronic and mechanical components which are used to convert the lever movement into a proportional electrical voltage.
1	
2	
2	
2	
3	– Basic Potentiometer Control: VT 10468-3X/...
3	– Change compared with base:
3	Output voltage is +10 V in both directions
3	– Sensitive control due to low operating forces
3	– Integrated evaluation electronics
4	– ±15 V DC supply voltage
4	– Replacable gaiter
	– Switched off if there is a cable break in the supply cables
	– Polarity protection
	<b>Options:</b>
	– Dead-man switch in the hand lever
	– Additional controls possible via various switches fitted into the hand lever
	– Can be held in any position by means of a friction brake
	– The zero point may be mechanically locked
	– Directional contacts for electrical monitoring of the hand lever movement

## Ordering details

<b>VT 17328</b>				<b>3X</b>	<b>F</b>	<b>0</b>	<b>RX</b>	<b>*</b>	
Single axis signal transmitter								Futher details in clear text	
Series 30 bis 39 (30 to 39: unchanged technical data and connection allocation)				= 3X					
<b>Additional functions</b>								<b>Direction contact</b>	
Spring return				= F					
				= 0					
<b>Lever form</b>		<b>Additional functions</b>		<b>Protection to EN 60529</b>					
Hand lever		None		IP 65					
				= 0					
						RX =			
						Contact in the X axis			

## Function

### Mechanics

The simple robust mechanism consists of a control lever mounted in a swivel bearing. By deflecting the lever, the setting of a plastic track potentiometer is changed. Dependent upon the model, the control lever is automatically spring returned to the neutral position or held in any position by a friction brake. A mechanical detent can also be fitted into the hand lever. The mechanism is protected by a rubber gaiter.

### Zero position, directional and dead-man contacts

In order to be able to electrically monitor the direction of lever movement and the zero position, a switch can be fitted per half axis. This switch closes when the lever is moved between  $\pm 5\%$  to  $\pm 10\%$  of the maximum travel (referred to the output signal).

### Electronics

The plastic track potentiometer is connected in series with an impedance converter, which ensures that the control curve remains within the specified limits, even with varying loading on the control output. The electronics also carry out other protective functions. Should a cable break in the  $\pm 15V$  lines occur, then the supply to the electronics is automatically switched off internally. The electrical connection is via multi-core screened cable.

The combination of plastic track potentiometer and impedance converter ensures that a long service life is achieved.

## Technical data (for applications outside these parameters, please consult us!)

<b>Electronics</b>	
Supply voltage	$U$ $\pm 15$ VDC ( $\pm 1\%$ ) stabilised
Current consumption	$I$ Approx. 30 mA
Control outputs	
– Output voltage	$U$ 0 to +10 V in both directions
– Output current	$I$ Max. 5 mA
Switched contacts	2 A, Max. 30 VDC (ohmic load)
Fuse	$I_s$ 2 A, medium blowing characteristics
<b>Mechanics</b>	
Lever displacement angle	$\alpha$ Approx. $20^\circ$ from the spring centre position to the end position (when operated in the X direction)
Operating force	$F$ Start value approx. 6 N Final value approx. 10 N
<b>Protection to EN 60529</b>	
– above the mounting plane:	IP 65
– below the mounting plane:	IP 65
Cable length	$l$ 600 mm
Permissible ambient temperature	$\vartheta$ $-25$ to $+70$ °C
Weight	$m$ Approx. 1.5 kg

### Cable allocation

Colour of the connecting cables (cable 1 – screened):

<b>Supply lines:</b>	Red	+15 V
	Black	M0 (measured zero)
	Blue	-15 V
<b>Signal lines:</b>	White	M0 (measured zero)
	Pink	X axis
<b>Screen:</b>	Yellow/green	Housing transmitter
	Transparent	Screen

- Notes:**
- The cable screen is not connected internally!
  - If the transmitter is installed in a fully isolated manner, then the transmitter housing must be connected to earth!

Colours of the connecting cables (cable 2 – non screened):

<b>Feed cable:</b>	Blue
<b>Directional contacts:</b>	Grey/Pink $X_A$
	Red/Blue $X_B$
<b>Zero position contact:</b>	Black X axis

### Characteristic curves

X axis

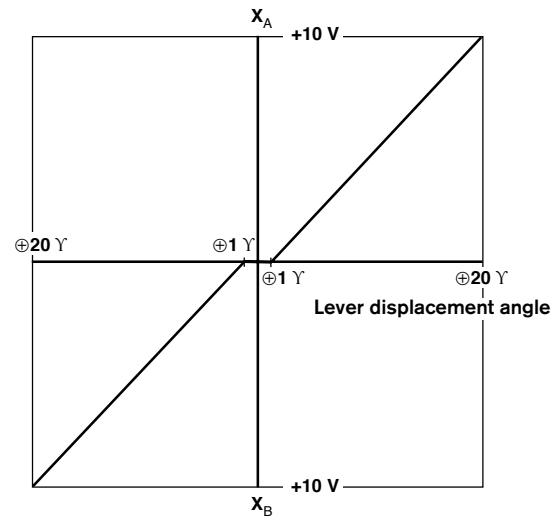

### Engineering guidelines

-  **Note!** If the transmitter is installed in a fully isolated manner, then the transmitter housing must be earthed by a separate cable!

### Zero position, directional and deadman contacts

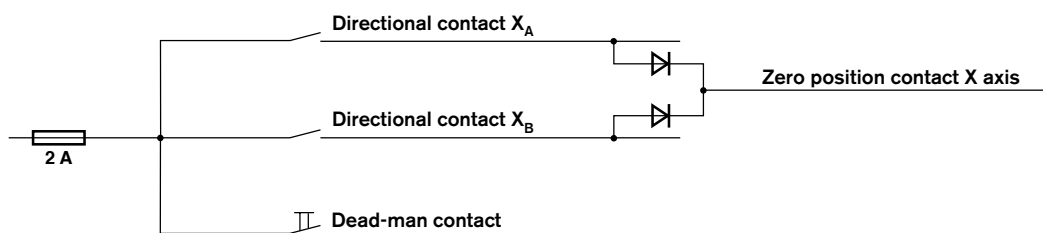

### Circuit example

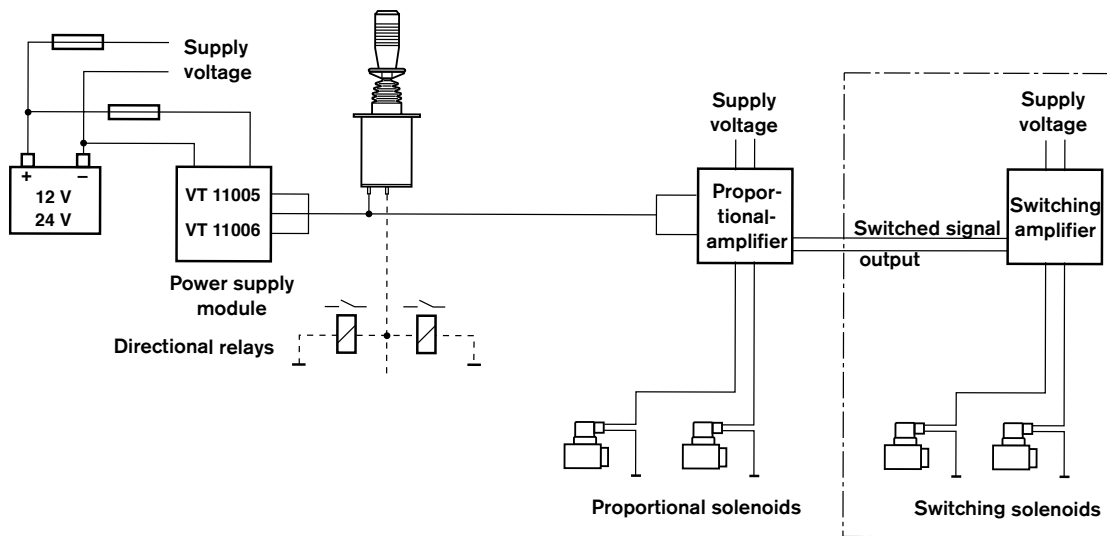

### Unit dimensions (dimensions in mm)

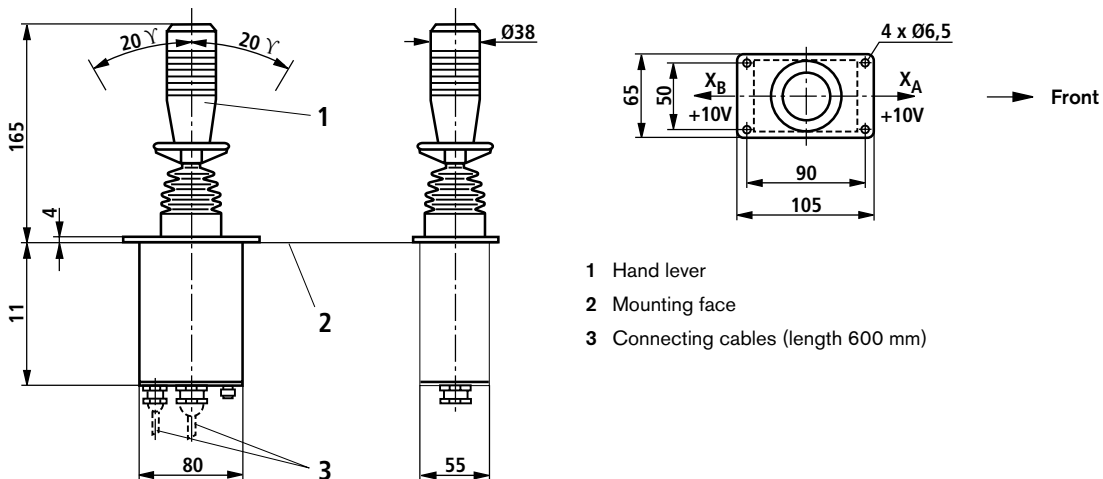

© This document, as well as the data, specifications and other information set forth in it, are the exclusive property of Bosch Rexroth AG. Without their consent it may not be reproduced or given to third parties.  
The data specified above only serve to describe the product. No statements concerning a certain condition or suitability for a certain application can be derived from our information. The information given does not release the user from the obligation of own judgement and verification. It must be remembered that our products are subject to a natural process of wear and aging.