



## Features

The digital axis control HNC100 is a programmable NC control for a closed-loop controlled axis. It meets the specific requirements for controlling hydraulic drives and, in addition, offers the possibility of controlling electric drives.

With regard to immunity to interference, mechanical resistance to vibration and shock and climate-proofness, the HNC100 is designed for use in harsh industrial environments. It conforms with EC Directives (CE mark).

### Fields of application:

- Machine tools, plastic processing machines, special machines
- Presses
- Transfer lines
- Rail-bound vehicles

### Programming:

- User programming with PC
- NC language with subroutine technique and conditional jumps
- Separate NC program for function sequences
- Local CAN bus for parameterizing several HNC100

### Operation:

- Comfortable administration of data on PC

### Process interfacing:

- 8, 16 or 24 digital inputs and outputs each
- Comfortable configuration of field bus interfacing with the help of the WIN-PED 5 Bus Manager

### Hydraulic axes:

- Measuring system:
  - Incremental or absolute (SSI)
  - Analog 0 to ±10 V and 4 to 20 mA
  - Reference voltage ±10 V
- Voltage or current control variable output
- Freely configurable controller variants
  - Position controller, pressure/force controller
  - Position-dependent braking
  - Alternating control (position/pressure)
  - Synchronization control for 2 axes

## Ordering code

<b>VT-HNC100</b>	<b>-2X/</b>	<b>-</b>	<b>-</b>	<b>0</b>	<b>*</b>	
Digital NC control HNC100						Further details in clear text
Variant for 1 hydraulic axis	= 1					0 = Without evaluation electronics
Variant for 2 hydraulic axes	= 2					0 = Without bus interface
Component series 20 to 29 (20 to 29: unchanged installation and connection dimensions)	= 2X					P = PROFIBUS DP <sup>1)</sup>
<b>Type of installation:</b>						C = CANopen
Housing for wall-mounting	= W					I = INTERBUS-S
Housing for rack installation	= M					
<b>For single-axis version:</b>						
8 digital inputs/outputs				= 08		
24 digital inputs/outputs				= 24		
<b>For 2-axis version:</b>						
16 digital inputs/outputs				= 16		

### Required accessories:

- Interface cable: Cable set VT15300-1X/03,0/, length 3 m, further lengths on request), Material no.: **R900842349**
- Optional USB adapter for the serial interface, VT-ZKO-USB/S-1-1X/V0/0, Material no.: **R901066684**

### Standard types

Type	Material number
VT-HNC100-1-2X/W-08-0-0	R900955334
VT-HNC100-1-2X/W-08-P-0	R900958999
VT-HNC100-1-2X/W-08-C-0	R900959000
VT-HNC100-2-2X/W-16-P-0	R900724314

<sup>1)</sup> Additional plug-in connector, type 6ES7972-0BA41-0XA0 for PROFIBUS DP is not included in the scope of supply and must be ordered separately! Material no.: **R900050152**

## Software project planning

### Configuration

The operation of the HNC100 is based on the creation of application-specific data sets. These data sets are generated on a PC and sent via the serial interface to the HNC100. The combination of the user program and data sets is called "project". The software configuration follows determined steps:

1. The tasks to be performed by the HNC100 are to be defined and in flowchart. The definition also refers to the meaning of inputs and outputs and the parameters used.
2. The functions of the sequence charts have to be implemented in the form of a sequence of NC commands.
3. The machine data (selection of transducers and controllers) and the parameters of the NC program have to be defined.
4. The data are sent to the HNC100.
5. Settings and program sequences are optimized on the machine.

### PC program "WIN-PED"

The PC program "WIN-PED" helps the user perform configuration tasks. It is used for programming, setting and diagnostics of the HNC100.

#### Scope of functions:

- Convenient dialog functions for online or offline setting of machine data

- NC Editor with integrated syntax check and program compiler
- Support for the definition of parameters used in the NC program
- Dialog window for online setting of parameter values
- Comprehensive options for displaying process data, digital inputs, outputs and flags
- Recording and graphical representation of up to four process variables via a selection of trigger options
- Dialog for the graphical definition of special functions (determination of function via polygon)

#### System requirements:

- IBM PC or compatible system
- Windows 2000 or Windows XP
- RAM (recommended: 256 MB)
- 60 MB free hard disk space

#### Note:

The PC program "WIN-PED 5" is **not** included in the scope of supply. It can be downloaded free of charge on the Internet!

Download on the Internet: [www.boschrexroth.de/hnc100](http://www.boschrexroth.de/hnc100)

Queries: [support.nc-systems@boschrexroth.de](mailto:support.nc-systems@boschrexroth.de)

## Overview of controller functions

### Position controller:

- PDT1-controller
- Linear gain characteristic curve
- Direction-dependent gain adjustment
- "Inflected" gain characteristic curve
- Gain alteration possible via the NC program
- Fine positioning
- Residual voltage principle
- Zero point error compensation
- Active damping
- Command value feedforward
- Limitation of control output via the NC program
- "Position-dependent braking"
- Intermediate electronics for use with commercial NC controls
- Synchronization control (only in conjunction with VT-HNC100-2...)

### Pressure/force controller:

- PIDT1-controller
- I-component can be cut in and out via window
- Differential pressure evaluation
- Own scan rate

### Velocity controller:

- PI-controller
- I-component can be cut in and out via window

### Monitoring functions:

- Dynamic following error monitoring
- Traversing range limits (electronic limit switches)
- Cable break monitoring for incremental and SSI encoders
- Cable break monitoring for sensors with 4 to 20 mA output

In the event of a fault, the output "no error" is reset and the controller deactivated!

## System overview

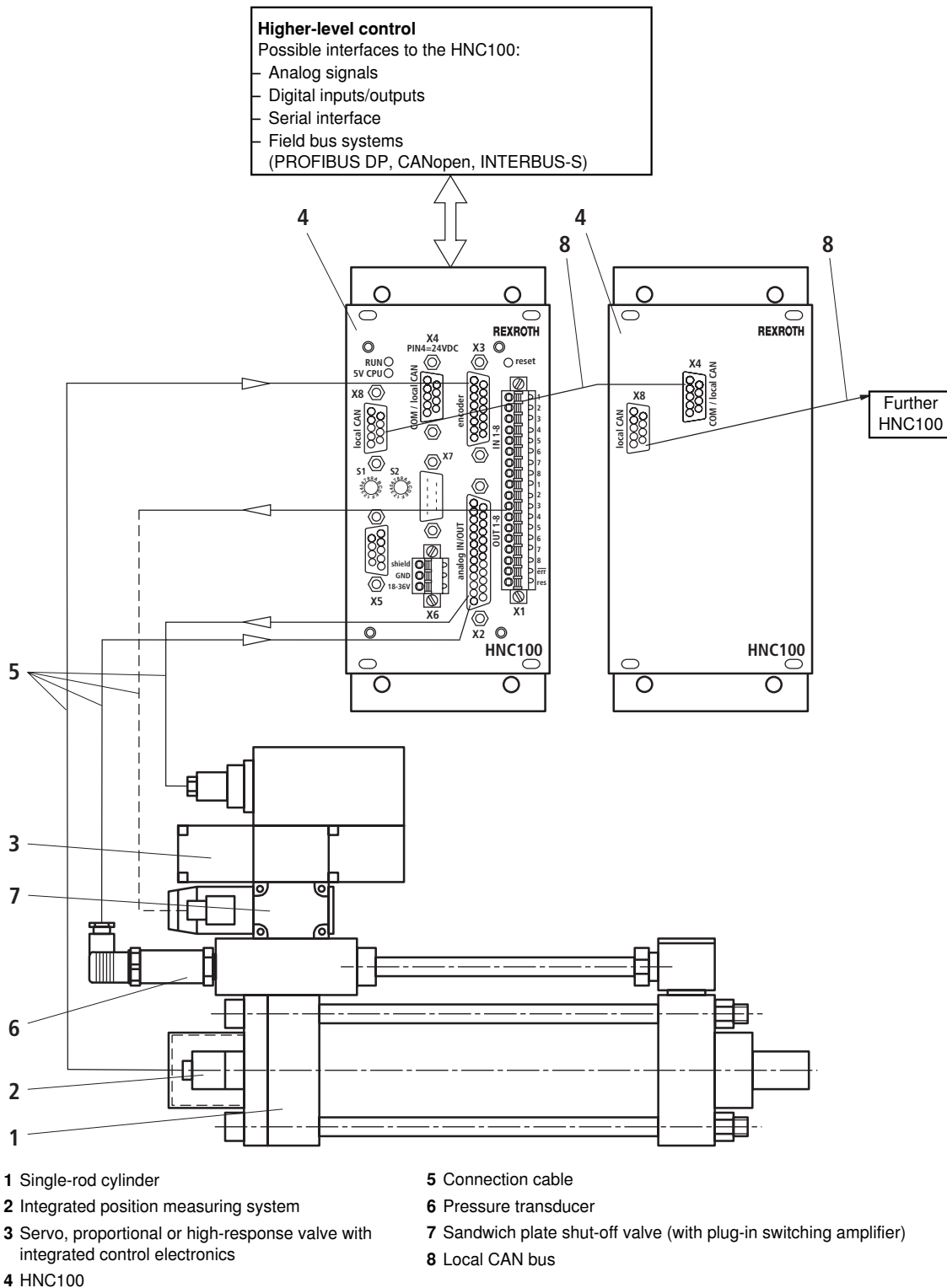

## Overview of NC commands for sequence control

For the programming of sequences, the following NC commands are available at the time of publication of this data sheet <sup>1)</sup>:

Definition part:	
/TRIG	Definition of a switching point
/E	Suppression of limit switches
/OVER	Override of velocity
/KD	Definition of a curve
/KT	Scan rate of a curve
/DFN	Normalization factor for curve polygon
/SE	Definition of system inputs
/SA	Definition of system outputs
NC Interpreter:	
KURVE	Start and stop of the curve function
K	Output of a voltage
KP	Alteration of controller gain
CLR	Resetting of output or flag
SET	Setting of output or flag
IF	Conditional branching
JMP	Jump to a flag (L000 to L1999)
JSR	Subroutine call
M17	End of subroutine
M02	End of main program
B	Variable for global variables
C	Variable for local variables
Lxxx	Jump flag
R	Value assignment for an R parameter
G64	Limitation of control output
BINE	Reading of binary-coded inputs
BINA	Output to binary-coded outputs
M22I	Setting of command value for position controller
G65/G66	Position monitoring in closed-loop pressure control "ON/OFF"
#define	Instruction
/EC	Definition of transducer monitoring
/ERROR	Definition of error response
/JMPSWITCH	Fast jump switch

Sequence control:	
G01	Point-to-point travel
G30	Point-to-point travel for oscillating movements
BREAK	Interruption of G01 or G30
STOP	Deceleration and completion, G01, G30
G53/G54	Zero point compensation "OFF/ON"
G70	Activation of closed-loop velocity control
G55	"Setting/reading" of values of zero point compensation
G63	Transition from closed-loop pressure/velocity control to closed-loop position control
M33/M34	Activation/deactivation" of position controller
M35/M36	Activation/deactivation" of synchronism
G26	Traversing to positive stop, closed-loop controlled
G25	Traversing to positive stop, open-loop controlled
G27, G28	Activation of pressure controller in dependence upon a position
G60	Activation of pressure controller
G61	Activation of pressure limitation
G62	Deactivation of pressure limitation
M22	Setting the actual and command value for the position controller
G04	Dwell time
M00	Waiting for input or flag
M90	Setting of output or flag
M91	Resetting of output or flag

<sup>1)</sup> This scope of functions is valid for the current software version. The efficiency of the system is continuously extended within the framework of software development.

**Technical data** (for applications outside these parameters, please consult us!)

Operating voltage	$U_B$	18 to 36 VDC
Power consumption	$P_{inter-nal}$	8 W (additional power for connected sensors/actuators)
Processor		16/32 Bit MC68376
Memory		Flash EPROM 1 MB; EEPROM 8 KB; RAM 256 KB (main memory)
Analog inputs <sup>1)</sup> :		
– Voltage inputs (differential inputs)		
• Number of channels		4
• Input voltage	$U_I$	+10 V to –10 V measurable (max. +15 V to –15 V)
• Input resistance	$R_I$	200 k $\Omega$ $\pm$ 2 %
• Resolution		5 mV
• Non-linearity		< 10 mV
• Calibration tolerance <sup>2)</sup>		max. 40 mV (with factory setting)
– Current inputs		
• Number of channels		4
• Input current	$I_I$	4 mA to 20 mA
• Input resistance	$R_I$	100 $\Omega$ $\pm$ 0.2 %
• Resistance between pin “I <sub>in</sub> 1 –” and “analog_GND”	$R$	0 to 500 $\Omega$
• Current loss	$I_L$	0.1 to 0.4 % (at 500 $\Omega$ between pin “I <sub>in</sub> 1 –” and “analog_GND”)
• Resolution		5 $\mu$ A
– Impedance inputs <sup>3)</sup>		
• Number of channels		4
• Input voltage	$U_{imp}$	–10 V to +10 V
• Input resistance	$R_{imp}$	> 10 M $\Omega$
• Resolution		5 mV
• Non-linearity		< 10 mV
• Calibration tolerance <sup>2)</sup>		max. 40 mV (with factory setting)
Analog outputs:		
– Voltage outputs <sup>4)</sup>		
• Number of channels		4
• Output voltage	$U_{nom}$	–10 V to +10 V (max. –10.7 V to +10.7 V)
• Output current	$I_{max}$	$\pm$ 10 mA
• Load	$R_{min}$	1 k $\Omega$
– Current outputs <sup>4)</sup>		
• Number of channels		2
• Output current	Normalized $I_{nom}$	4 mA to 20 mA
	Not normalized $I_{max}$	$\pm$ 23 mA
• Load	$R_{max}$	500 $\Omega$
– Residual ripple content		$\pm$ 60 mV (without noise)
– Resolution		1,25 mV
– Non-linearity		
• within the range of –9.5 V to +9.5 V		15 mV
• within the range of –10 V to –9.5 V and +9.5 V to +10 V		35 mV

<sup>1)</sup> Not all of the channels can be used simultaneously. The voltage inputs and the current inputs are provided with a common pin so that either the voltage input **or** the current input can be used at a time. The current can be looped through several current measuring devices. Otherwise, a jumper must be plugged from pin “I<sub>in</sub>” to pin “analog\_GND”.

<sup>2)</sup> If the factory settings are not sufficient, the measuring equipment can be calibrated on site according to the system requirements.

<sup>3)</sup> Due to the characteristics of these high-resistance inputs, **no internal protective circuits** with diodes or capacitors can be used. For this reason, when connecting analog signals to inputs U<sub>imp</sub> 1 to U<sub>imp</sub> 4, all required protective measures, EMC protection, signal filtration, must be connected **externally** in the incoming circuit.

<sup>4)</sup> Outputs “U<sub>out</sub> 1” and “I<sub>out</sub> 1” as well as “U<sub>out</sub> 2” and “I<sub>out</sub> 2” are electrically coupled. Normalization can be set to voltage or current by means of software.

**Technical data** (continued)

Serial interfaces	Standard Optional	RS232 (9,6 Kbaud) PROFIBUS DP (max. 12 Mbaud) CANopen, INTERBUS-S
Switching inputs	Number Logic level Connection	8, 16 or 24 log 0 (low) $\leq 5$ V; log 1 (high) $\geq 10$ V to $U_B$ ; $R_I = 3$ k $\Omega$ $\pm 10$ % Flexible conductor up to 1.5 mm <sup>2</sup>
Switching outputs	Number Logic level Connection	8, 16 or 24 log 0 (low) $\leq 2$ V; log 1 (high) $\leq U_B$ ; $I_{max} = 50$ mA Flexible conductor up to 1.5 mm <sup>2</sup>
Digital position transducers:		
– Incremental transducer (transducer with TTL output)		
• Input voltage	log 0 log 1	0 to 1 V 2.8 to 5.5 V
• Input current	log 0 log 1	–0.8 mA (at 0 V) 0.8 mA (at 5 V)
• Max. frequency referred to $U_a$ 1	$f_{max}$	250 kHz
– SSI transducer		
• Coding		Gray code
• Data width		Adjustable up to max. 28 bits
• Line receiver (TTL)		
Input voltage	log 0 log 1	0 to 1 V 2.8 to 5.5 V
Input current	log 0 log 1	–0.8 mA (at 0 V) 0.8 mA (at 5 V)
• Line driver		
Output voltage	log 0 log 1	0 to 0.5 V (at 120 $\Omega$ ) 2.5 to 5.5 V (at 120 $\Omega$ )
Voltage supply to position transducers by the HNC100	$U$	$U_B$ or +5 VDC $\pm 5$ %; max. 200 mA
Max. voltage for all input signals	$U_{max}$	$U_B - 1$ V (signals are not opto-decoupled)
Inductive position transducers:		
– Number		2
– Power supply	$U_{eff}$	2 V ( $I_{max} = 30$ mA / channel) Balanced to ground, short-circuit-proof, can be synchronized between 4.8 and 5.2 kHz, optional compensation capacitor 220 nF; amplitude stability $\leq 0.2$ % /10 K; carrier frequency 5 Hz $\pm 2$ %; inductive transducers in half- and full-bridge circuit and 3- and 4-conductor circuit; linearity error $< 0.1$ %
Reference voltage	$U_{ref}$	+10 V $\pm 25$ mV and –10 V $\pm 25$ mV (20 mA each)
Dimensions (W x H x D):		
– VT-HNC100-1-2X/-08-.-.		71 x 155 x 204 mm
– VT-HNC100-2-2X/-16-.-. and VT-HNC100-1-2X/-24-.-.		106.5 x 155 x 204 mm
Permissible operating temperature range	$\vartheta$	0 to 50 °C
Storage temperature range	$\vartheta$	–20 to +70 °C
Weight:		
– VT-HNC100-1-2X/-08-.-.	$m$	1.0 kg
– VT-HNC100-2-2X/-16-.-. and VT-HNC100-1-2X/-24-.-.	$m$	1.2 kg

 **Note!**

For details regarding **environment simulation testing** in the fields of EMC (electromagnetic compatibility), climate and

mechanical stress, see RE 30131-U (declaration on environmental compatibility).

**Connector pinout VT-HNC100-1-2X/-.08...** (single-axis variant)

X8: Local CAN	
Pin 1	CAN_GND
2	res
3	res
4	res
5	res
6	res
7	res
8	CAN_H
9	CAN_L

X4: COM / local CAN	
Pin 1	CAN_GND
2	TxD
3	CTS
4	24 VN
5	0 VN
6	RxD
7	RTS
8	CAN_H
9	CAN_L

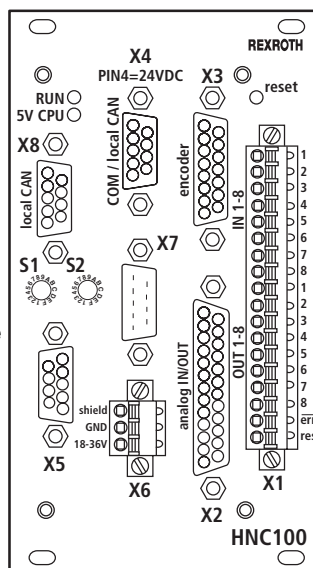

X3: Encoder		
Pin	incremental	SSI
1	/Ua 2	
2		Clocking
3	Ua 0	
4	/Ua 0	
5	Ua 1	Data
6	/Ua 1	/Data
7		/Clocking
8	Ua 2	
9	res	
10	0 VN	
11	res	
12	5 VTTL (max. 150 mA)	
13	res	
14	24 VN (max. 200 mA)	
15	res	

**S1, S2:**  
Address,  
baud rate  
CAN

**Note!**

The pins identified with "res" are reserved and must not be connected.

X5: Communication with higher-level control		
Pin	PROFIBUS DP	INTERBUS-S (OUT)
1	n.c.	DO 2
2	n.c.	DI 2
3	RxD/TxD-P	GND 2
4	CNTR-P	n.c.
5	DGND	U <sub>dd</sub>
6	VP	/DO 2
7	n.c.	/DI 2
8	RxD/TxD-N	n.c.
9	n.c.	BCI

X6: Power supply	
Pin 1	Shield
2	GND
3	18 - 36 VDC

X2: Analog IN / OUT		
Pin 1	U <sub>in</sub> 1 +	I <sub>in</sub> 1 -
2	U <sub>in</sub> 1 -	
3	U <sub>in</sub> 2 +	I <sub>in</sub> 2 -
4	U <sub>in</sub> 2 -	
5	U <sub>in</sub> 3 +	I <sub>in</sub> 3 -
6	U <sub>in</sub> 3 -	
7	U <sub>in</sub> 4 +	I <sub>in</sub> 4 -
8	U <sub>in</sub> 4 -	
9	I <sub>out</sub> 2	
10	U <sub>out</sub> 2	
11	analog_GND	
12	U <sub>ref</sub> = + 10 V	
13	U <sub>ref</sub> = - 10 V	
14	I <sub>out</sub> 1	
15	U <sub>out</sub> 1	
16	U <sub>out</sub> 3	
17	U <sub>out</sub> 4	
18		I <sub>in</sub> 1 +
19		I <sub>in</sub> 2 +
20		I <sub>in</sub> 3 +
21		I <sub>in</sub> 4 +
22	U <sub>imp</sub> 1	
23	U <sub>imp</sub> 2	
24	U <sub>imp</sub> 3	
25	U <sub>imp</sub> 4	

X1: Digital I/O	
Pin 1	IN1
2	IN2
3	IN3
4	IN4
5	IN5
6	IN6
7	IN7
8	IN8
9	OUT1
10	OUT2
11	OUT3
12	OUT4
13	OUT5
14	OUT6
15	OUT7
16	OUT8
17	/error
18	res

X7: Communication with higher-level control			
Pin	CANopen	inductive	INTERBUS-S (IN)
1	n.c.	Supply 1 +	DO1
2	CAN_L	Supply 1 -	DI1
3	CAN_GND	Signal 1 +	GND1
4	n.c.	Signal 1 -	n.c.
5	n.c.	Supply 2 +	n.c.
6	n.c.	Supply 2 -	/DO1
7	CAN_H	Signal 2 +	/DI1
8	n.c.	Signal 2 -	n.c.
9	n.c.	Sync IN/OUT	n.c.

**Connector pinout VT-HNC100-2-2X/-16... (2-axis variant)**

**Note!**

The pins identified with "res" are reserved and must not be connected.

X8: Local CAN		
Pin	1	CAN_GND
	2	res
	3	res
	4	res
	5	res
	6	res
	7	res
	8	CAN_H
	9	CAN_L

X4: COM / local CAN		
Pin	1	CAN_GND
	2	TxD
	3	CTS
	4	24 VN
	5	0 VN
	6	RxD
	7	RTS
	8	CAN_H
	9	CAN_L

X1.1 and X1.2: Digital IN/OUT		
Pin	X1.1	X1.2
1	IN1	IN9
2	IN2	IN10
3	IN3	IN11
4	IN4	IN12
5	IN5	IN13
6	IN6	IN14
7	IN7	IN15
8	IN8	IN16
9	OUT1	OUT9
10	OUT2	OUT10
11	OUT3	OUT11
12	OUT4	OUT12
13	OUT5	OUT13
14	OUT6	OUT14
15	OUT7	OUT15
16	OUT8	OUT16
17	/error	res
18	res	res

X3.1: Encoder 1		
Pin	Incremen- tal	SSI
1	/Ua 2	
2		Cllocking
3	Ua 0	
4	/Ua 0	
5	Ua 1	Data
6	/Ua 1	/Data
7		/Cllocking
8	Ua 2	
9	res	
10	0 VN	
11	res	
12	5 VTTL (max. 150 mA)	
13	res	
14	24 VN (max. 200 mA)	
15	res	

X3.2: Encoder 2		
Pin	Incremen- tal	SSI
1	/Ub 2	
2		Cllocking
3	Ub 0	
4	/Ub 0	
5	Ub 1	Dats
6	/Ub 1	/Dats
7		/Cllocking
8	Ub 2	
9	res	
10	0 VN	
11	res	
12	5 VTTL (max. 150 mA)	
13	res	
14	24 VN (max. 200 mA)	
15	res	

X6: Voltage supply		
Pin	1	Shield
	2	GND
	3	18 - 36 VDC

S1, S2:  
Address,  
baud rate  
CAN

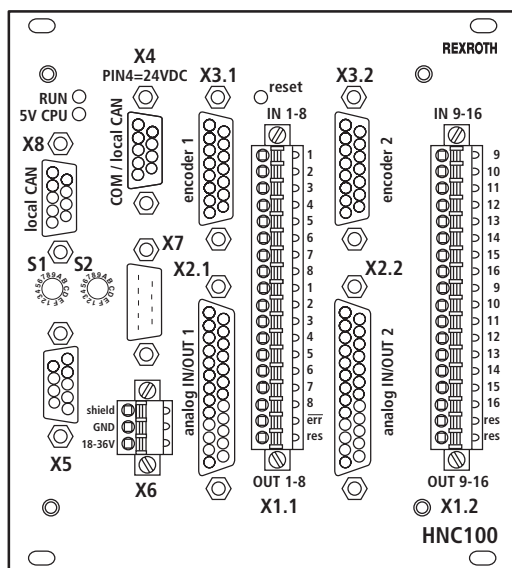

X5: Communication with higher-level control			
Pin	PROFIBUS DP	INTERBUS-S (OUT)	
1	n.c.		DO 2
2	n.c.		DI 2
3	RxD/TxD-P		GND 2
4	CNTR-P		n.c.
5	DGND		U <sub>dd</sub>
6	VP		/DO 2
7	n.c.		/DI 2
8	RxD/TxD-N		n.c.
9	n.c.		BCI

X2.1: Analog IN / OUT1		
Pin	1	U <sub>in</sub> 1 + I <sub>in</sub> 1 -
	2	U <sub>in</sub> 1 -
	3	U <sub>in</sub> 2 + I <sub>in</sub> 2 -
	4	U <sub>in</sub> 2 -
	5	res
	6	res
	7	res
	8	res
	9	res
	10	res
	11	analog_GND
	12	U <sub>ref</sub> = + 10 V
	13	U <sub>ref</sub> = - 10 V
	14	I <sub>out</sub> 1
	15	U <sub>out</sub> 1
	16	U <sub>out</sub> 3
	17	res
	18	
	19	I <sub>in</sub> 1 + I <sub>in</sub> 2 +
	20	res
	21	res
	22	U <sub>imp</sub> 1
	23	U <sub>imp</sub> 2
	24	res
	25	res

X2.2: Analog IN / OUT2		
Pin	1	U <sub>in</sub> 3 + I <sub>in</sub> 3 -
	2	U <sub>in</sub> 3 -
	3	U <sub>in</sub> 4 + I <sub>in</sub> 4 -
	4	U <sub>in</sub> 4 -
	5	res
	6	res
	7	res
	8	res
	9	res
	10	res
	11	analog_GND
	12	U <sub>ref</sub> = + 10 V
	13	U <sub>ref</sub> = - 10 V
	14	I <sub>out</sub> 2
	15	U <sub>out</sub> 2
	16	U <sub>out</sub> 4
	17	res
	18	
	19	I <sub>in</sub> 3 + I <sub>in</sub> 4 +
	20	res
	21	res
	22	U <sub>imp</sub> 3
	23	U <sub>imp</sub> 4
	24	res
	25	res

X7: Communication with higher-level control			
Pin	CANopen	Inductive	INTERBUS-S (IN)
1	n.c.	Supply 1 +	DO1
2	CAN_L	Supply 1 -	DI1
3	CAN_GND	Signal 1 +	GND1
4	n.c.	Signal 1 -	n.c.
5	n.c.	Supply 2 +	n.c.
6	n.c.	Supply 2 -	/DO1
7	CAN_H	Signal 2 +	/DI1
8	n.c.	Signal 2 -	n.c.
9	n.c.	Sync IN/OUT	n.c.

**Connector pinout VT-HNC100-1-2X/-24...** (single-axis variant)

**Note!**

The pins identified with "res" are reserved and must not be connected..

**S1, S2:**  
Address,  
baud rate  
CAN

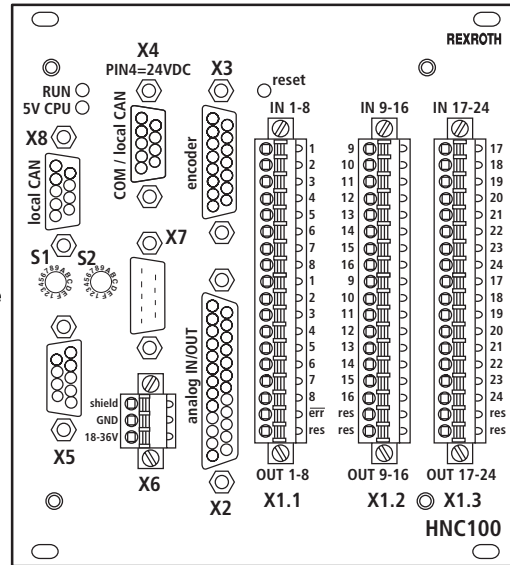

X2: Analog IN / OUT			
Pin	1	$U_{in} 1 +$	$I_{in} 1 -$
	2	$U_{in} 1 -$	
	3	$U_{in} 2 +$	$I_{in} 2 -$
	4	$U_{in} 2 -$	
	5	$U_{in} 3 +$	$I_{in} 3 -$
	6	$U_{in} 3 -$	
	7	$U_{in} 4 +$	$I_{in} 4 -$
	8	$U_{in} 4 -$	
	9	$I_{out} 2$	
	10	$U_{out} 2$	
	11	analog_GND	
	12	$U_{ref} = + 10 V$	
	13	$U_{ref} = - 10 V$	
	14	$I_{out} 1$	
	15	$U_{out} 1$	
	16	$U_{out} 3$	
	17	$U_{out} 4$	
	18		$I_{in} 1 +$
	19		$I_{in} 2 +$
	20		$I_{in} 3 +$
	21		$I_{in} 4 +$
	22	$U_{imp} 1$	
	23	$U_{imp} 2$	
	24	$U_{imp} 3$	
	25	$U_{imp} 4$	

X6: Power supply		
Pin	1	Shield
	2	GND
	3	18 - 36 VDC

X5: Communication with higher-level control			
Pin	PROFIBUS DP	INTERBUS-S (OUT)	
1	n.c.	DO 2	
2	n.c.	DI 2	
3	RxD/TxD-P	GND 2	
4	CNTR-P	n.c.	
5	DGND	$U_{dd}$	
6	VP	/DO 2	
7	n.c.	/DI 2	
8	RxD/TxD-N	n.c.	
9	n.c.	BCI	

X7: Communication with higher-level control			
Pin	CANopen	Inductive	INTERBUS-S (IN)
1	n.c.	Supply 1 +	DO1
2	CAN_L	Supply 1 -	DI1
3	CAN_GND	Signal 1 +	GND1
4	n.c.	Signal 1 -	n.c.
5	n.c.	Supply 2 +	n.c.
6	n.c.	Supply 2 -	/DO1
7	CAN_H	Signal 2 +	/DI1
8	n.c.	Signal 2 -	n.c.
9	n.c.	Sync IN/OUT	n.c.

X3: encoder		
Pin	Incremental	SSI
1	/Ua 2	
2		Clocking
3	Ua 0	
4	/Ua 0	
5	Ua 1	Daten
6	/Ua 1	/Daten
7		/Clocking
8	Ua 2	
9	res	
10	0 VN	
11	res	
12	5 VTTL (max. 150 mA)	
13	res	
14	24 VN (max. 200 mA)	
15	res	

X1.1 to X1.3: Digital IN/OUT			
Pin	X1.1	X1.2	X1.3
1	IN1	IN9	IN17
2	IN2	IN10	IN18
3	IN3	IN11	IN19
4	IN4	IN12	IN20
5	IN5	IN13	IN21
6	IN6	IN14	IN22
7	IN7	IN15	IN23
8	IN8	IN16	IN24
9	OUT1	OUT9	OUT17
10	OUT2	OUT10	OUT18
11	OUT3	OUT11	OUT19
12	OUT4	OUT12	OUT20
13	OUT5	OUT13	OUT21
14	OUT6	OUT14	OUT22
15	OUT7	OUT15	OUT23
16	OUT8	OUT16	OUT24
17	/error	res	res
18	res	res	res

X4: COM / local CAN		
Pin	1	CAN_GND
	2	TxD
	3	CTS
	4	24 VN
	5	0 VN
	6	RxD
	7	RTS
	8	CAN_H
	9	CAN_L

X8: Local CAN		
Pin	1	CAN_GND
	2	res
	3	res
	4	res
	5	res
	6	res
	7	res
	8	CAN_H
	9	CAN_L

**Unit dimensions** (dimensions in mm)

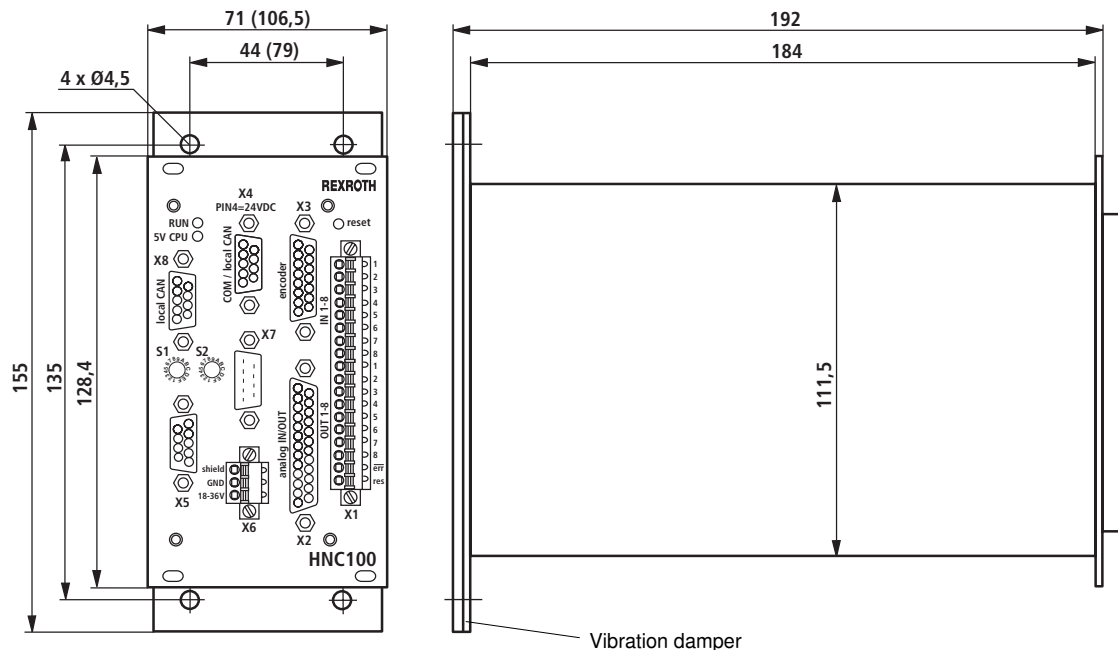

( ) ... dimensions are valid for VT-HNC100-2-2X/-16-.. and VT-HNC100-1-2X/-24-..

**Engineering / maintenance notes / supplementary information**

---

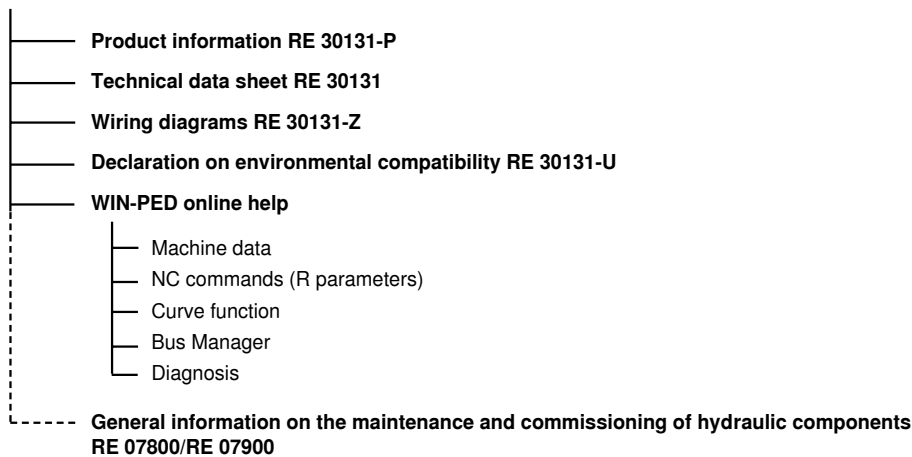
**Product documentation for VT-HNC100, component series 2X**

Commissioning software and documentation on the Internet: [www.boschrexroth.com/HNC100](http://www.boschrexroth.com/HNC100)

**Notes on use:**

The VT-HNC100...2X is exclusively intended for being integrated into a machine or system or assembled with other components to form a machine or system. The product may only be commissioned when it is integrated in the machine/system, for which it is intended.

Adhere to the operating conditions and performance limits specified in the technical data. The VT-HNC100...2X is used for the open and closed-loop control of position, pressure and velocity of electrohydraulic axes. For operation of the device an additional, higher-level control logic with corresponding I/O components is required, which, in conjunction with the VT-HNC100...2X, holistically control the motion sequence of the machine and also monitor it with regard to safety.

The VT-HNC100...2X must not be used in explosive atmospheres.

The VT-HNC100...2X is technical equipment that is not intended for private use.

## **Engineering / maintenance notes / supplementary information**

---

### **Engineering notes:**

- If electromagnetic interference has to be expected, take suitable measures for ensuring the function (depending on the application, e.g. shield, filtration)!
- Use low-capacitance cables; whenever possible, establish cable connections without intermediate terminals.
- Electromagnetic sources of interference (e.g. frequency converters) must not be installed in the direct vicinity of the control electronics.
- Power cables must not be routed in the direct vicinity of the controller card.
- Do not install cables of the control electronics in the direct vicinity of power cables.
- Install sensor cables separately.
- The distance to aerial lines, radio sources and radar equipment must be at least 1 meter.
- Use highly flexible CU conductors (min 2.5 mm<sup>2</sup>) for connecting the system ground!  
The system ground is an essential, integral part of EMC protection of the controller card. It dissipates interference that is transported to the controller card via data and supply voltage cables. This function can only be ensured, if the system ground itself does not inject interference into the controller card. Rexroth recommends that also solenoid cables be shielded.
- Electrical signals brought out via control electronics (e.g. signal "no error") must not be used for switching safety-relevant machine functions (see also European standard "Safety requirements for fluid power systems and components - hydraulics", EN 982.)
- For further notes, see WIN-PED 5 online help

### **Maintenance notes**

- The devices are tested in the factory and shipped with default settings.
- Only complete devices can be repaired. The repaired components will again be returned with default settings. User-specific settings are not retained. The operator is responsible for reloading the corresponding user parameters and programs.

## Notes

---

Bosch Rexroth AG  
Hydraulics  
Zum Eisengießer 1  
97816 Lohr am Main, Germany  
Phone +49 (0) 93 52 / 18-0  
Fax +49 (0) 93 52 / 18-23 58  
documentation@boschrexroth.de  
www.boschrexroth.de

© This document, as well as the data, specifications and other information set forth in it, are the exclusive property of Bosch Rexroth AG. It may not be reproduced or given to third parties without its consent. The data specified above only serve to describe the product. No statements concerning a certain condition or suitability for a certain application can be derived from our information. The information given does not release the user from the obligation of own judgment and verification. It must be remembered that our products are subject to a natural process of wear and aging.

# HYQUIP

New Brunswick Street Horwich Bolton BL6 7JB UK  
Tel: +44 (0)1204 699959 Fax: +44 (0)1204 699542  
Email: [enquiries@hyquip.co.uk](mailto:enquiries@hyquip.co.uk) Web: [www.hyquip.co.uk](http://www.hyquip.co.uk)

## Notes

---

Bosch Rexroth AG  
Hydraulics  
Zum Eisengießer 1  
97816 Lohr am Main, Germany  
Phone +49 (0) 93 52 / 18-0  
Fax +49 (0) 93 52 / 18-23 58  
documentation@boschrexroth.de  
www.boschrexroth.de

© This document, as well as the data, specifications and other information set forth in it, are the exclusive property of Bosch Rexroth AG. It may not be reproduced or given to third parties without its consent. The data specified above only serve to describe the product. No statements concerning a certain condition or suitability for a certain application can be derived from our information. The information given does not release the user from the obligation of own judgment and verification. It must be remembered that our products are subject to a natural process of wear and aging.

# HYQUIP

New Brunswick Street Horwich Bolton BL6 7JB UK  
Tel: +44 (0)1204 699959 Fax: +44 (0)1204 699542  
Email: [enquiries@hyquip.co.uk](mailto:enquiries@hyquip.co.uk) Web: [www.hyquip.co.uk](http://www.hyquip.co.uk)

## Notes

---

© This document, as well as the data, specifications and other information set forth in it, are the exclusive property of Bosch Rexroth AG. It may not be reproduced or given to third parties without its consent. The data specified above only serve to describe the product. No statements concerning a certain condition or suitability for a certain application can be derived from our information. The information given does not release the user from the obligation of own judgment and verification. It must be remembered that our products are subject to a natural process of wear and aging.

