

Amplifier module for controlling <sup>1)</sup>  
explosion-protected  
proportional directional valves  
4WRA...XE, 3DREP 6...XE and 4WRZ...XE

RE 30228-200/07.05 1/8

Type VT-MSPA2-200

Component series 1X



H 7282

## Table of contents

Contents	Page
Features	1
Ordering code	2
Functional description	2
Block circuit diagram	3
Technical data	4
Characteristic curves	5
Terminal assignment	6
View / unit dimensions	6
Important notes / adjustment recommendations	7

## Features

- Amplifier is **not** subject to Directive 94/9/EC (ATEX Directive)
  - In conjunction with Rexroth safety module VT-MUXA2, suitable for controlling proportional directional valves without electrical position feedback, types 4WRA...XE, 3DREP 6...XE and 4WRZ...XE
  - Command value input  $\pm 10$  V (differential input)
  - Ramp generator with separately adjustable "up/down" ramp times
  - Characteristic curve correction through separately adjustable step-change heights
  - Enable input
  - Reverse polarity protection for voltage supply
  - Power supply unit with DC/DC converter without raised zero point for internal supply
  - LED lamps:
    - Ready for operation (green)
    - Enable (yellow)
- Suitable power supply units:
- If power is to be provided also for safety module VT-MUXA: Type VT-NE40-1X to data sheet RE 29891, permissible ambient temperature 40 °C
  - Without supply of safety module VT-MUXA: Type VT-NE30-1X to data sheet RE 29929

<sup>1)</sup> To achieve the prescribed level of safety when operating one of the listed valves in a potentially explosive atmosphere, this amplifier module must be connected to safety module VT-MUXA2. In this context, read operating instructions RE 30290-B0 for the safety module!

## Ordering code

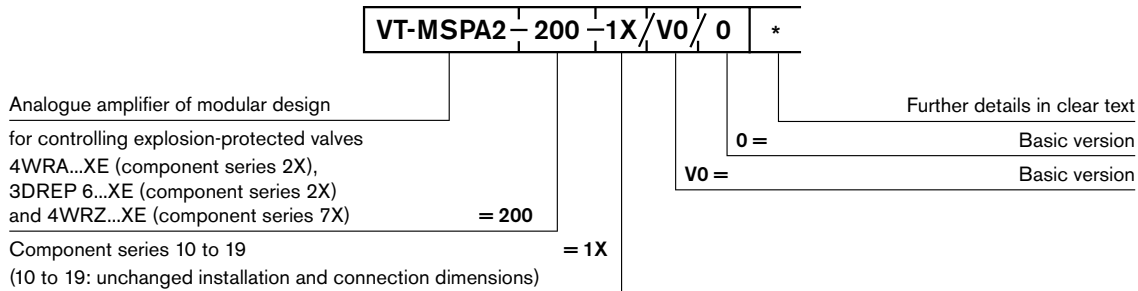

## Functional description

### General

The amplifier modules are to be snapped onto hat rails according to EN 60715. They are electrically connected by means of screw terminals. The modules are operated with 24 V DC.

### Power supply unit (1)

The amplifier modules are shipped with a power supply unit with switch-on current limitation. It provides all internally required positive and negative supply voltages. The switch-on current limitation prevents excessive switch-on current peaks.

### Command value

The internal command value signal is generated from the external command value signal applied to differential input (2).

A positive command value causes an increase in current in solenoid "b" and therefore a flow in the valve from P → A and from B → T.

A negative command value causes an increase in current in solenoid "a" and therefore a flow in the valve from P → B and from A → T.

### Enable function (10)

The enable function is used for enabling the current output stages and passing the internal command value signal on to the ramp generator. The enable signal is signalled by an LED on the front panel. When the enable is granted, the internal command value (with optional command value feedforward) changes with the set ramp time. A valve does therefore not open suddenly when activated.

### Ramp generator (3)

The ramp generator limits the gradient of the control output. The downstream step functions do not extend or shorten the ramp time.

Note on the adjustment and measurement of the ramp time:

Value at measuring socket "t <" or "t >" $U_t$ in V	5	3	2
Current ramp time ( $\pm 20\%$ ) $t$ in ms	20	33	50

$U_t$ in V	1	0.5	0.3	0.2	0.1	0.05	0.03	0.02
$t$ in ms	100	200	333	500	1000	2000	3333	5000

The following is valid:

$$t = \frac{100 \text{ Vms}}{U_t}$$

Example: Measured  $U_t = 5 \text{ V}$

results in  $t = \frac{100 \text{ Vms}}{5 \text{ V}} = 20 \text{ ms}$

### Characteristic curve generator (4)

The adjustable characteristic curve generator can be used to adjust the step-change height separately for positive and negative signals to the requirements of the hydraulic system. The actual course of the characteristic curve through the zero point is not stepped, but linear. (Characteristic curve, see page 5)

### Amplitude limiter (5)

The command value is limited to approx.  $\pm 110\%$  of the nominal range.

### Current regulator (6)

The current is regulated in dependence upon the command value.

### Current output stage (7)

The current output stage generates the clocked solenoid current for the proportional valve. The nominal solenoid current is 1000 mA per output. The output stage outputs are short-circuit-proof. In the event of an internal fault signal or missing enable, the output stages are de-energised.

### Clock-pulse generator (8)

The clock-pulse generator generates clock frequency  $f$  of the output stages.

$f = 150 \text{ Hz} \dots 400 \text{ Hz}$ , adjustable with the help of potentiometer "f" (pre-set to 240 Hz)

### Fault detector (10)

Monitors the solenoid cables for cable break and the output stage for overcurrent.

### Command value inversion (11)

The command value generated from the input signal and the zero point offset signal can be inverted by means of an external signal.

**Block circuit diagram**

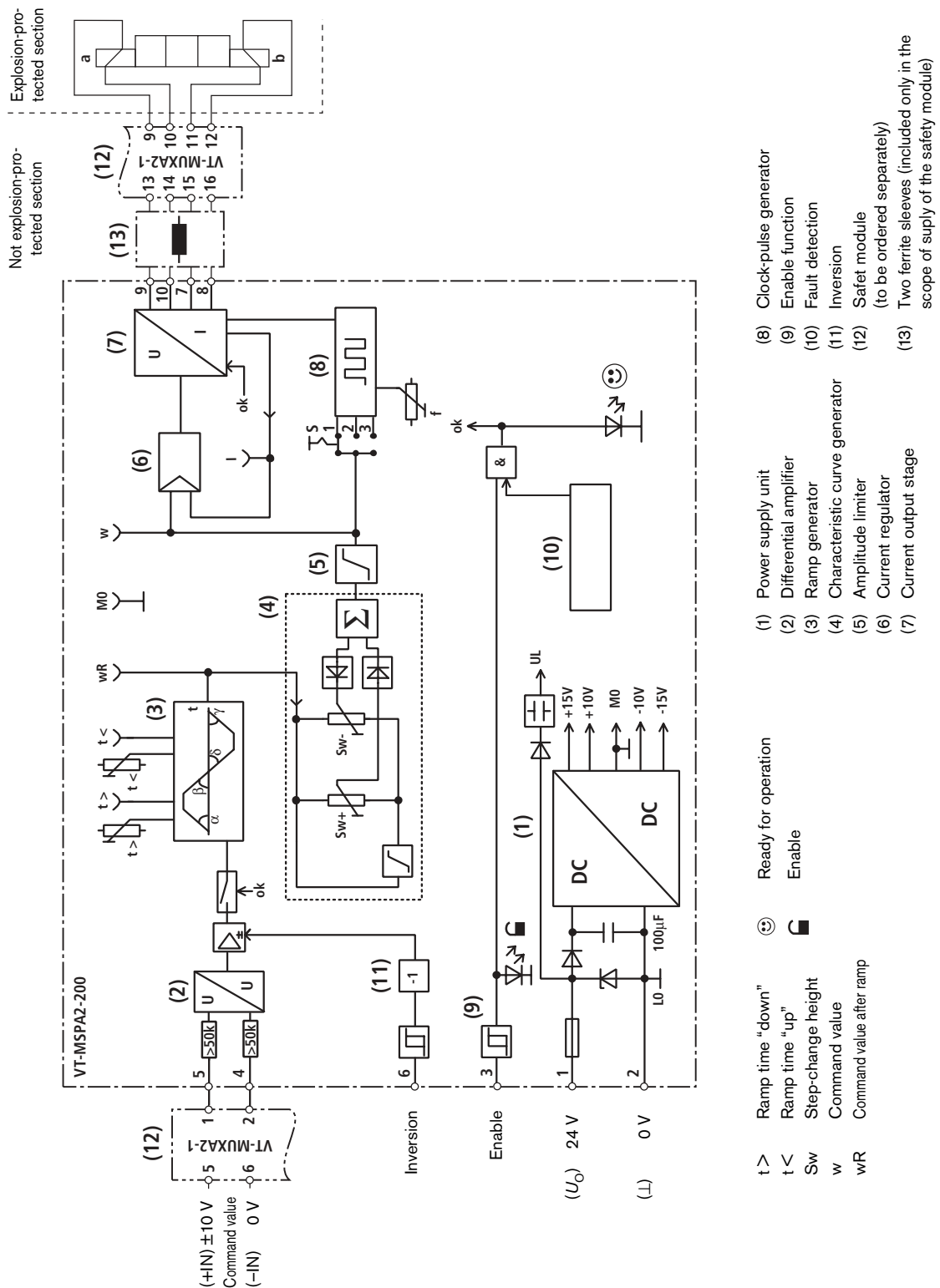

**Technical data** (for applications outside these parameters, please consult us!)

Operating voltage	Nominal value	$U_O$	24 VDC
	Maximum value	$u_O(t)_{max}$	35 V
	Minimum value	$u_O(t)_{min}$	18 V
Power consumption		$P$	< 24 VA
Current consumption		$I$	< 1 A
Fuse	Thermal overload fuse (with reset when temperature falls below a threshold )		
Inputs			
Analogue	Command value (differential input)	$U_i$	0 ... $\pm 10$ V; $R_i > 50$ k $\Omega$
Digital	Enable	ON	$U$ 8.5 V ... $U_O$ ; $R_i > 100$ k $\Omega$
		OFF	$U$ 0 ... 6.5 V; $R_i > 100$ k $\Omega$
	Inversion	ON	$U$ 8.5 V ... $U_O$ ; $R_i > 100$ k $\Omega$
		OFF	$U$ 0 ... 6.5 V; $R_i > 100$ k $\Omega$
Adjustment ranges			
	Clock frequency	$f$	adjustable from 150 Hz ... 400 Hz, preset to 240 Hz
	Ramp times (potentiometers "t <" and "t >")	$t <, t >$	20 ms ... 5 s
	Step-change height (potentiometers "Sw+" and "Sw-")		0 % ... 50 %
Outputs			
	Current output stages	$I$	0 to 1000 mA, short-circuit-proof; clocked
Measuring sockets	Ramp time "t <"	$U$	20 mV ... 5 V
	Ramp time "t >"	$U$	20 mV ... 5 V
	Actual value "I"	$U$	0 ... $\pm 1000$ mV (value measured in mV $\triangleq$ solenoid current in mA)
	Command value "w"	$U$	0 ... $\pm 10$ V
	Command value after ramp "wR"	$U$	0 ... $\pm 10$ V
Type of connection	Screw terminals		
Connection cross-section	$A$	0.5 ... 2.5 mm <sup>2</sup>	
Type of mounting	Hat rail TH 35-7.5 to EN 60715		
Type of protection	IP 20 to EN 60529		
Dimensions (W x H x D)	See unit dimensions		
Permissible operating temperature range	$\vartheta$	0 ... +50 °C	
Storage temperature range	$\vartheta$	-25 °C ... +70 °C	
Weight	$m$	0.14 kg	

## Characteristic curves

Dependence of output current on command value voltage

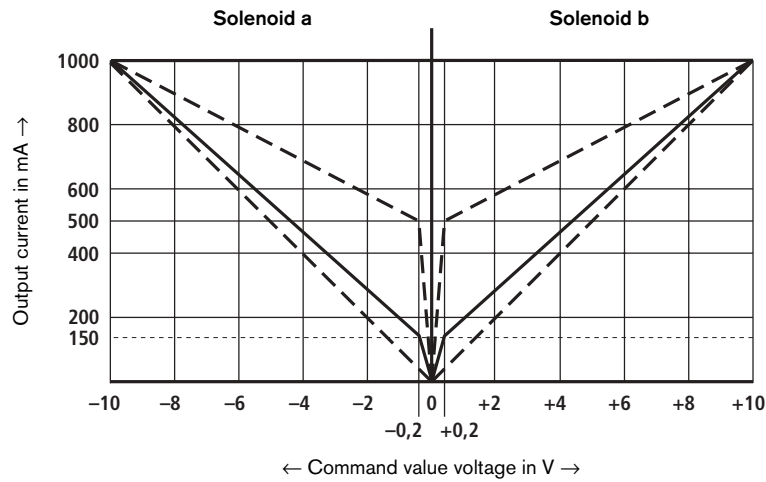

Adjustment range of step-change height of output current: 0 ... 500 mA  
 Factory setting: 150 mA



## Important notes / adjustment information

### Risk of explosion in the case of incorrect installation!

To achieve the prescribed level of safety when operating one of the listed valves in a potentially explosive atmosphere, this amplifier module must be connected to safety module VT-MUXA2.

In this context, read operating instructions RE 30290-B0 for the safety module!

This amplifier module and safety module VT-MUXA may only be installed **outside** potentially explosive atmospheres!

The amplifier module is **not** subject to Directive 94/9/EC (ATEX Directive)!

Further notes:

- The amplifier module may only be wired when disconnected from the power supply!
- Do not lay signal cables near power cables and lines!
- Do not use free-wheeling diodes in solenoid cables!
- The distance to aerial lines, radio sources and radar equipment must be at least 1 m!
- Always shield command value cables and connect the shield to the protective earth (PE) on the module side!
  - Also shield solenoid cables!
  - For solenoid cables up to 50 m length, use cable type LiYCY 1.5 mm<sup>2</sup>!
  - In the case of greater lengths, please consult us!
  - For applications and use in conjunction with safety module VT-MUXA, please observe the installation instructions in the associated operating instructions RE 30290-B0.
- Use relays with gold-plated contacts for passing on command values (small voltages, small currents)!
- Measurements on the module may only be taken with instruments with  $R_i > 100 \text{ k}\Omega$ .
- For adjusting the potentiometers, use a screwdriver with a blade width of 4 mm!
- In the case of strongly fluctuating operating voltages, it may be required to install an external smoothing capacitor having a capacitance of at least 2200  $\mu\text{F}$ .  
Recommendation: Capacitor module VT 11073 (see RE 29750), sufficient for up to 3 amplifier modules,
- In conjunction with safety module VT-MUXA, the operating voltage must be directed via a capacitor module.  
The solenoid current connections to safety module VT-MUXA must be routed via ferrite sleeves. These ferrite sleeves are included in the scope of supply of safety module VT-MUXA.
- The clock frequency is factory-set to 240 Hz. Turning of potentiometer "f" results in a change in the valve hysteresis and can cause annoying noise.

## Adjustment information

Preconditions: The system-specific connections must have been made.

Signal	Adjustment
Ramp time	- Adjust ramp time according to formula or table (see functional description of "ramp generator") and check at measuring sockets "t >" and "t <"
Step-change height	- Apply enable signal - Apply an external command value of +0.3 V and adjust the measured signal at "wR" to +0.3 V - Adjust the required positive step-change height using potentiometer "Sw+" - Apply an external command value of -0.3 V and adjust the measured signal at "wR" to -0.3 V - Adjust the required positive step-change height using potentiometer "Sw-" Note: With external command value feedforward, the latter must result in at least +0.3 V / -0.3 V at measuring socket "wR".
Clock frequency	Factory setting: $f = 240 \text{ Hz}$ <b>Note:</b> The frequency can be newly set with the help of a digital multimeter that is capable of measuring frequencies. Measurement at connecting terminals 7 or 9 against 2 (ground).

## Notes

---

© This document, as well as the data, specifications and other information set forth in it, are the exclusive property of Bosch Rexroth AG. It may not be reproduced or given to third parties without its consent.

The data specified above only serve to describe the product. No statements concerning a certain condition or suitability for a certain application can be derived from our information. The information given does not release the user from the obligation of own judgment and verification. It must be remembered that our products are subject to a natural process of wear and aging.

