

Analogue amplifier module

RE 29865-01/08.06 1/4
Replaces: RE 29865-D/05.00

Type VT 17334 (mod. VT 11131)

Series 1X



H3786_d
Basic amplifier type VT 11131-1X

Table of contents

Contents	Page
Features	1
Ordering code	2
Functional description	2
Block circuit diagram / pin assignment	2
Technical data	3
Output characteristic curve	3
Terminal assignment	4
Unit dimensions	4
Engineering / maintenance notes / supplementary information	4

Features

- Basic amplifier: VT 11131-1X
- Changed compared with base:
 - $I_{max} = 2.0 \text{ A}$
 - power consumption 50 VA at $U_B 24 \text{ V}$
 - current consumption 1.7 A
- Suitable for controlling proportional pressure control valves without electrical position feedback
- Differential input
- One clocked output stage
- Function generator
- Ramp generator with adjustable ramp time (up and down ramp can be adjusted separately)
- Adjustable current regulator
- Reverse voltage protection for voltage supply
- Indication of solenoid energisation by LED (brightness of LED proportional to solenoid current)

Ordering code

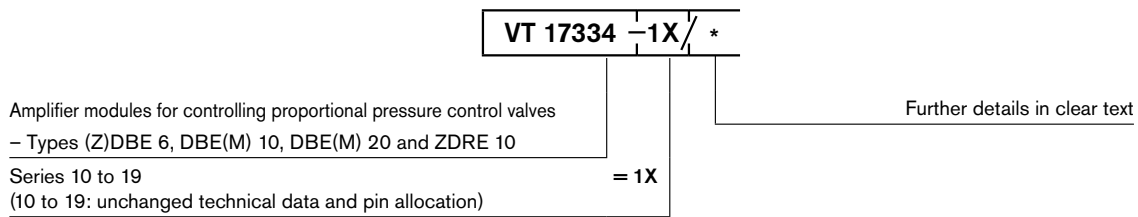

Functional description

The amplifier module is suitable for controlling a proportional solenoid. The amplifier modules are to be snapped onto top hat rails according to EN 60715. The electrical connections are made by means of screw terminals. The modules are operated using 24V DC.

The solenoid current (actual value) is measured and compared with the externally provided command value. Any differences occurring between actual and command value, caused e.g. by changes in the solenoid temperature or operating voltage, are balanced.

The activation of solenoid control is indicated by LED "H3", the brightness of which is proportional to the solenoid current.

The following values can be adjusted from outside by means of assigned trimming potentiometers:

- Ramp time, separately for up and down ramp (by means of R11, R12 → t_{max} approx. 5 s)
- Gradient of the output characteristic curve (by means of R1, R2)

Block circuit diagram / pin assignment

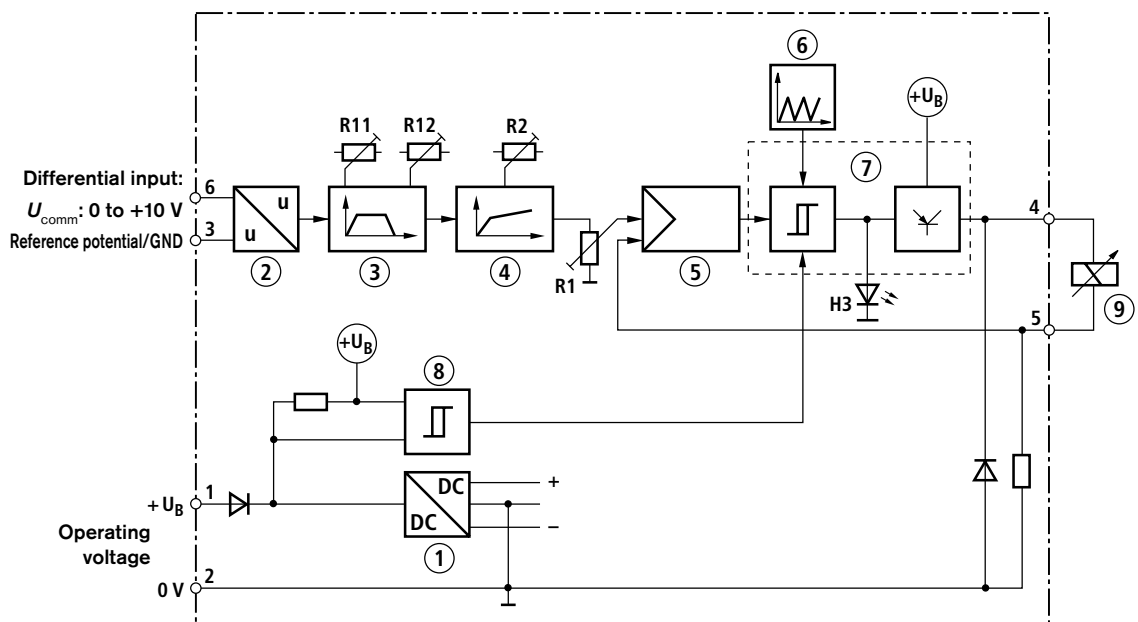

- | | | | |
|---|------------------------|---|-----------------------|
| 1 | Power supply unit | 6 | Clock-pulse generator |
| 2 | Differential amplifier | 7 | Output stage |
| 3 | Ramp generator | 8 | Switching stage |
| 4 | Function generator | 9 | Proportional solenoid |
| 5 | Current regulator | | |

Technical data (for applications outside these parameters, please consult us!)

Operating voltage	U_O	24 VDC +40 % -10 %
Operating range:		
– Upper limit value	$u_B(t)_{max}$	35 V
– Lower limit value	$u_B(t)_{min}$	21 V
Power consumption	$P_{S max}$	38 VA
Current consumption	I_{max}	1.7 A
Fuse		Electronic short-circuit protection of the solenoid
Inputs:		
– Command value (differential input)	U_{comm}	0 to +10 V; R_i approx. 10 k Ω
Adjustment ranges:		
– Output current	I	$I_{10\%}$ to I_{max}
– Ramp time	t	approx. 50 ms to approx. 5 s
Outputs:		
– Solenoid current / resistance	I_{max}	2.0 A; $R_{(20)} = 5.4 \Omega$
– Clock-pulse frequency of output stage	f	300 Hz ± 15 %
Type of connection		6 screw terminals
Type of mounting		Top hat rail TH 35-7.5 to EN 60715
Type of protection		IP 20 to EN 60529
Dimensions (W x H x D)		25 x 79 x 85.5 mm
Permissible operating temperature range	ϑ	0 to +50 °C
Storage temperature range	ϑ	-25 to +85 °C
Weight	m	0.13 kg

Note:

For details regarding **environment simulation tests** in the field of climate, see RE 30309-U (declaration on environmental compatibility).

In order to guarantee a sufficient coolness the modul must be assembled with a minimum distance of 20 mm to other devices.

Output characteristic curve

VT 17334

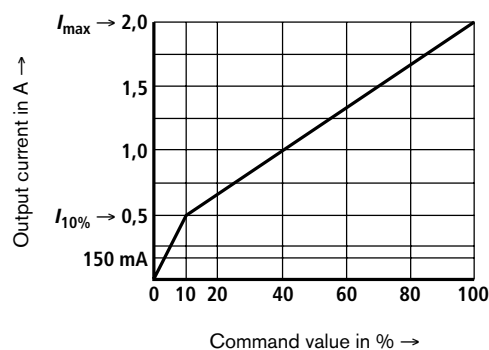

Terminal assignment

Operating voltage	$+U_o$	1	4	
	0 V	2	5	
	Reference potential	3	6	$+U_{comm}$

Proportional solenoid

Terminals 3 and 6: Differential input

Unit dimensions (Dimensions in mm)

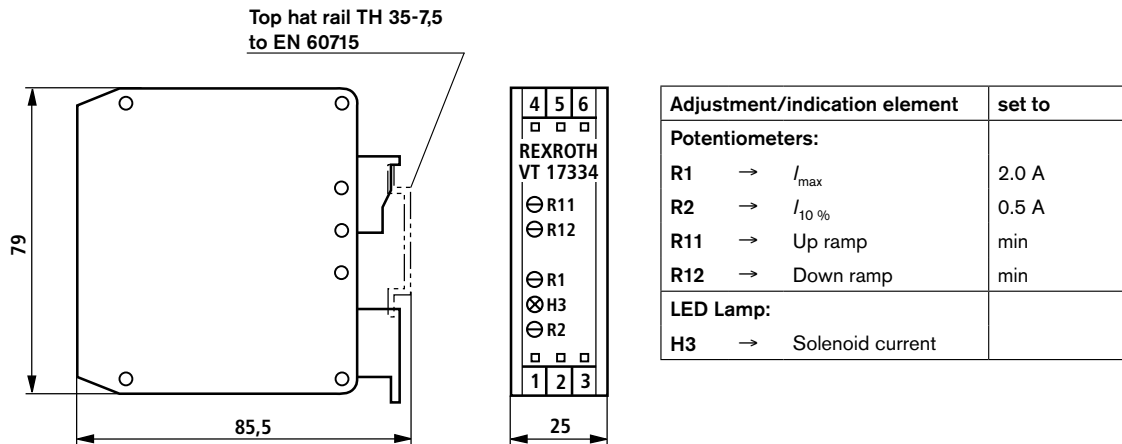

Engineering / maintenance notes / supplementary information

- The amplifier module may only be wired when disconnected from the power supply!
- The distance to radio equipment must be sufficiently large ($\gg 1$ m)!
- Command value cables must always be shielded and **not** laid near power cables; shield solenoid cables!
- Do not use free-wheeling diodes in the solenoid cables!
- In the case of heavy fluctuations in the operating voltage, it may become necessary to install an external smoothing capacitor having a capacitance of at least 2200 μ F.
Recommendation: Capacitor module type VT 11073 (se RE 29750); sufficient for up to 3 amplifier modules!

© This document, as well as the data, specifications and other information set forth in it, are the exclusive property of Bosch Rexroth AG. Without their consent it may not be reproduced or given to third parties.

The data specified above only serve to describe the product. No statements concerning a certain condition or suitability for a certain application can be derived from our information. The information given does not release the user from the obligation of own judgment and verification. It must be remembered that our products are subject to a natural process of wear and aging.