

HYDAC

INTERNATIONAL

Pressure Filter MDF

Flow rates up to 350 l/min

Pressure range up to 280 bar

Material: Cast iron - Steel

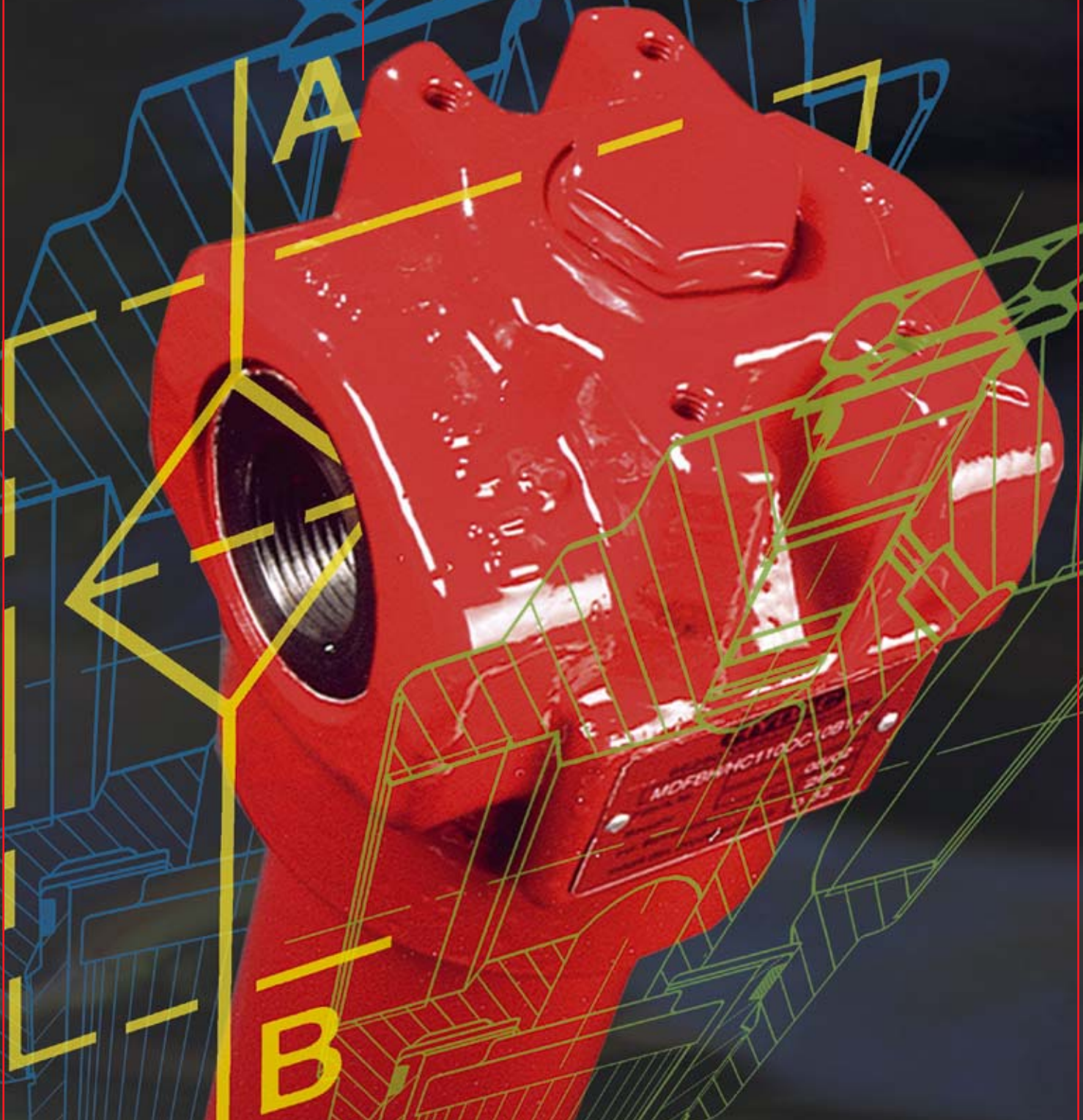

1. TECHNICAL SPECIFICATIONS

1.1 FILTER HOUSING

Construction

The filter housings are designed in accordance with international regulations. The filters consist of a filter head with a screw-on filter bowl.

Standard equipment:

- Port for clogging indicator in the filter head
- Either threaded or flange port
- Mounting holes in the head

1.2 FILTER ELEMENTS

Original HYDAC filter elements guarantee reliable function and protect hydraulic components and systems which are sensitive to contamination from wear and tear.

Performance and quality tests in accordance with international standards guarantee reliable operation of the filter.

Hydac filters are validated and their quality is continuously monitored according to the following standards.

- ISO 2941: Verification of collapse / burst resistance
 - ISO 2942: Verification of fabrication integrity and determination of first bubble point test
 - ISO 2943: Verification of material compatibility with fluids
 - ISO 3724: Verification of flow fatigue characteristics
 - ISO 3968: Evaluation of differential pressure versus flow characteristics
 - ISO 16889: Multi-pass method for evaluating filtration performance of a filter element
- In addition to guaranteeing retention and flow rate characteristics, the filter elements have excellent structural stability. The careful construction and mechanically stable support of the filter media guarantee above-average beta value stability and flow fatigue characteristics of the filter elements.
- The filter elements are available with the following collapse/burst stability values:
- | | |
|----------------------------|---------|
| Betamicon®(BN3HC): | 25 bar |
| Betamicon®(BH3HC): | 210 bar |
| Wire mesh (W): | 30 bar |
| Stainless steel fibre (V): | 210 bar |

1.3 CLOGGING INDICATORS

VM 5 D . 0 /-L220

Type of indicator

- VD differential pressure meas. up to 450 bar operating pressure
- VM differential pressure meas. up to 210 bar operating pressure

Pressure setting

- 5 5 bar standard, others on request

Indicator type

- B. = visual
- C. = electrical
- D. = visual/electrical

Modification number

- 0 the latest version is always supplied

Supplementary details

- V Viton
- W indicator suitable for oil-water emulsions HFA, HFC
- L.. light with corresponding voltage (24, 48, 110, 220 Volt)
- LED 2 light-emitting diodes up to 24 volt

For further details and other types of clogging indicator, please see **brochure no.: 7.050../..**

1.4 SEALS

Perbunan (=NBR)

1.5 SPECIAL MODELS AND ACCESSORIES

- Bypass valve in head, sited away from main flow
- Oil drain plug
- Seals in FPM, EPDM
- Test and inspection certificates

1.6 SPARE PARTS

See Original Spare Parts List and Maintenance Instructions.

1.7 COMPATIBILITY WITH OPERATING FLUIDS TO DIN ISO 2943:

- Hydraulic oils H to HLPD to DIN 51524
- Lubrication oils to DIN 51517, APJ, ACEA, DIN 51515, ISO 6743
- Compressor oils to DIN 51506
- Rapidly biodegradable operating fluids to VDMA 24568 HETG, HEES, HEPG
- Non-flam operating fluids HFC and HFD
- Operating fluids with high water content (> 50% water content) on request

For further details on filter elements:
Brochure no.: E 7.200../..

1.8 CERTIFICATES AND APPROVALS

- Test certificate 2.2
- Manufacturer's certificate O and M to DIN 55350, Part 18
- Other certificates on request

1.9 WARNING

- Filter housing must be earthed.
- When using electrical clogging indicators, before removing the clogging indicator connector, the electrical power supply to the system must be switched off.

2. GENERAL

Mounting

Inline filter

Temperature range

-30 °C to +100 °C
(-30 °C to -10 °C:
 p_{max} = 140 bar)

Pressure setting of the clogging indicator

Δp_a = 5 bar -0.5 bar

Other pressure settings on request

Cracking pressure of bypass valve

Δp_b = 6 bar +0.6 bar

Other cracking pressures on request

Circuit diagram for hydraulic systems

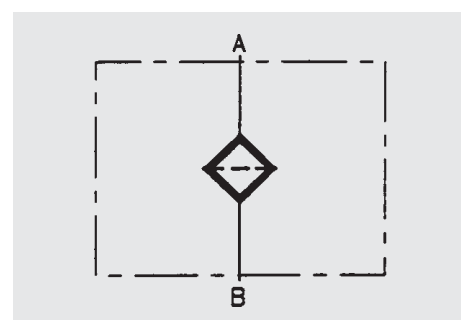

3. MODEL CODE (also order example)

MDF BN/HC 60 O C 10 D 1 . X /-L24

3.1. COMPLETE FILTER

Filter type _____

MDF

Filter material _____

- BN/HC Betamicron® (BN3HC)
- BH/HC Betamicron® (BH3HC)
- W Stainless steel wire mesh
- V Stainless steel fibre

Size of filter or element _____

MDF: 30/ 60/ 110/ 160/ 240

Operating pressure _____

Threaded port:

- L = 210 bar (VM clogging indicator)
- O = 280 bar (standard; VD clogging indicator)

Flange port

- L = 210 bar (3000 psi flange => VM indicator)
- O = 280 bar (6000 psi flange => VD indicator)

Type / Size of port _____

Type	Port	Filter size				
		30	60	110	160	240
B	G ½	●				
C	G ¾	●	●	●		
D	G 1		●	●		
E	G1 ¼				●	●
F	G1 ½				●	●
H	SAE DN 13	●				
I	SAE DN 20		●	●		
J	SAE DN 32				●	●

Standard models

Filtration rating in µm _____

- BN3HC, BH3HC, V : 3, 5, 10, 20
- W : 25, 50, 100, 200

Type of clogging indicator _____

- Y plastic blanking plug in indicator port
 - A steel blanking plug in indicator port
 - B visual indicator
 - C electrical indicator
 - D combined visual/electrical indicator
-] for other clogging indicators,
see brochure no. E 7.050./...

Type code _____

1

Modification number _____

- X the latest version is always supplied

Supplementary details _____

- B. bypass valve cracking pressure, B6 = 6 bar (no details = without bypass)
 - L... light with corresponding voltage (24V, 48V, 110V, 220V)
 - LED 2 light-emitting diodes up to 24 volt
 - SO 184 pressure release / oil drain plug
 - V FPM seals, filter suitable for rapidly biodegradable oils and phosphate ester (HFD-R)
 - W suitable for oil-water emulsions HFA, HFC (only necessary when using a clogging indicator or V or W elements)
-] only on clogging
indicators type D

3.1.1 Examples

Type	Operating pressure	Clogging indicator	Port
MDF BN/HC 60 O C 10 D ...	280 bar	VD	Threaded
MDF BN/HC 60 L C 10 D ...	210 bar	VM	Threaded
MDF BN/HC 60 O I 10 D ...	280 bar	VD	Flange 6000 PSI
MDF BN/HC 60 L I 10 D ...	210 bar	VM	Flange 3000 PSI

3.2. REPLACEMENT ELEMENT

0060 D 010 BN3HC /-V

Size

0030, 0060, 0110, 0160, 0240

Type

D

Filtration rating in μm

BN3HC, BH3HC, V : 3, 5, 10, 20

W : 25, 50, 100, 200

Filter material

BN3HC, BH3HC, V, W

Supplementary details

V = FPM seals, element suitable for rapidly biodegradable oils and phosphate ester (HFD-R)

W = suitable for oil-water emulsions HFA/HFC (only necessary for V and W elements)

4. FILTER SPECIFICATIONS

	MDF
p_{max}	280
Temperature range	-30°C to +100°C
Fatigue strength	Size 30 - 240: min 5 mill. cycles at 1.2 times the operating pressure
Pressure setting clogging indicator: Δp_a	5 bar
Type of clogging indicator	VM / VD
Material of filter head	GGG (cast iron)
Material of filter bowl	Steel
Cracking pressure of bypass	6 bar
Sizes	30, 60, 110, 160, 240

5. FILTER CALCULATION/SIZING

The total pressure drop of a filter at a certain flow rate is the sum of the housing Δp and the element Δp . The pressure drop can either be determined with the aid of our HFS Filter Selection Program, which is available free of charge, or by using the following graphs.

NEW: Sizing online at www.hydac.com (please click on the following buttons: Products - Filters - Electronic catalogue - Filter selection HFS)

5.1. ΔP -Q HOUSING GRAPHS TO ISO 3968

The housing graphs apply to mineral oil with a density of 0.86 kg/dm^3 and a kinematic viscosity of $30 \text{ mm}^2/\text{s}$ for the largest possible width per size. In this case, the differential pressure changes proportionally to the density.

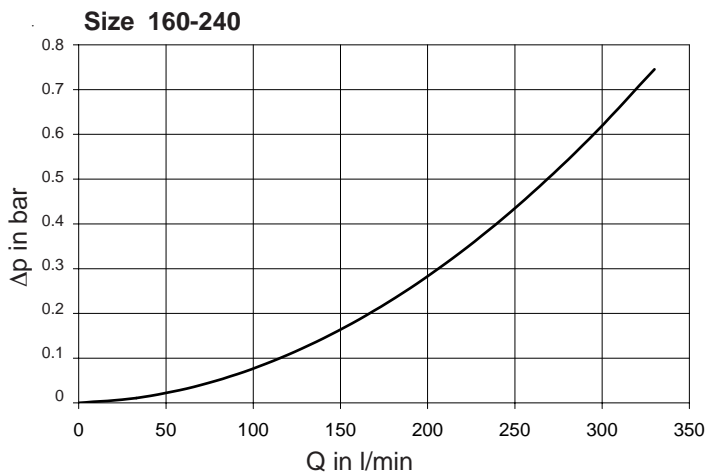
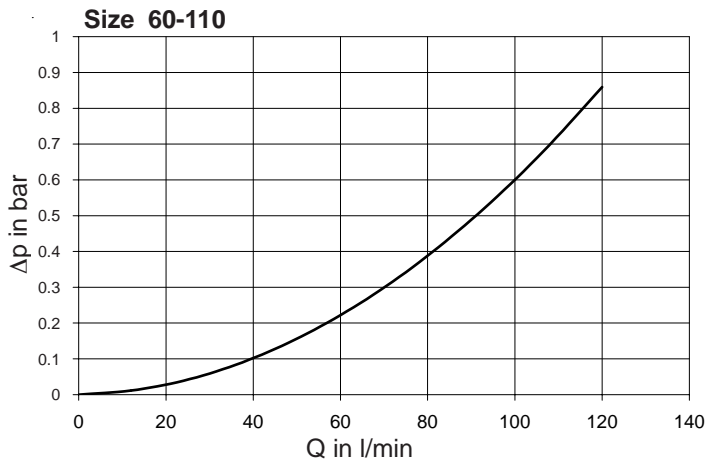
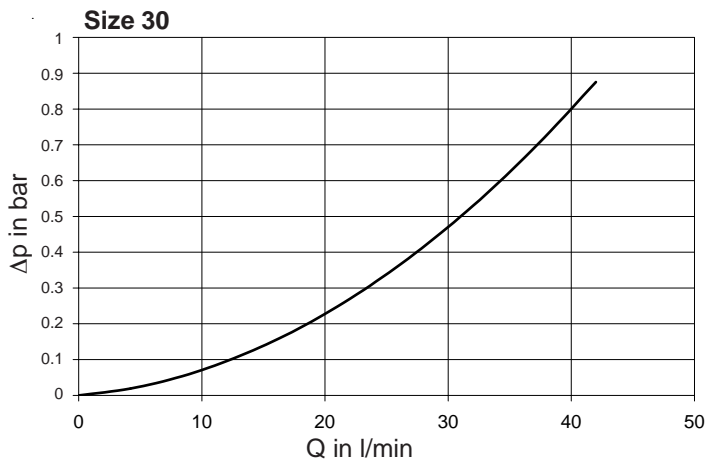

5.2. Δp -Q GRAPHS - FILTER ELEMENTS

The element graphs apply to mineral oil with a kinematic viscosity of $30 \text{ mm}^2/\text{s}$. The pressure drop changes proportionally to the change in viscosity (see Example 5.3).

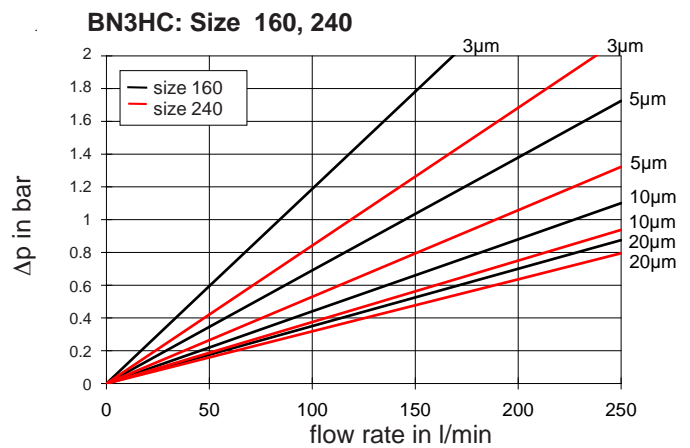
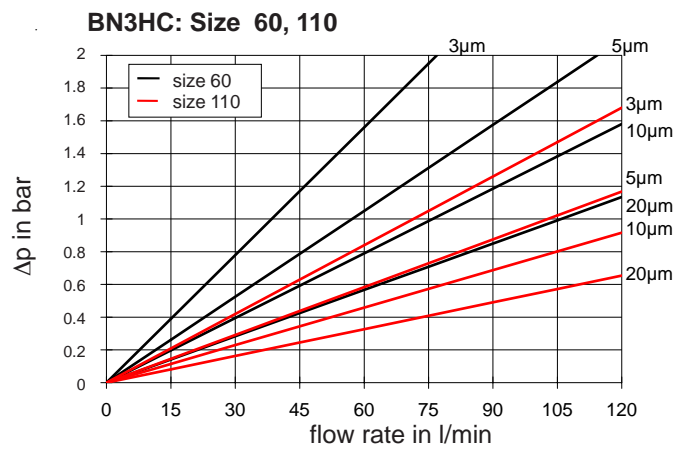
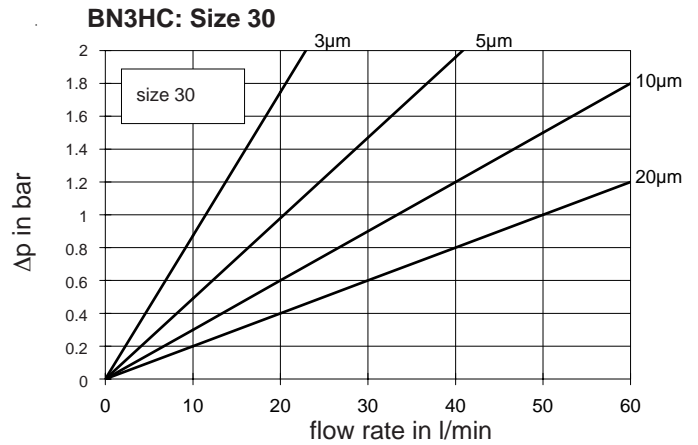

BH3HC: Size 30

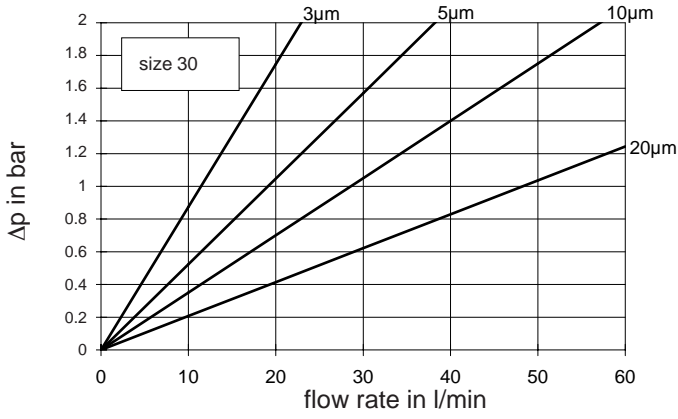

V: Size 60, 110

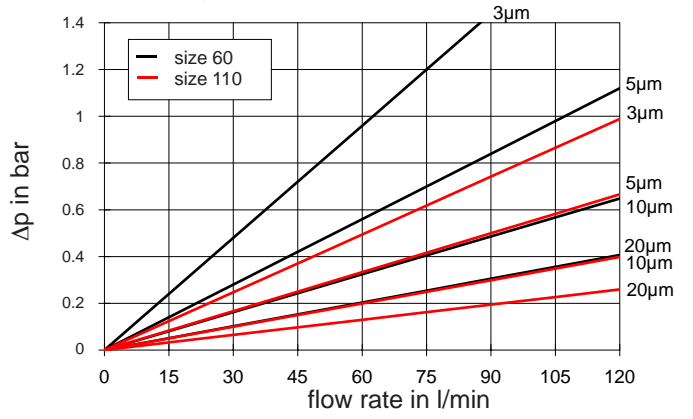

BH3HC: Size 60, 110

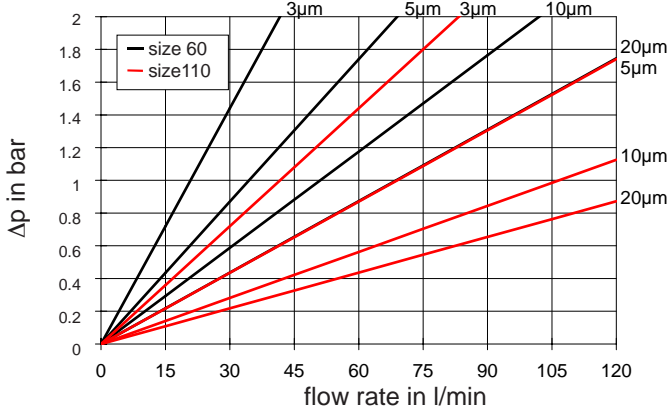

V: Size 160, 240

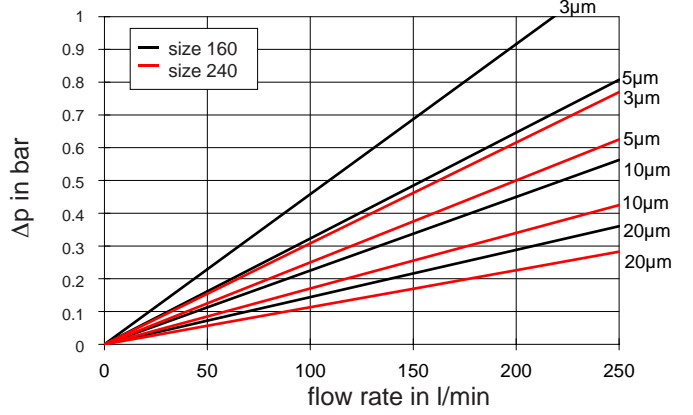

BH3HC: Size 160, 240

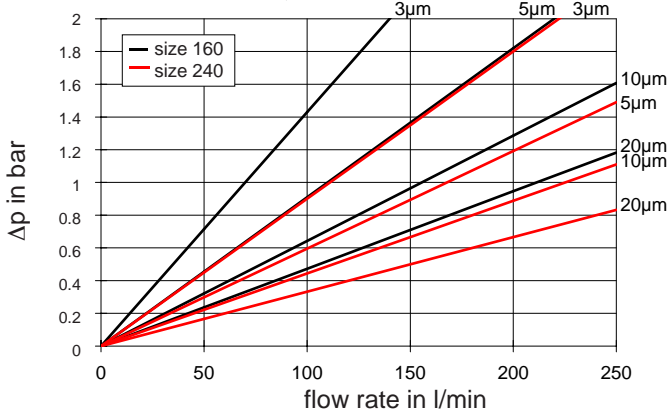

W

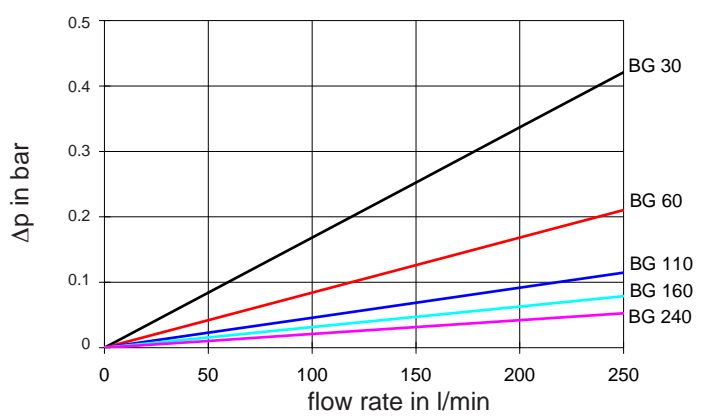

BG = Size

V: Size 30

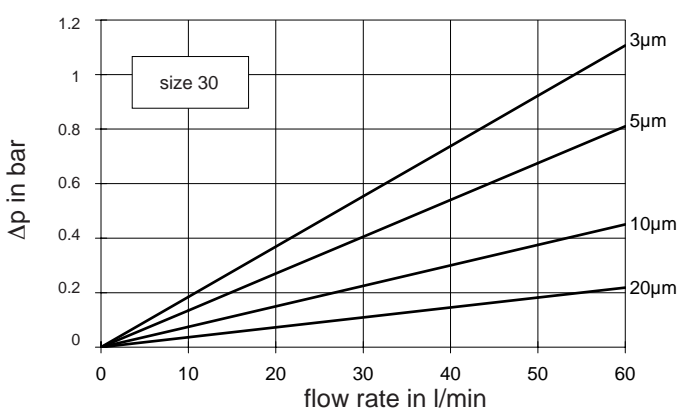

5.3. EXAMPLE

General

$$\Delta p_{\text{total}} = \Delta p_{\text{housing}} + \Delta p_{\text{element}} \cdot \frac{\text{viscosity (mm}^2/\text{s)}}{30 \text{ mm}^2/\text{s}}$$

$\Delta p_{\text{housing}}$ = see point 5.1.

$\Delta p_{\text{element}}$ = element pressure drop at flow rate Q/n and viscosity = 30 mm²/s from graphs in 5.2

Example

System data:

= 150 l/min; MDF 240 with BN3HC element (20µm), Viscosity = 68 mm²/s

⇒ $\Delta p_{\text{housing}}$ = 0.16 bar at 150 l/min

$$\Delta p_{\text{element}} = 0.5 \cdot \frac{68 \text{ mm}^2/\text{s}}{30 \text{ mm}^2/\text{s}} = 1.13 \text{ bar}$$

$$\Delta p_{\text{total}} = \underline{\underline{1.29 \text{ bar}}}$$

6. DIMENSIONS

6.1. MDF

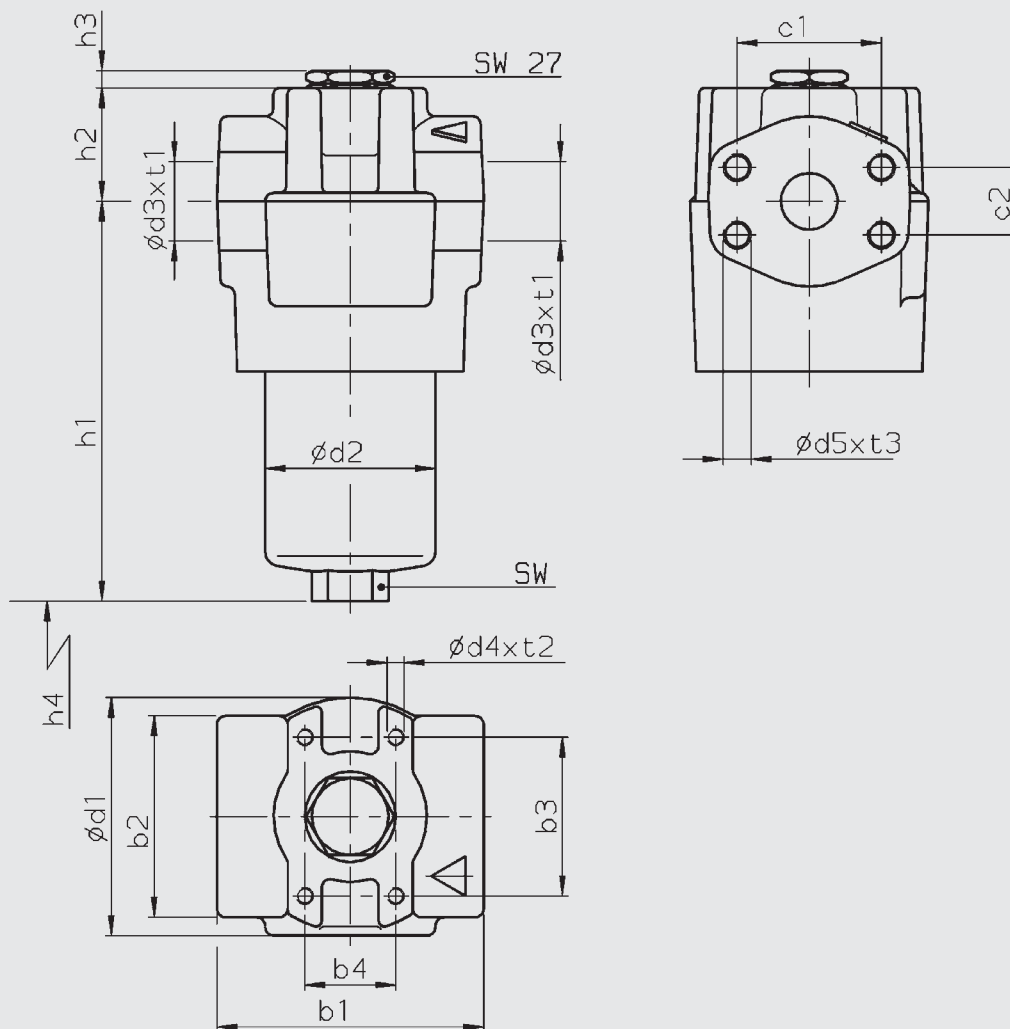

Type	b1	b2	b3	b4	c1	c2	d1	d2	d3	d4	d5	h1	h2	h3	h4	SW	t1	t2	t3	Weight with element [kg]	Volume of pressure chamber [l]
30 (G)	71	55	45	30	-	-	69	45	G ½ - G ¾	M5	-	133	38	6	75	19	14	6	-	2.3	0.1
30 (F)	70	55	45	30	38.1	17.5	69	45	SAE DN 13	M5	M8	133	38	6	75	19	-	6	12	2.3	0.1
60 (G)	90	71	56	32	-	-	86	59	G ¾ - G 1	M6	-	138	40	6	85	27	17	9	-	4.1	0.18
60 (F)	89	71	56	32	47.6	22.2	86	59	SAE DN 20	M6	M10	138	40	6	85	27	-	9	15	4.1	0.18
110 (G)	90	71	56	32	-	-	86	59	G ¾ - G 1	M6	-	206	40	6	85	27	17	9	-	4.6	0.32
110 (F)	89	71	56	32	47.6	22.2	86	59	SAE DN 20	M6	M10	206	40	6	85	27	-	9	15	4.6	0.32
160 (G)	133	95	85	35	-	-	119	84	G 1¼ - G 1½	M10	-	187	47	6	105	32	21	14	-	9.6	0.55
160 (F)	133	95	85	35	58.7	30.2	119	84	SAE DN 32	M10	M10	187	47	6	105	32	-	14	15	9.6	0.55
240 (G)	133	95	85	35	-	-	119	84	G 1¼ - G 1½	M10	-	246	47	6	105	32	21	14	-	10.5	0.79
240 (F)	133	95	85	35	58.7	30.2	119	84	SAE DN 32	M10	M10	246	47	6	105	32	-	14	15	10.5	0.79

G = threaded port F = flanged port

Note

The information in this brochure relates to the operating conditions and applications described. For applications or operating conditions not described, please contact the relevant technical department. Subject to technical modifications.