



Pressure Filter DF

Flow rates up to 680 l/min

Pressure range up to 420 bar

Material: Cast Iron - Steel

1. TECHNICAL SPECIFICATIONS

1.1 FILTER HOUSING

Construction

The filter housings are designed in accordance with international regulations. The filters consist of a filter head with a screw-on filter bowl.

Up to size 660 a one-piece bowl is standard. Size 660 is available either with a one-piece or a two-piece bowl. For size 990 and above, the filters are only available with the two-piece bowl. Standard equipment:

- Port for clogging indicator in the filter head
- Either threaded or flange port (for size 330 and above)
- Oil drain plug with pressure relief (for size 330 and above)

1.2 FILTER ELEMENTS

Original HYDAC filter elements guarantee reliable function and protect hydraulic components and systems which are sensitive to contamination from wear and tear. Performance and quality tests in accordance with international standards guarantee reliable operation of the filter.

Hydac filters are validated and their quality is continuously monitored according to the following standards.

- ISO 2941: Verification of collapse / burst resistance
- ISO 2942: Verification of fabrication integrity and determination of first bubble point test
- ISO 2943: Verification of material compatibility with fluids
- ISO 3724: Verification of flow fatigue characteristics
- ISO 3968: Evaluation of differential pressure versus flow characteristics
- ISO 16889: Multi-pass method for evaluating filtration performance of a filter element

In addition to guaranteeing retention and flow rate characteristics, the filter elements have excellent structural stability. The careful construction and mechanically stable support of the filter media guarantee above-average beta value stability and flow fatigue characteristics of the filter elements.

The filter elements are available with the following collapse/burst stability values:

Betamicon®(BN3HC):	25 bar
Betamicon®(BH3HC):	210 bar
Wire mesh (W):	30 bar
Stainless steel fibre (V):	210 bar

1.3 SEALS

Perbunan (=NBR)

1.4 SPECIAL MODELS AND ACCESSORIES

- Seals in FPM, EPDM
- Test and inspection certificates
- Bypass valve
- Oil drain plug up to size 280

1.5 SPARE PARTS

See Original Spare Parts List and Maintenance Instructions.

1.6 COMPATIBILITY WITH OPERATING FLUIDS TO DIN ISO 2943:

- Hydraulic oils H to HLPD to DIN 51524
- Lubrication oils to DIN 51517, APJ, ACEA, DIN 51515, ISO 6743
- Compressor oils to DIN 51506
- Rapidly biodegradable operating fluids to VDMA 24568 HETG, HEES, HEPG
- Non-flam operating fluids HFC and HFD
- Operating fluids with high water content (> 50% water content) on request

For further details on filter elements:

Brochure no.: E 7.200../..

1.7 CERTIFICATES AND APPROVALS

- Test certificate 2.2
- Manufacturer's certificate O and M to DIN 55350, Part 18
- Other certificates on request

1.8 WARNING

- Filter housing must be earthed.
- When using electrical clogging indicators, before removing the clogging indicator connector, the electrical power supply to the system must be switched off.

2. GENERAL

Mounting

Inline filter

Temperature range

-30 °C to +100 °C
(-30 °C to -10 °C: $p_{max} = 210 \text{ bar}$)

Pressure setting of the clogging indicator

$\Delta p_a = 5 \text{ bar}$ -0.5 bar

Other pressure settings on request

Cracking pressure of bypass valve

$\Delta p_o = 6 \text{ bar}$ +0.6 bar

Other cracking pressures on request

Circuit diagram for hydraulic systems

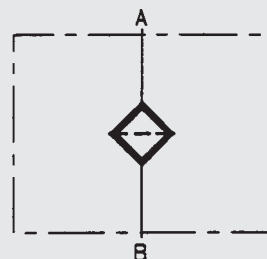

3. MODEL CODE (also order example)

3.1 COMPLETE FILTER

DF BN/HC 60 G 10 D 1.X /-L24

Filter type _____

DF

Filter material of element _____

BN/HC Betamicron® (BN3HC)
 BH/HC Betamicron® (BH3HC)
 W Stainless steel wire mesh
 V Stainless steel fibre

Size of filter or element _____

DF: 30/ 60/ 110/ 140/ 160/ 240/ 280/ 330/
 500/ 660/ 990/ 1320

Type of port _____

G Threaded port
 F Flange port

Filtration rating in µm _____

BN3HC, BH3HC, V: 3, 5, 10, 20
 W: 25, 50, 100, 200

Type of clogging indicator _____

Y plastic blanking plug in indicator port
 A steel blanking plug in indicator port
 B visual indicator
 C electrical indicator
 D combined visual/electrical indicator

for other clogging indicators,
 see brochure no. E 7.050../..

Type code _____

1 version with 1-piece bowl
 2 version with 2-piece bowl (size 660 and above)

Modification number _____

X the latest version is always supplied

Supplementary details _____

B. bypass valve cracking pressure, B6 = 6 bar (no details = without bypass)
 L... light with corresponding voltage (24V, 48V, 110V, 220V) } only on clogging
 LED 2 light-emitting diodes up to 24 volt } indicators type D
 SO 184 pressure release / oil drain plug (from size 330 and above)
 V FPM seals, filter suitable for rapidly biodegradable oils and phosphate ester (HFD-R)
 W suitable for oil-water emulsions HFA, HFC
 (only necessary when using a clogging indicator or V or W elements)

3.2 REPLACEMENT ELEMENT

0060 D 010 BN3HC /-V

Size _____

0030, 0060, 0110, 0140, 0160, 0240,
 0280, 0330, 0500, 0660, 0990, 1320

Type _____

D

Filtration rating in µm _____

BN3HC, BH3HC, V: 3, 5, 10, 20
 W: 25, 50, 100, 200

Filter material _____

BN3HC, BH3HC, V, W

Supplementary details _____

V = FPM seals, element suitable for rapidly biodegradable oils and phosphate ester (HFD-R)
 W = suitable for oil-water emulsions HFA/HFC
 (only necessary for V and W elements)

4. FILTER CALCULATION/ SIZING

The total pressure drop of a filter at a certain flow rate is the sum of the housing Δp and the element Δp . The pressure drop can either be determined with the aid of our HFS Filter Sizing Program, which is available free of charge, or by using the following graphs.

NEW: Sizing online at www.hydac.com (please click on the following buttons: Products - Filters - Electronic catalogue - Filter sizing HFS)

4.1 Δp -Q HOUSING GRAPHS TO ISO 3968

The housing graphs apply to mineral oil with a density of 0.86 kg/dm^3 and a kinematic viscosity of $30 \text{ mm}^2/\text{s}$ for the largest possible width per size. In this case, the differential pressure changes proportionally to the density.

DF 30

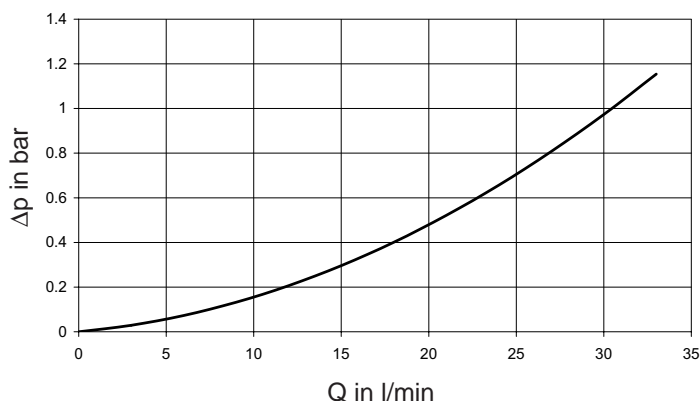

DF 60 / 110 / 140

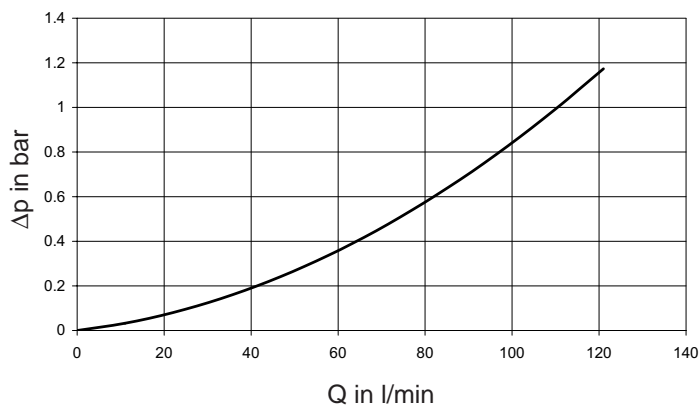

DF 160 / 240 / 280

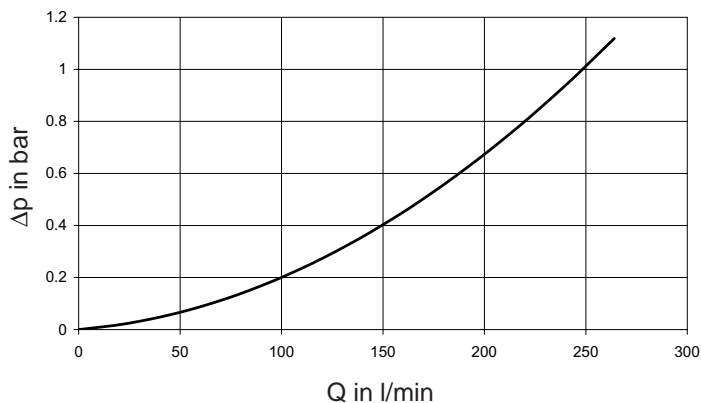

DF 330 / 500 / 660 / 990 / 1320 G

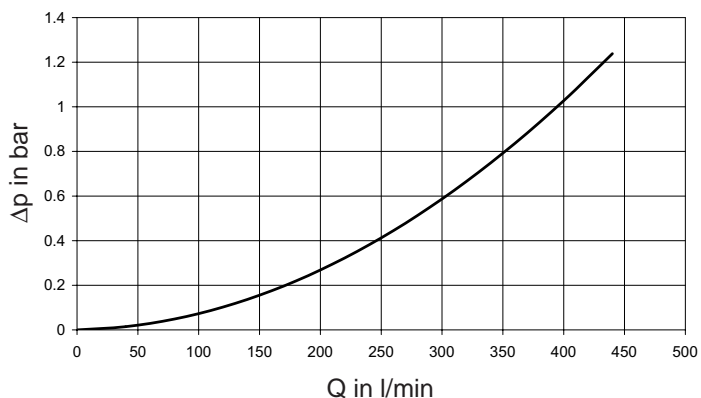

DF 330 / 500 / 660 / 990 / 1320 F

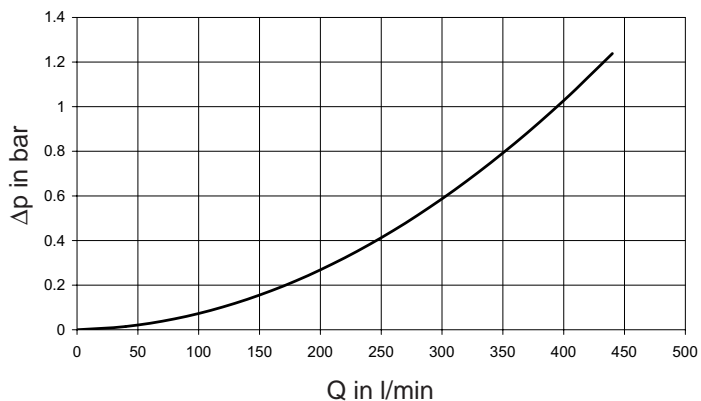

4.2 GRADIENT COEFFICIENT FOR FILTER ELEMENTS

Size	BH3HC				BN3HC				V				W
	3μm	5μm	10μm	20μm	3μm	5μm	10μm	20μm	3μm	5μm	10μm	20μm	
0030	0.08733	0.05233	0.03500	0.02073	0.05416	0.04900	0.03000	0.02000	0.01844	0.01350	0.00750	0.00364	0.00303
0060	0.04800	0.02900	0.01960	0.01455	0.02600	0.01750	0.01317	0.00945	0.01600	0.00933	0.00540	0.00330	0.00076
0110	0.02400	0.01209	0.00938	0.00727	0.01400	0.00973	0.00764	0.00545	0.00824	0.00555	0.00332	0.00216	0.00041
0140	0.02000	0.01207	0.00813	0.00616	0.01200	0.00700	0.00450	0.00367	0.00583	0.00476	0.00314	0.00229	0.00032
0160	0.01429	0.00906	0.00643	0.00473	0.01188	0.00690	0.00440	0.00350	0.00458	0.00323	0.00225	0.00144	0.00028
0240	0.00900	0.00596	0.00444	0.00333	0.00842	0.00529	0.00375	0.00318	0.00308	0.00250	0.00170	0.00133	0.00019
0280	0.00487	0.00293	0.00196	0.00150	0.00446	0.00271	0.00186	0.00143	0.00229	0.00170	0.00177	0.00075	0.00016
0330	0.00700	0.00421	0.00312	0.00218	0.00485	0.00361	0.00297	0.00209	0.00220	0.00177	0.00118	0.00078	0.00014
0500	0.00361	0.00226	0.00160	0.00128	0.00300	0.00200	0.00149	0.00116	0.00174	0.00118	0.00080	0.00051	0.00009
0660	0.00279	0.00167	0.00121	0.00097	0.00212	0.00156	0.00113	0.00088	0.00114	0.00091	0.00062	0.00039	0.00007
0990	0.00185	0.00111	0.00081	0.00065	0.00140	0.00104	0.00075	0.00059	0.00078	0.00062	0.00041	0.00027	0.00005
1320	0.00140	0.00083	0.00060	0.00048	0.00106	0.00078	0.00056	0.00044	0.00059	0.00047	0.00032	0.00021	0.00003

5. DIMENSIONS

5.1 DF

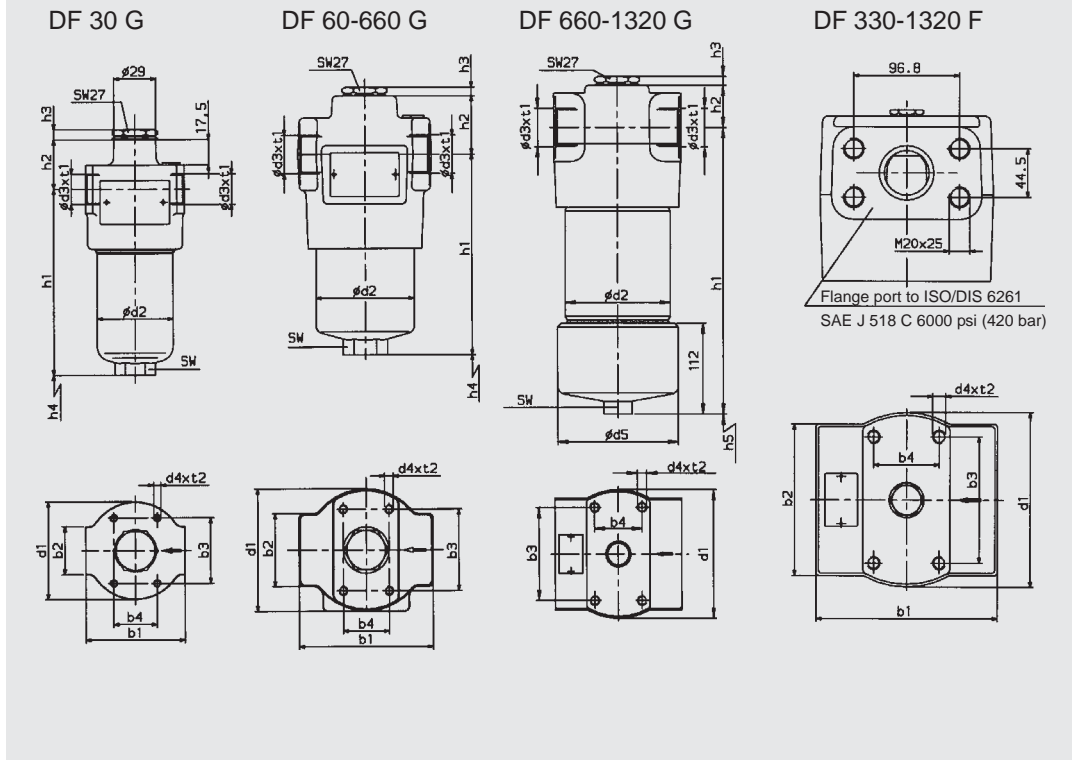

Type	b1	b2	b3	b4	d1	d2	d3	d4	d5	h1	h1 DF..2.x	h2	h3	h4	h5 DF..2.x	SW	t1	t2	Weight in kg	Volume of pressure chamber in l
30 (G)	68	33	45	30	67	52	G ½	M5	-	127.5	-	34	7	75	-	24	15	6	1.9	0.13
60 (G)										137.5	-								4.1	0.20
110 (G)	93	50	56	32	84	68	G ¾	M6	-	205.0	-	40	6	85	-	27	17	9	5.0	0.33
140 (G)										248.5	-								5.6	0.40
160 (G)										193.5	-								9.7	0.60
240 (G)	128	65	85	35	117	95	G 1¼	M10	-	253.5	-	47	6	105	-	32	21	14	11.1	0.80
280 (G)										435.5	-								15.3	1.6
330 (G)							G 1½			255.5	-								24.6	1.5
330 (F)							SAE DN 50			255.5	-									
500 (G)							G 1½			348.5	-								28.7	2.3
500 (F)							SAE DN 50			348.5	-									
660 (G)	160	138	115	60	159	130	G 1½	M12	152	426.0	420.0	52	6	115	350	36	23	17	32.0 (1.x)	3.00
660 (F)							SAE DN 50			426.0	420.0				350				35.0 (2.x)	
990 (G)							G 1½			-	576.0				500				41.5	4.20
990 (F)							SAE DN 50			-	576.0				500					
1320 (G)							G 1½			-	742.0				670				49.2	5.60
1320 (F)							SAE DN 50			-	742.0				670					

G = threaded port
F = flange port

6. NOTE

The information in this brochure relates to the operating conditions and applications described.

For applications or operating conditions not described, please contact the relevant technical department.

Subject to technical modifications.