

HYDAC

INTERNATIONAL

Inline Filters NF

Flow rates up to 3,500 l/min

Pressure range 25 bar

Material: Aluminium /
Aluminium-Cast Iron

NF filters are designed for inline mounting and as tank-top mounted return line filters.

These filters can also be used on filling, flushing and off-line units.

VA



1. TECHNICAL DESCRIPTION

1.1. FILTER HOUSING

Construction

The filter consists of a filter housing and an easily removable cover plate with central thread.

1.2. FILTER ELEMENTS

Hydac filter elements fulfil all ISO test criteria.

Reliable filter operation is only guaranteed for original Hydac filter elements.

The filter elements are also suitable for dynamic conditions due to their high pressure stability; max permissible Δp across the element:

Betamicon® (BN3HC)	: 25 bar
Paper (P/HC)	: 10 bar
Wire mesh (W/HC)	: 30 bar
Stainless steel fibre (V)	: 30 bar
Betamicon®/Aquamicron® (BN/AM)	: 10 bar
Aquamicron® (AM)	: 10 bar

Fluid compatibility

Suitable for mineral oils, lubrication oils, non-flam fluids, synthetic and rapidly biodegradable fluids. For use with water, please contact our sales/technical department.

For further details on filter elements, please see **brochure, no.: E 7.200../..**

1.3. CLOGGING INDICATORS

VR 2 D. 0 / -L220

Type of indicator

VR return line indicator (only in version 1.0)
VM differential pressure indicator (only in version 2.0 and 3.0)

Pressure setting

2 2 bar
5 5 bar

Indicator type code

B. = visual
C. = electrical
D. = visual/electrical

Modification number

0 = the latest version is always supplied

Supplementary details

-V Viton
-Lxx voltage details for type "D"

Please note:

The clogging indicator must not be screwed into the cover plate.

For further details on clogging indicators, please see **brochure, no. E 7.050../..**

1.4. SEALS

Perbunan (= NBR) or Viton (= FPM for HFD oils).

1.5. SPECIAL MODELS AND ACCESSORIES

– Mounting bracket for size 1310/2610

1.6. SPARE PARTS

Please see Spare Parts and Maintenance Instructions – brochure.

2. GENERAL

Mounting

Tank-top mounted return line filter or inline filter

Temperature range

-10 °C to +100 °C

Pressure setting of the differential pressure clogging indicator

$\Delta p_a = 2 \text{ bar} -10 \%$

Other pressure settings on request!

Opening pressure of the bypass valve

$\Delta p_o = 3 \text{ bar} +0.5 \text{ bar}$
optionally 6 bar

Other opening pressures on request!

3. MODEL CODE

(also order example)

3.1. COMPLETE FILTER

NF BN/HC 2610 D P 10 D 1 . X /-L24

Filter type

Filter material of element

BN/HC Betamicon® (BN3HC)
 AM Aquamicon®
 BN/AM Betamicon®/Aquamicon®
 P/HC Paper
 W/HC Stainless steel wire mesh
 V Stainless steel fibre

Housing material / Size

Al/Al-GGG 1310, 1350, 2610, 2650, 5210, 7810, 10410

Operating pressure

D = 25 bar

Type and size of port

Type	Port	Filter size						
		1310	1350	2610	2650	5210	7810	10410
L	SAE DN 50		●		●			
M	SAE DN 65		●		●			
N	SAE DN 80		●		●			
P	SAE DN 100	●	●	●	●	●	●	●

Filtration rating in µm

BN3HC, V : 3, 5, 10, 20
 BN/AM : 3, 10
 P/HC : 10, 20
 W/HC : 25, 50, 100, 200
 AM : 40

Type of clogging indicator

A without clogging indicator, with blanking plug
 B with visual clogging indicator (only for tank-top mounted return line filters)
 BM with visual clogging indicator, manual re-set (all types)
 C with electrical clogging indicator
 D with visual and electrical clogging indicator
 LE visual-mechanical/electrical clogging indicator with 100% switching contact
 LZ visual-mechanical/electrical clogging indicator with 75% and 100% switching contact

for other clogging indicators see brochure no. E 7.050../..

Type code

- 1 Tank-top return line filter – return line indicator
 – inlet flange horizontal at top, outlet vertical from size 5210 horizontal
 – tank seal supplied
- 2 Inline filter – differential pressure indicator
 – inlet flange horizontal at bottom, outlet vertical, from size 5210, horizontal
only for size 1350/2650:
 – differential pressure indicator
 – inlet and outlet horizontal and opposite
- 3 Inline filter – differential pressure indicator
 – inlet flange horizontal at top, outlet vertical

Type code	Filter size						
	1310	1350	2610	2650	5210	7810	10410
1	●		●		●	●	
2	●	●	●	●	●	●	●
3	●		●				

Modification number

X the latest version is always supplied

Supplementary details

V FPM (Viton) seals, filter suitable for rapidly biodegradable oils and phosphate esters (HFD-R)

L... light with appropriate voltage (24V, 48V, 110V, 220V)

LED 2 light emitting diodes up to 24 volt

KB without bypass valve

B6 opening pressure of the bypass valve 6 bar

SB4 filling line with Ø 4 mm orifice

EM manual vent with shut-off valve

EP permanent vent via Minimesse hose

only on type D indicators

3.2. REPLACEMENT ELEMENT (also order example)

1300 R 010 BN3HC /-KB

Size
1300, 2600

Type
R

Filtration rating in μm
 BN3HC, V : 3, 5, 10, 20
 BN/AM : 3, 10
 P/HC : 10, 20
 W/HC : 25, 50, 100, 200
 AM : 40

Filter material
 BN3HC; V; BN/AM; P/HC; W/HC; AM

Supplementary details
 V = FPM (Viton) seals, filter suitable for rapidly biodegradable oils and phosphate esters (HFD-R)
 W = filter suitable for oil-water emulsions (HFA, HFC), NBR seals
 KB = without bypass valve
 B6 = opening pressure of the bypass valve 6 bar

4. FILTER SPECIFICATIONS

Filter type	Port	Element size	Number of elements	Weight (kg) with element
1310	SAE DN 100	1300 R...	1	21
	SAE DN 50			
1350	SAE DN 65	1300 R...	1	18
	SAE DN 80			
	SAE DN 100			
2610	SAE DN 100	2600 R...	1	30
	SAE DN 50			
2650	SAE DN 65	2600 R...	1	25
	SAE DN 80			
	SAE DN 100			
5210	SAE DN 100	2600 R...	2	104
7810	SAE DN 100	2600 R...	3	146
10410	SAE DN 100	2600 R...	4	198

5. FILTER CALCULATION / SIZING

The total pressure drop of a filter at a certain flow rate is the sum of the housing Δp and element Δp .

The pressure drop can be determined either with the aid of our Filter Sizing Program, which is available free of charge, or by using the following graphs.

It must be stressed that all of the technical documentation from HYDAC Filtrertechnik always states the pressure drop of the complete filter.

5.1. ΔP -Q HOUSING GRAPHS TO ISO 3968

The housing graphs apply to mineral oil with a density of 0.86 kg/dm^3 and a viscosity of $30 \text{ mm}^2/\text{s}$. In this case, the differential pressure changes proportionally to the density.

NF 1310/2610...1.0/2.0/3.0
NF 1350/2650...2.0

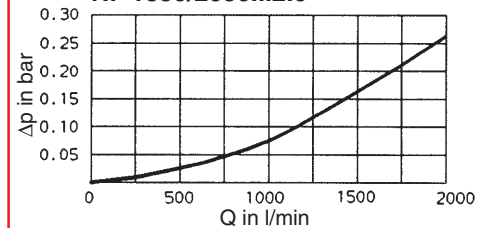

NF 5210...2.0

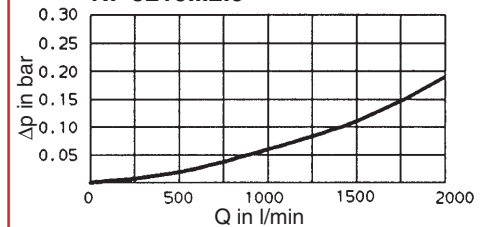

NF 7810...2.0

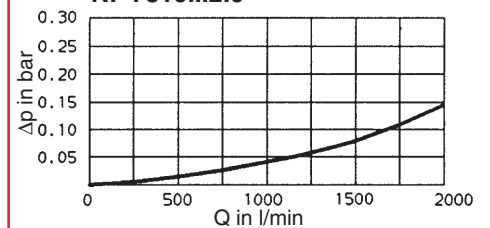

NF 10410...2.0

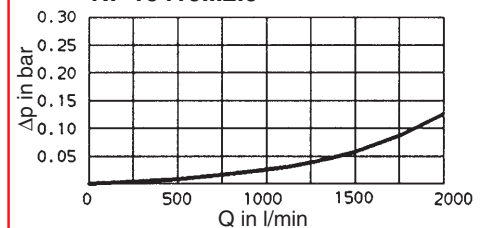

5.2. ΔP -Q GRAPHS
FILTER ELEMENTS

The element graphs apply to mineral oil with a kinematic viscosity of 30 mm²/s. The pressure drop changes proportionally to the change in viscosity (see Example 5.3.).

BN3HC

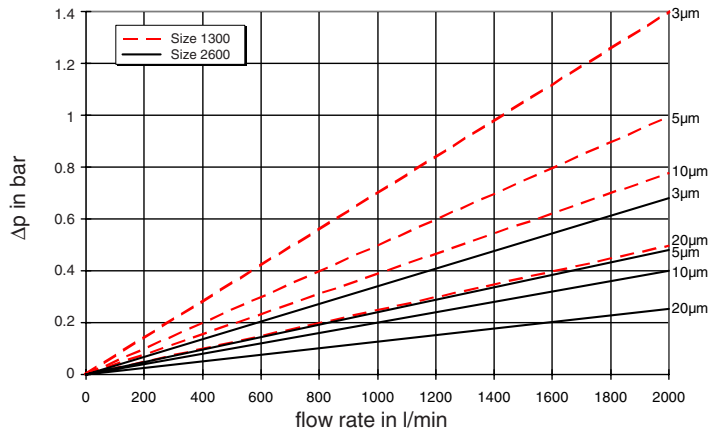

V

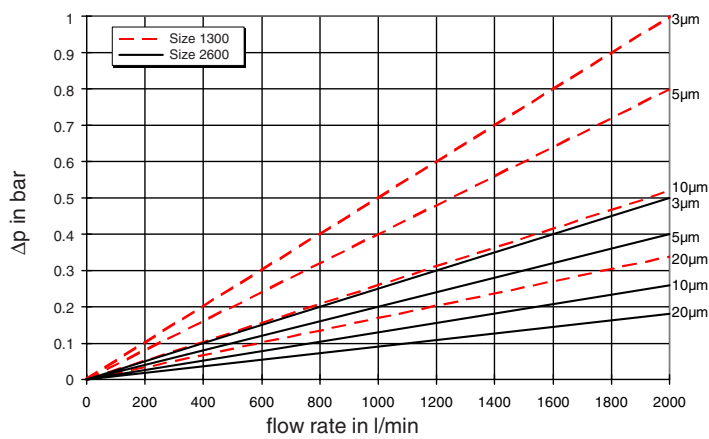

W/HC

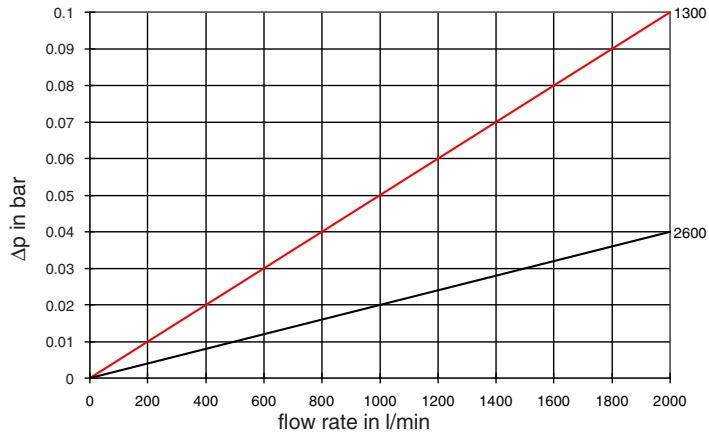

P/HC

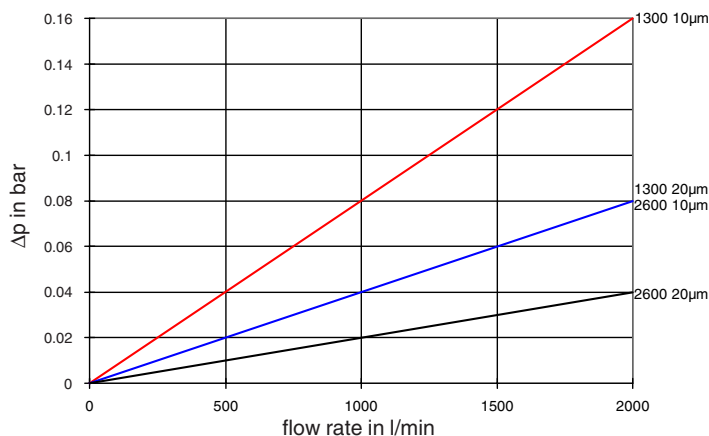

5.3. EXAMPLE

General

$$\Delta p_{\text{total}} = \Delta p_{\text{housing}} + \Delta p_{\text{element}} \times \frac{\text{viscosity (mm}^2/\text{s)}}{30 \text{ mm}^2/\text{s}}$$

$\Delta p_{\text{housing}}$ = to be determined in accordance with Point 5.1.

$\Delta p_{\text{element}}$ = element pressure drop at flow rate Q/n and viscosity = 30 mm²/s determined according to Point 5.2.

n = no. of elements in accordance with Point 4 Filtration specifications

Example

System parameters: NF 5210 with BN3HC element (10 μm)

Viscosity = 68 mm²/s

(ISO VG 68 at 40 °C);

Q = 1400 l/min; n = 2

$$\Rightarrow \frac{Q}{n} = \frac{1400}{2} = 700 \text{ l/min}$$

$$\Rightarrow \Delta p_{\text{housing}} = 0.10 \text{ bar (at Q)}$$

$$\Delta p_{\text{element}} = 0.15 \text{ (at Q/n)}$$

$$\Delta p_{\text{total}} = 0.10 \text{ bar} + 0.15 \times \frac{68 \text{ mm}^2/\text{s}}{30 \text{ mm}^2/\text{s}} = \underline{\underline{0.44 \text{ bar}}}$$

For ease of calculation, our Filter Sizing Program can be downloaded from our website www.hydac.com.

6. DIMENSIONS

6.1. NF 1310/2610...1.0

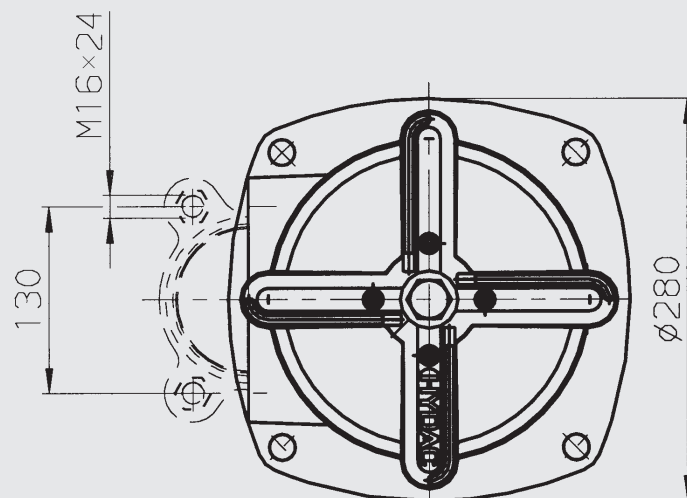
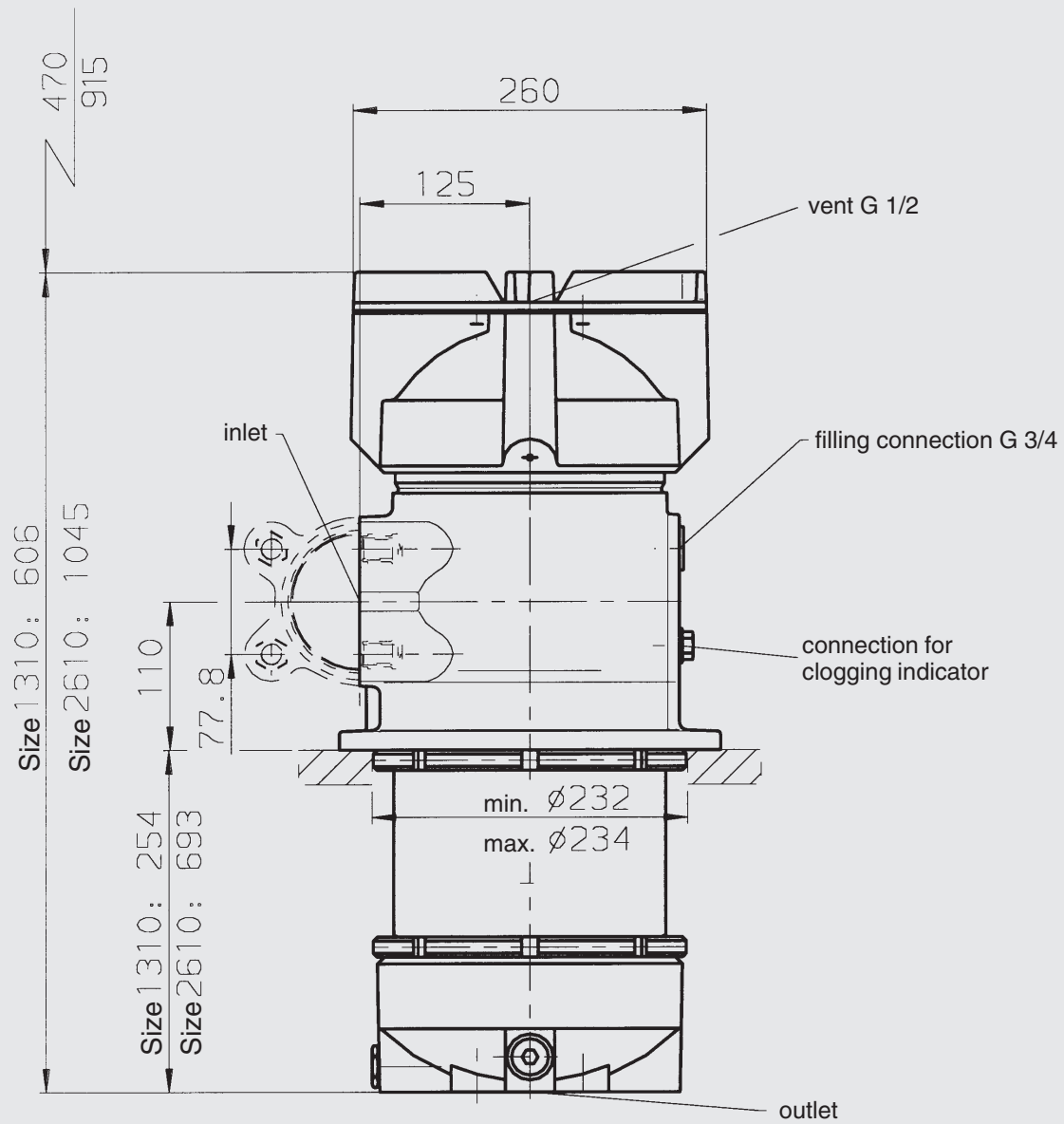

6.2. NF 1310/2610...2.0

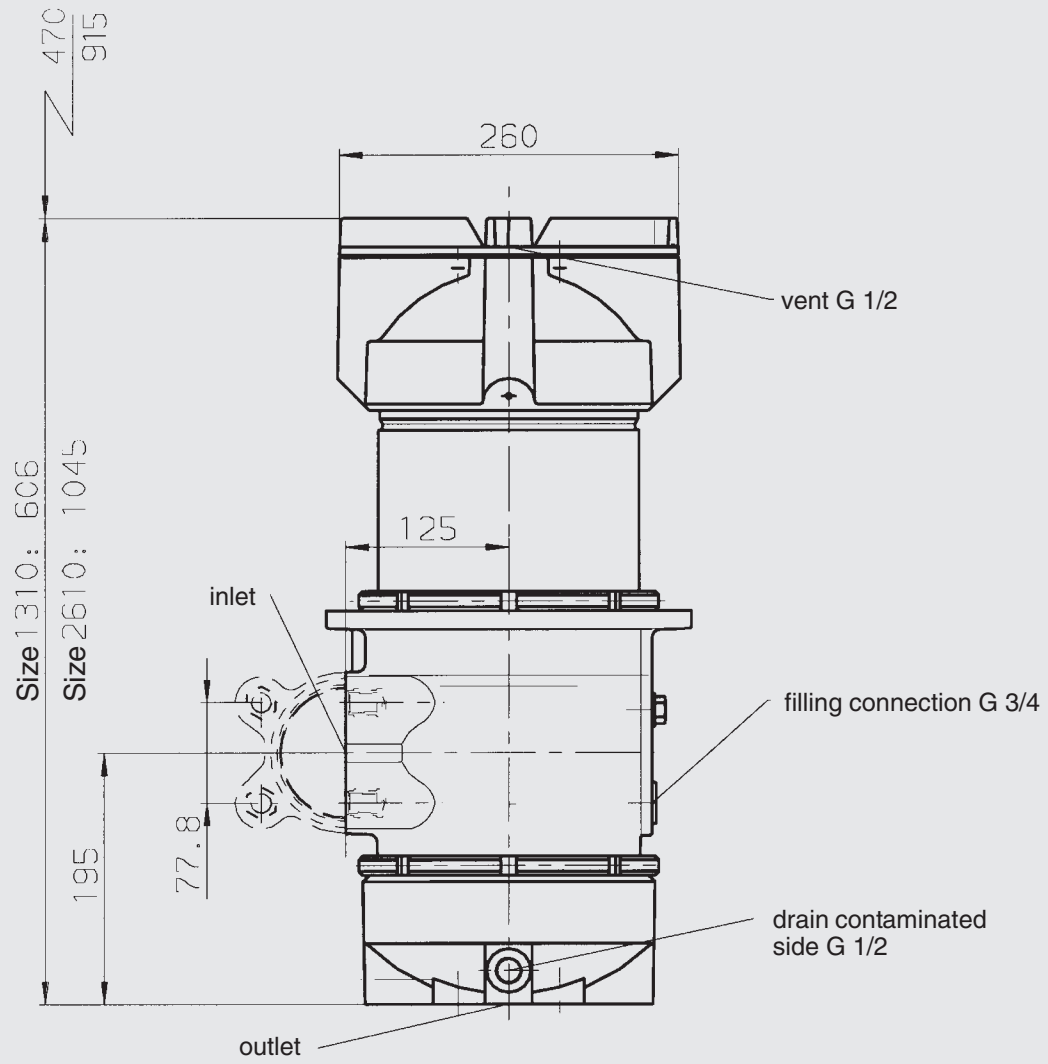

View from below

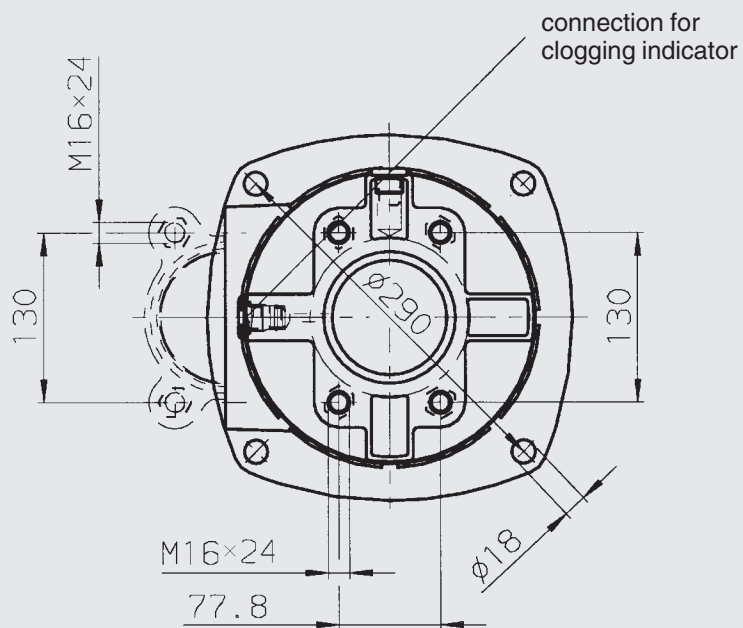

6.3. NF 1310/2610...3.0

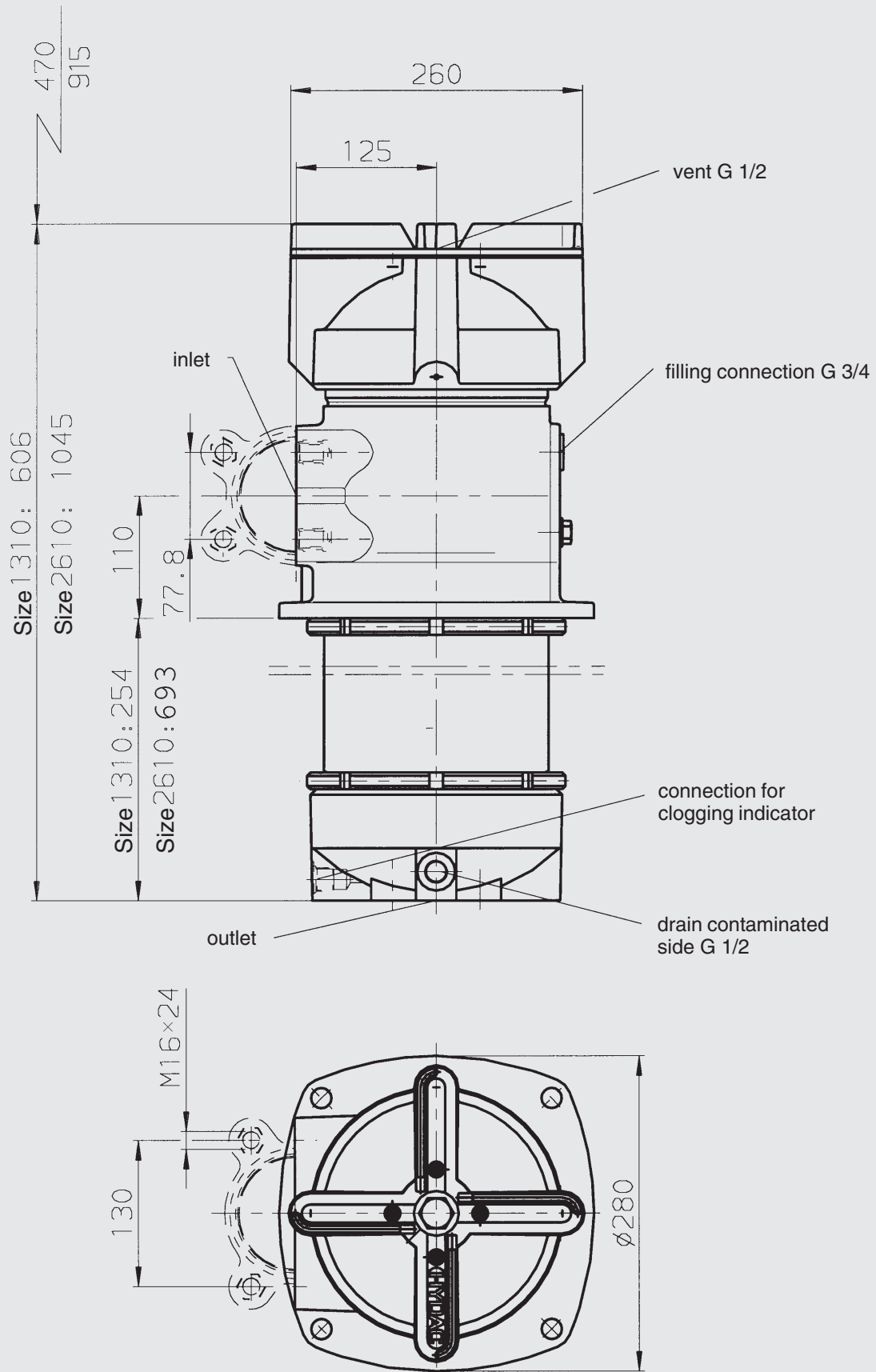

6.4. NF 1350

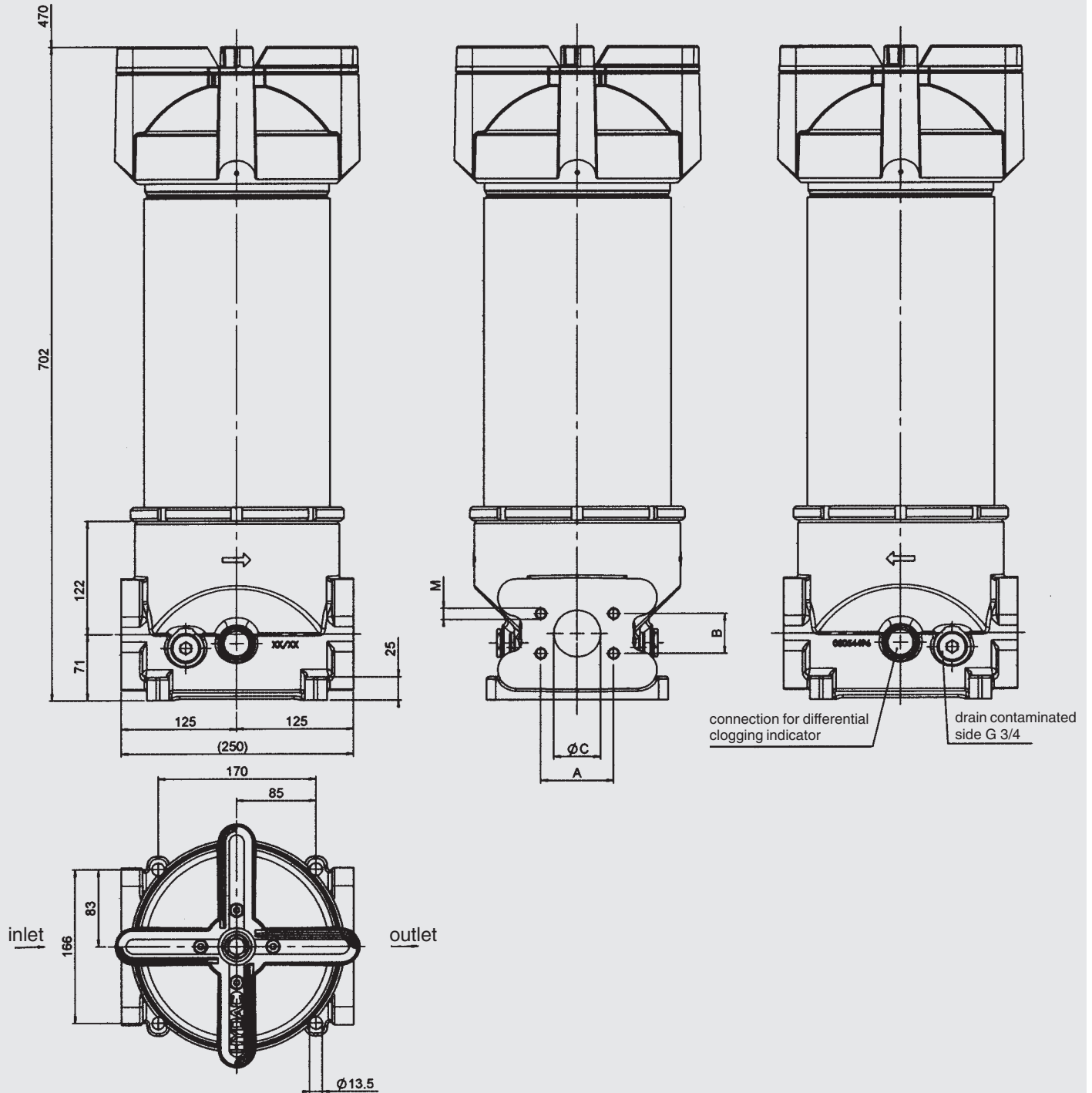

Port	A	B	ØC	M
SAE DN 50 / 2"	77.8	42.9	50	M 12x15
SAE DN 65 / 2 1/2"	88.9	50.8	65	M 12x15
SAE DN 80 / 3"	106.4	62.9	75	M 16x24
SAE DN 100 / 4"	130.2	77.8	100	M 16

6.5. NF 2650

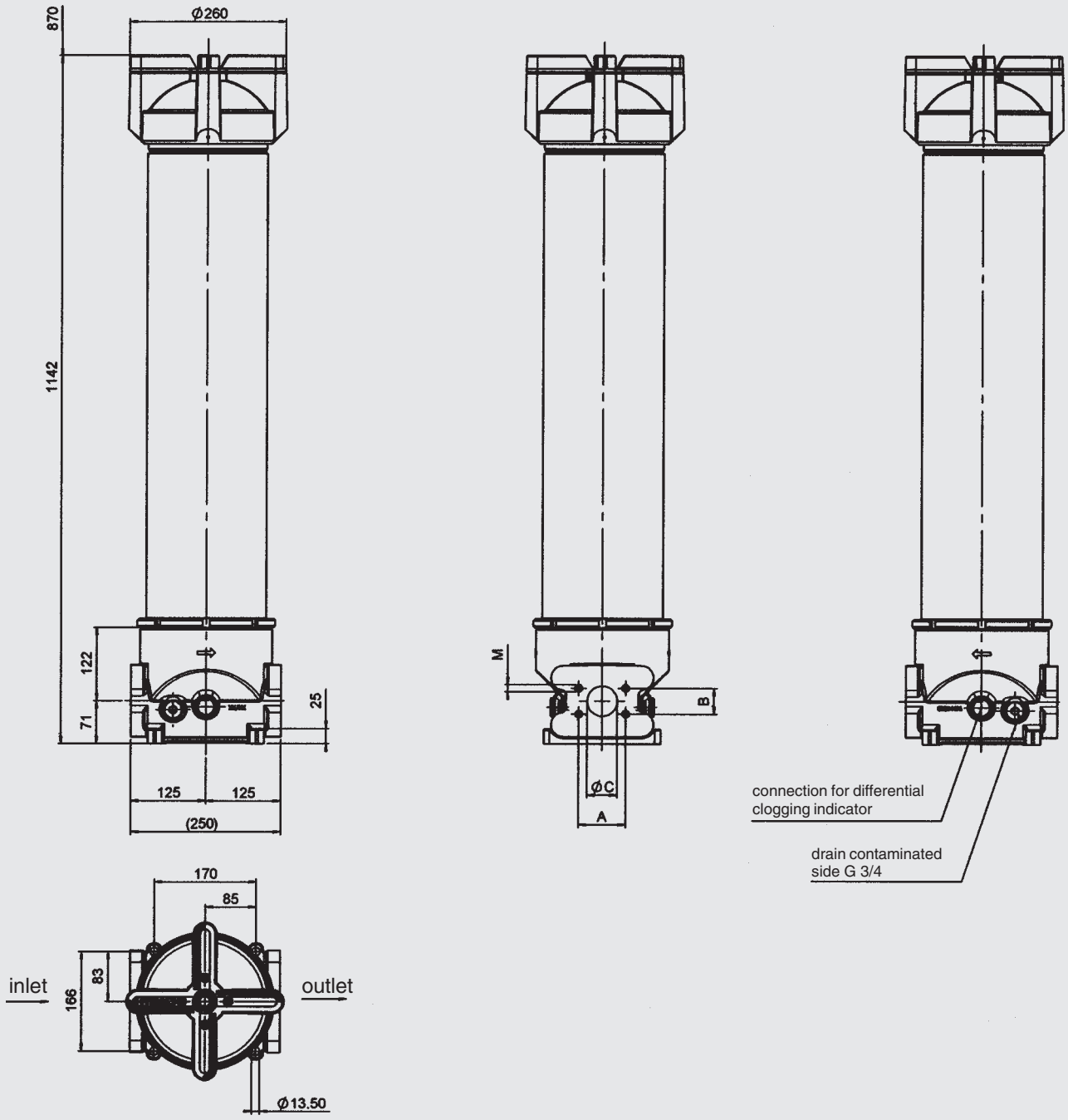

Port	A	B	ØC	M
SAE DN 50 / 2"	77.8	42.9	50	M 12x15
SAE DN 65 / 2 1/2"	88.9	50.8	65	M 12x15
SAE DN 80 / 3"	106.4	62.9	75	M 16x24
SAE DN 100 / 4"	130.2	77.8	100	M 16

6.6. NF 5210...1.0

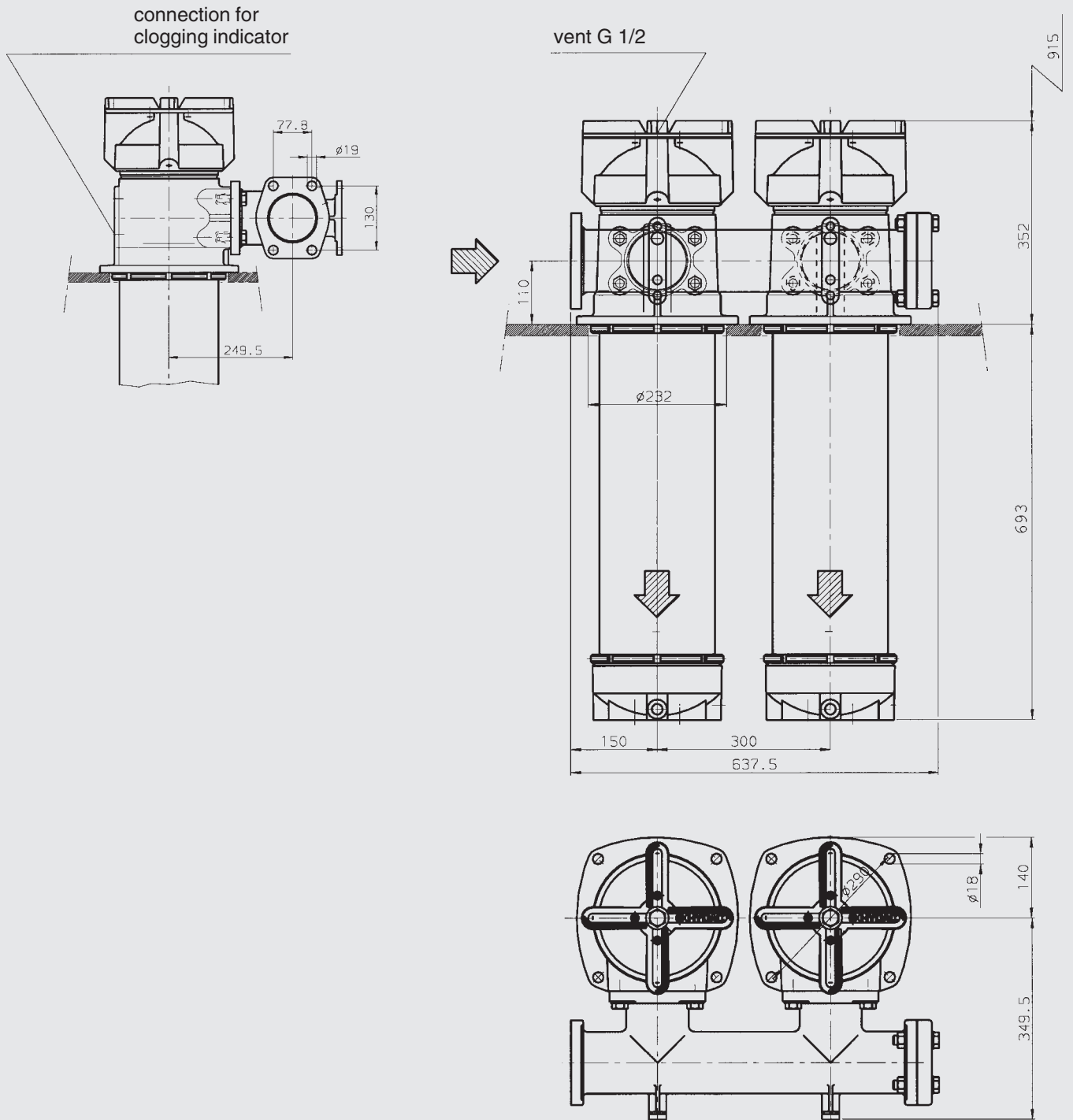

6.7. NF 5210...2.0

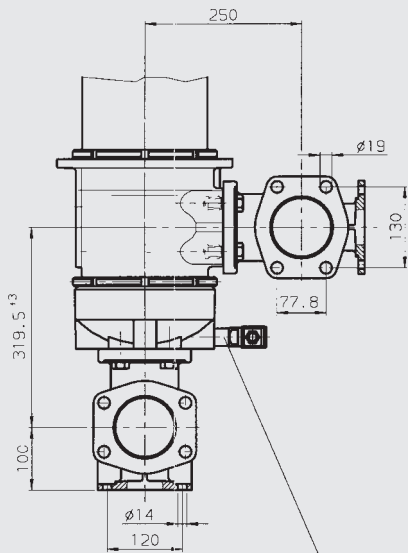

connection for
clogging indicator

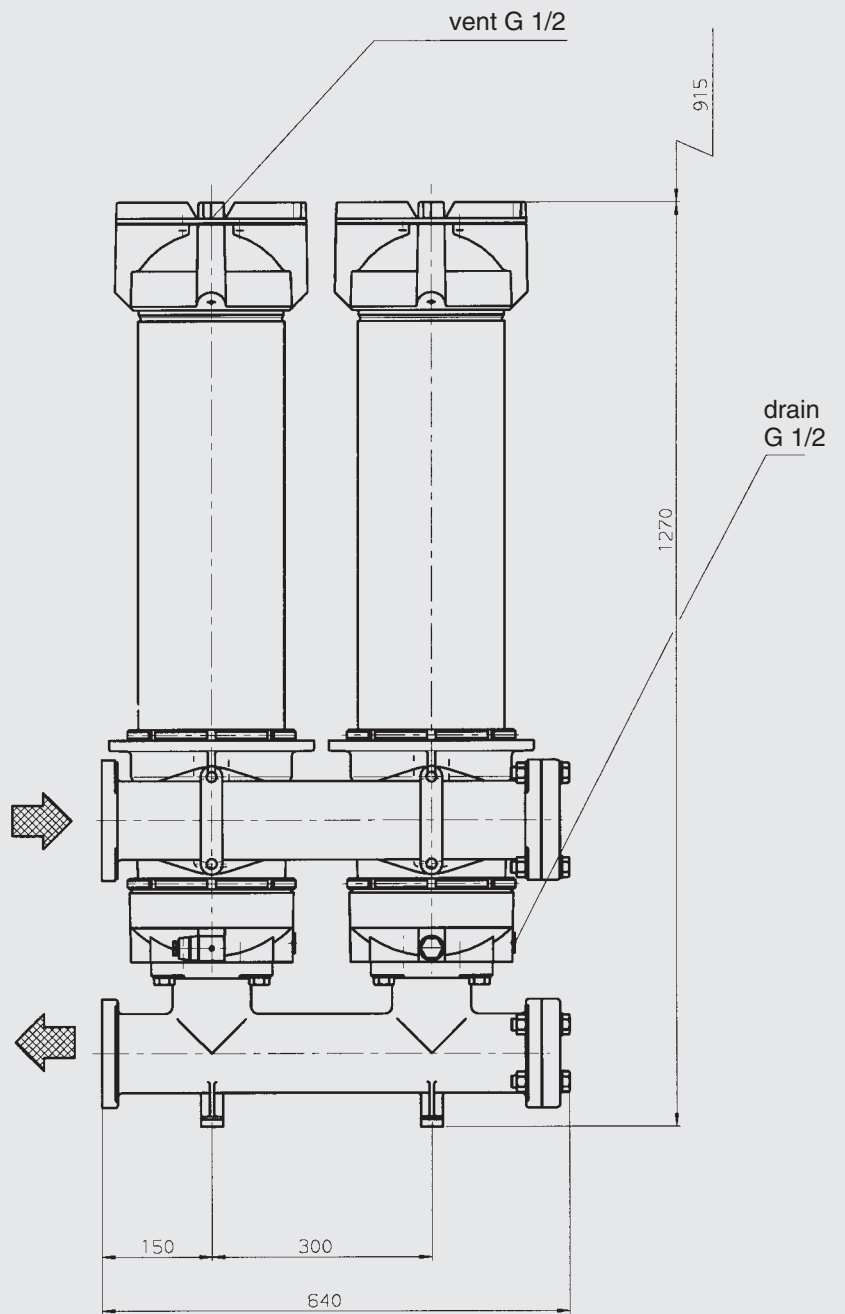
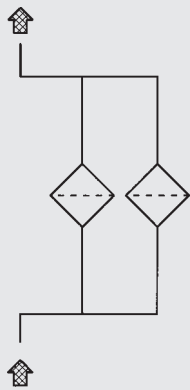

6.8. NF 7810...2.0

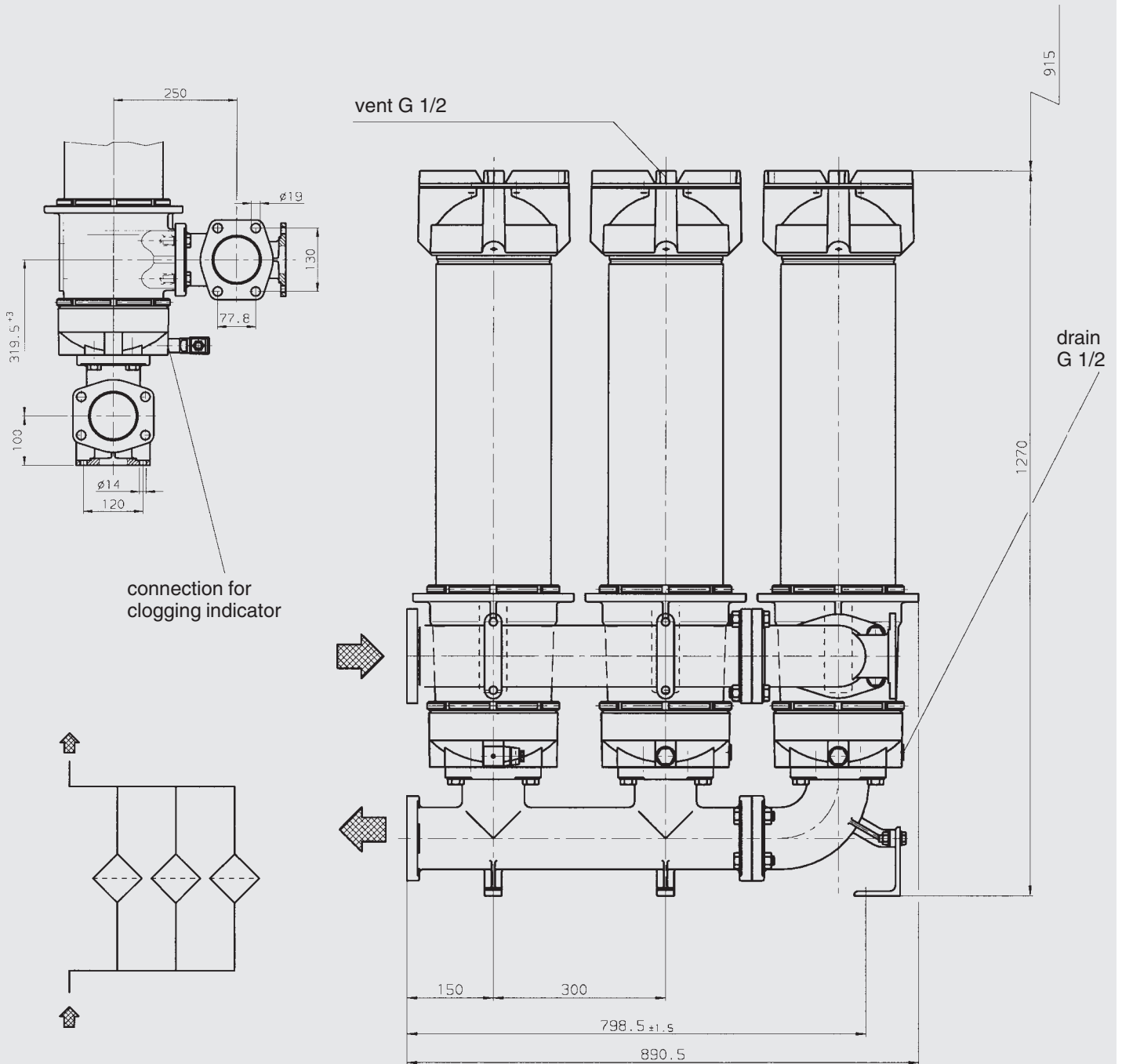

6.9. NF 10410...2.0

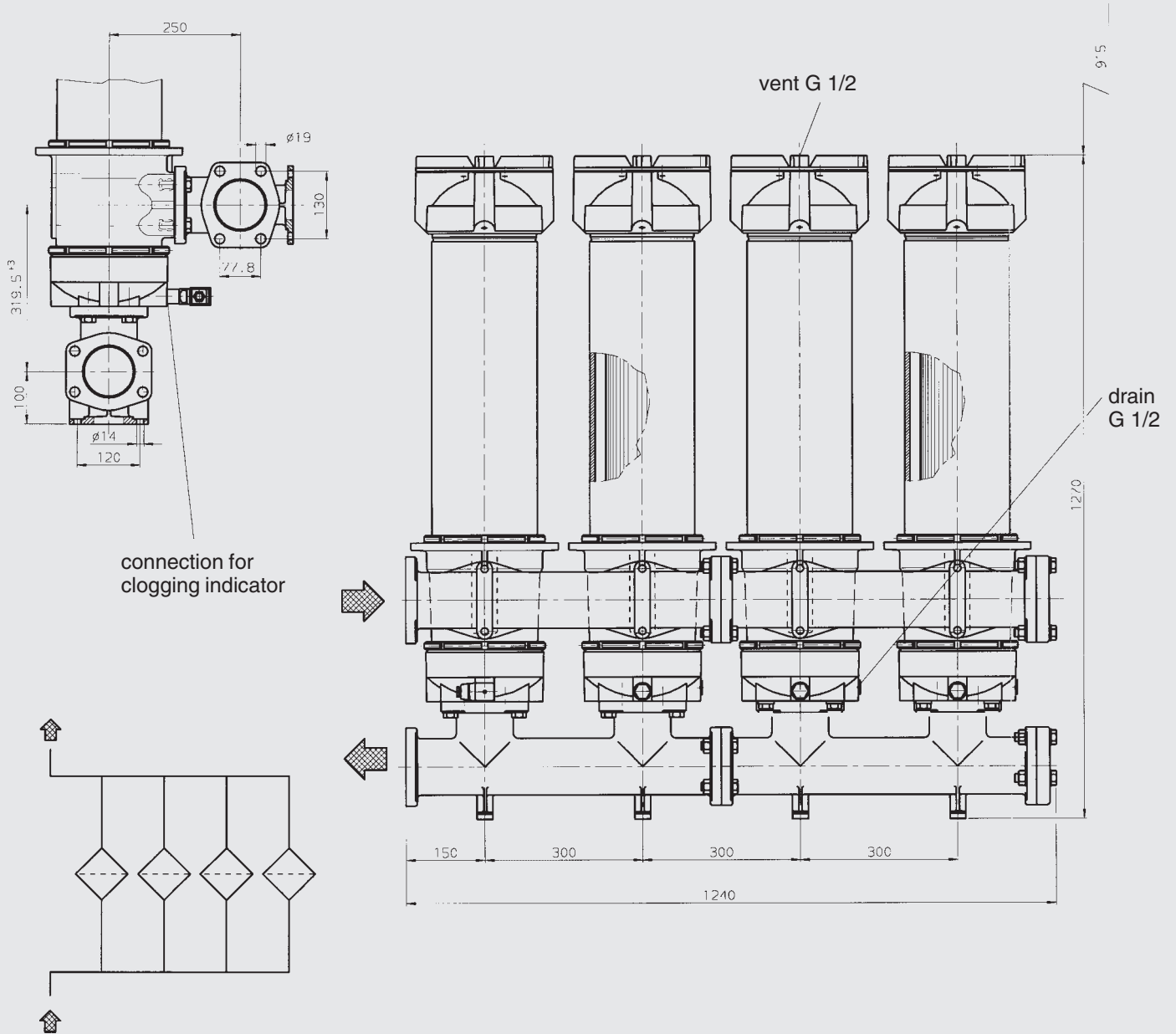

7. NOTE

The information in this brochure relates to the operating conditions and applications described. For applications or operating conditions not described, please contact the relevant technical department. Subject to technical modifications.

NOTES: