

HYDAC

INTERNATIONAL

Low Pressure Filter LPF

Flow rates up to 280 l/min

Pressure ranges up to 25 and 50 bar

Material: Aluminium / Steel

LPF low pressure filters offer the combined advantages of high performance filtration, high contamination retention capacity, long service life and economy.

The filters are particularly suited to applications in industrial hydraulics and in the mobile sector such as, for example:

- Pressure lines with up to 50 bar operating pressure
- Return lines with flow rate fluctuations and pressure peaks
- Feed lines of hydrostatic drives
- Off-line filtration
- Flushing circuits
- Alternative to high pressure spin-ons



VD

1. TECHNICAL DESCRIPTION

1.1. FILTER HOUSING

Construction

The low pressure filter consists of a filter head, a filter element and a filter bowl which is fixed to the filter head by means of a retaining nut.

1.2. FILTER ELEMENTS

Hydac filter elements fulfil all ISO test criteria.

Reliable filter operation is only guaranteed for original Hydac filter elements.

The filter elements are also suitable for dynamic conditions due to their high pressure stability; max permissible Δp across the element:

Betamicron® (BN3HC) : 25 bar
Betamicron® (BH3HC) : 210 bar
Wire mesh (W/HC) : 30 bar

Fluid compatibility

Suitable for mineral oils, lubrication oils, non-flam fluids, synthetic and rapidly biodegradable fluids. For use with water, please contact our sales/technical department.

For further details on filter elements, please see brochure, no.: **E 7.200../..**

1.3. CLOGGING INDICATORS

VM 5 D. 0 / -L220

Type of indicator

VM differential pressure indicator

Pressure setting

5 5 bar

Indicator type code

B. = visual
C. = electrical
D. = visual/electrical

Modification number

0 = the latest version is always supplied

Supplementary details

-V Viton
-Lxx voltage details for type "D"

For further details on clogging indicators, please see **brochure, no. E 7.050../..**

1.4. SEALS

Perbunan (= NBR) or Viton (= FPM for HFD oils).

1.5. SPECIAL MODELS AND ACCESSORIES

Please contact our sales/technical department.

1.6. SPARE PARTS

Please see Spare Parts List and Maintenance Instructions.

2. GENERAL

Mounting

Inline filter

Temperature range

-30 °C to +100 °C

Pressure setting of the clogging indicator

$\Delta p_a = 5 \text{ bar} -10 \%$

(optionally: 2 bar)

Other pressure settings on request

Cracking pressure of the bypass valve

$\Delta p_o = 6 \text{ bar} +0.5 \text{ bar}$

(optionally: 3 bar)

Other cracking pressures on request

3. MODEL CODE

(also order example)

3.1. COMPLETE FILTER

LPF BN/HC 280 D E 10 D 1 . X /-L24

Filter type _____

Filter material of element _____

BN/HC Betamicron® (BN3HC)
 BH/HC Betamicron® (BH3HC)
 W/HC Stainless steel wire mesh

Size / Housing material _____

160, 240, 280
 Head: Aluminium; Bowl: Steel; Retaining nut: Aluminium (25 bar) Steel (50 bar)

Operating pressure _____

D = 25 bar
 G = 50 bar | all sizes

Type and size of port _____

Type	Port	Filter size		
		160	240	280
E	G 1 1/4	●	●	●

Filtration rating in µm _____

BN3HC, BH3HC : 3, 5, 10, 20
 W/HC : 25, 50, 100, 200

Type of clogging indicator _____

A without clogging indicator,
 steel blanking plug in indicator port
 B with visual clogging indicator
 C with electrical clogging indicator
 D with visual and electrical clogging indicator

for other clogging indicators, see brochure no. E 7.050../..

Type code _____

1

Modification number _____

X the latest version is always supplied

Supplementary details _____

V FPM seals, filter suitable for rapidly biodegradable oils and phosphate esters (HFD-R)
 W filter suitable for oil-water emulsions (HFA, HFC) – (only necessary for W/HC!)
 L... light with appropriate voltage (24V, 48V, 110V, 220V)
 LED 2 light emitting diodes up to 24 volt
 B. bypass valve cracking pressure (B3 = 3 bar, B6 = 6 bar)

only for clogging indicator type D

3.2. REPLACEMENT ELEMENT

(also order example)

0280 D 010 BN3HC /-V

Size _____

0160, 0240, 0280

Type _____

D

Filtration rating in µm _____

BN3HC, BH3HC : 3, 5, 10, 20
 W/HC : 25, 50, 100, 200

Filter material _____

BN3HC, BH3HC, W/HC

Supplementary details _____

V = FPM seals, filter suitable for rapidly biodegradable oils and phosphate esters (HFD-R)
 W = NBR seals, filter suitable for oil-water emulsions (HFA, HFC)

4. FILTER SPECIFICATIONS

Filter type	Port	Element size	Number of elements	Weight [kg] with element
160	G 1¼	0160 D ...	1	2.3
240	G 1¼	0240 D ...	1	2.5
280	G 1¼	0280 D ...	1	3.4

5. FILTER CALCULATION / SIZING

The total pressure drop of a filter at a certain flow rate is the sum of the housing Δp and element Δp .

The pressure drop can either be determined with the aid of our HFS Filter Sizing Program, which is available free of charge, or by using the following graphs.

NEW: Sizing online at www.hydac.com (please click on the following buttons: Products - Filters - Electronic catalogue - Filter sizing HFS)

It must be stressed that all of the technical documentation from HYDAC Filtrertechnik always states the total housing pressure drop.

5.1. ΔP -Q DIAGRAMS TO ISO 3968

The housing graphs apply to mineral oil with a density of 0.86 kg/dm^3 and a kinematic viscosity of $30 \text{ mm}^2/\text{s}$. In this case, the differential pressure changes proportionally to the density.

Size 160 - 280

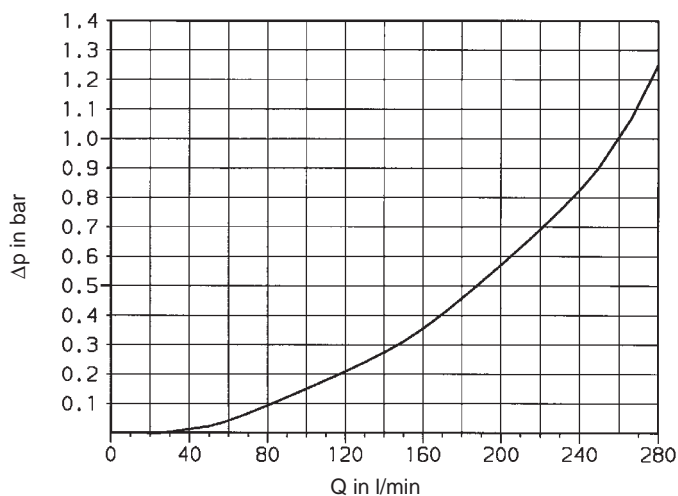

5.2. ΔP-Q GRAPHS – FILTER ELEMENTS

The element graphs apply to mineral oil with a kinematic viscosity of 30 mm²/s. The pressure drop changes proportionally to the change in viscosity (see Example 5.3.).

BN3HC

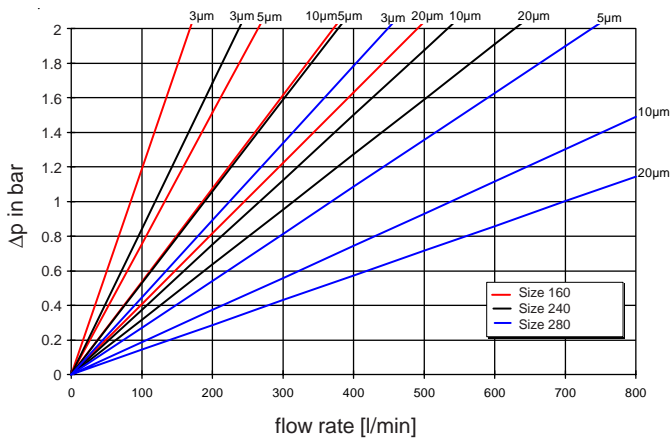

BH3HC

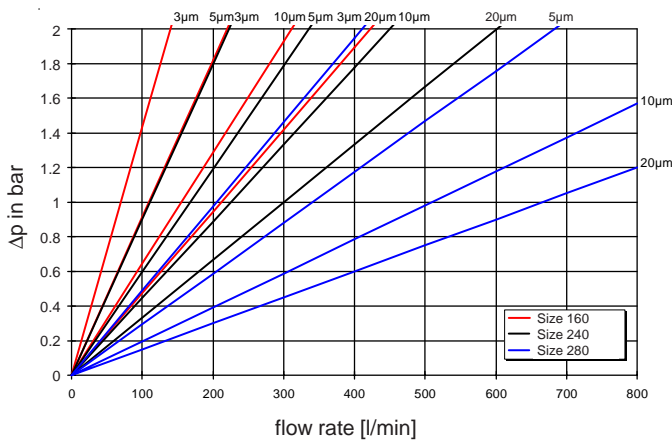

W/HC

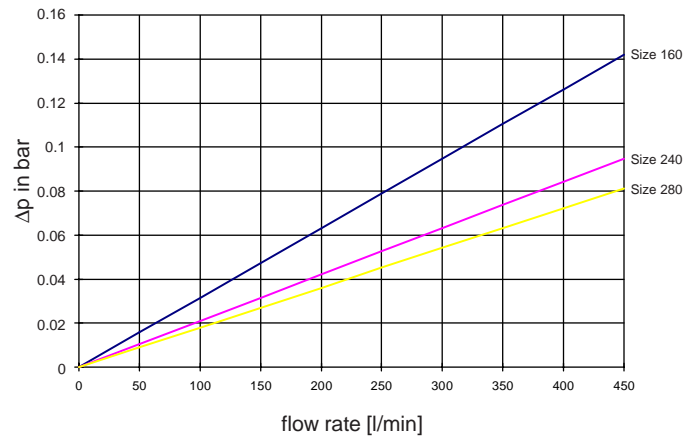

5.3. EXAMPLE

General

$$\Delta p_{\text{total}} = \Delta p_{\text{housing}} + \Delta p_{\text{element}} \cdot \frac{\text{viscosity}(\text{mm}^2/\text{s})}{30 \text{ mm}^2/\text{s}}$$

$\Delta p_{\text{housing}}$ = to be determined in accordance with Point 5.1.

$\Delta p_{\text{element}}$ = element pressure drop at flow rate Q and viscosity $v = 30 \text{ mm}^2/\text{s}$ from graphs in Point 5.2.

Example

System parameters: Q = 100 l/min;
LPF 280 with BN3HC element 10 μm;
Viscosity = 100 mm²/s
(ISO VG 100 at 40 °C);

$$\Rightarrow \Delta p_{\text{housing}} = 0.15 \text{ bar (LPF 280)}$$

$$\Delta p_{\text{element}} = 0.2 \cdot \frac{100 \text{ mm}^2/\text{s}}{30 \text{ mm}^2/\text{s}} = 0.66 \text{ bar}$$

$$\Delta p_{\text{total}} = \Delta p_{\text{housing}} + \Delta p_{\text{element}} = \underline{\underline{0.82 \text{ bar}}}$$

6. DIMENSIONS

6.1. LPF 160 - 280

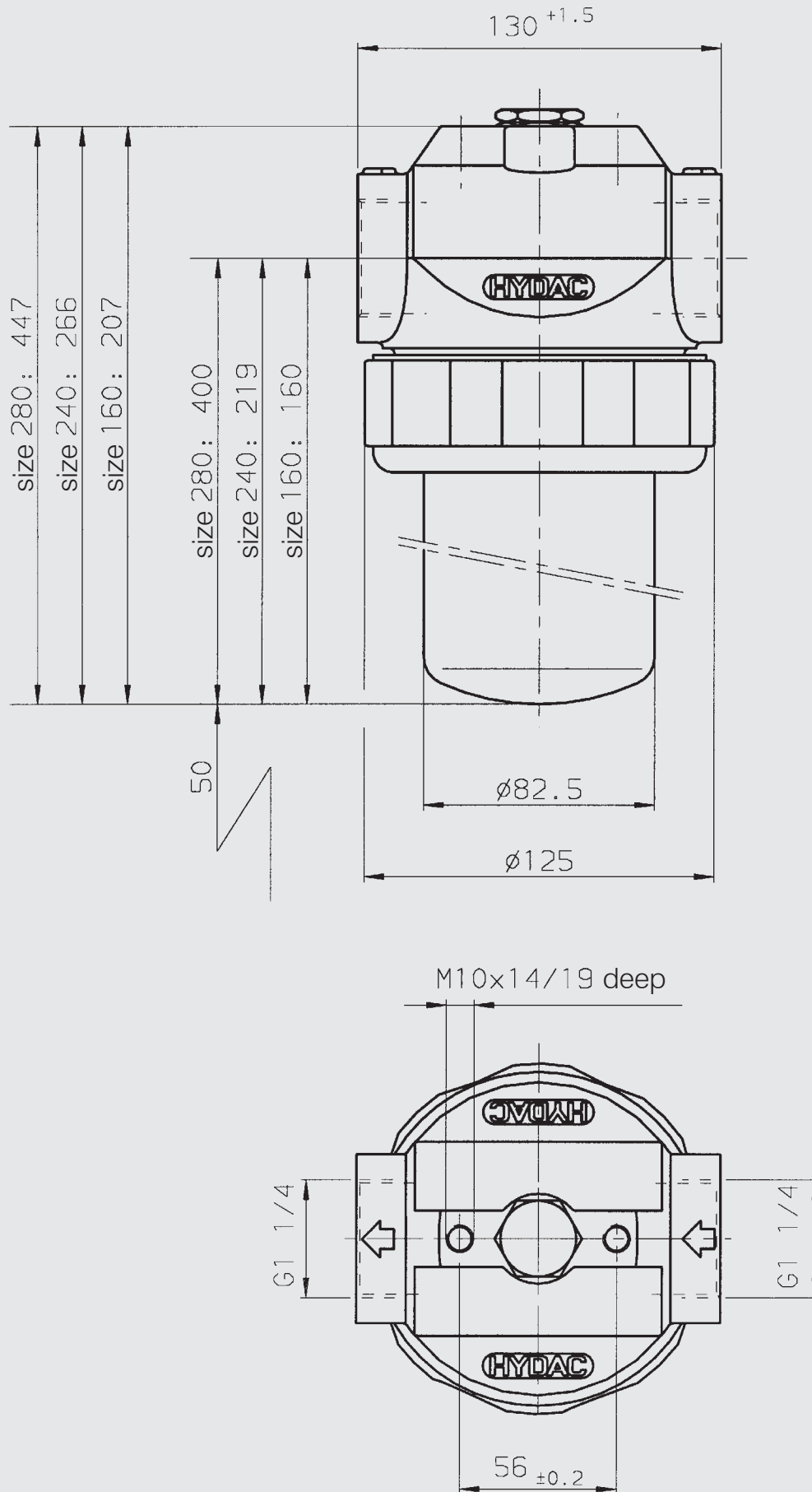

7. NOTE

The information in this brochure relates to the operating conditions and applications described.
For applications or operating conditions not described, please contact the relevant technical department.
Subject to technical modifications.

