

Electronic Pressure Transmitter

For shipbuilding and offshore HDA 4000

Description:

This pressure transmitter has been specially developed for shipbuilding and offshore applications and is based on the HDA 4000 series. By using ceramic measurement cells, absolute and relative pressure measurements can be made in the low pressure range. Stainless steel measurement cells are used for measuring in the high pressure range.

The evaluation electronics using HYDAC-ASIC converts a measured pressure into a proportional analogue signal of 4 .. 20 mA.

The electronic module is completely sealed to protect it against humidity, vibrations and shock, and is enclosed in a solid stainless steel housing.

For use in the shipbuilding industry, these pressure transmitters have the following approvals:

Approvals:

- American Bureau of Shipping



- Lloyds Register of Shipping



- Det Norske Veritas



- Germanischer Lloyd



- Bureau Veritas



Other approvals on request



Electrical connection:

Binder connection, Series 714

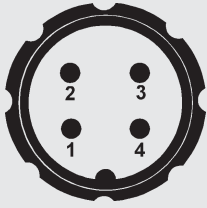

Pin 1 free
Pin 2 signal +
Pin 3 signal -
Pin 4 free

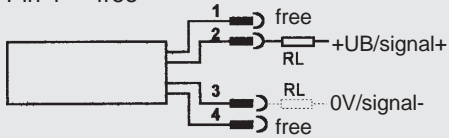

$$RL_{max.} = (UB - 10V) / 20 \text{ mA} \text{ [k}\Omega\text{]}$$

DIN 43650 connection, 3 pole + earth

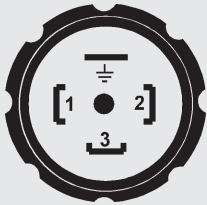

Pin 1 signal +
Pin 2 signal -
Pin 3 free
Pin 4 GND

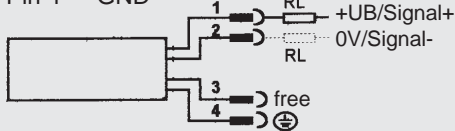

$$RL_{max.} = (UB - 10V) / 20 \text{ mA} \text{ [k}\Omega\text{]}$$

M12x1 connection, 4 pole

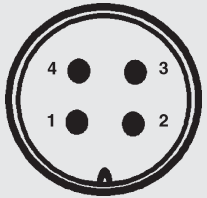

Pin 1 signal +
Pin 2 free
Pin 3 signal -
Pin 4 free

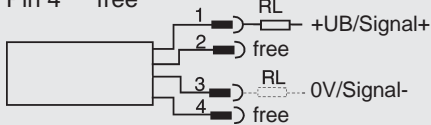

$$RL_{max.} = (UB - 10V) / 20 \text{ mA} \text{ [k}\Omega\text{]}$$

Note

The load resistance RL is produced by the measuring resistance inside the evaluation unit and the line resistance of the connection line.

Electrical accessories

For models HDA 4XX4:

ZBE 02 Binder connector
4 pole, series 714M18, straight
(must be ordered separately)

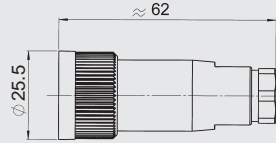

ZBE 03 Binder connector
4 pole, series 714M18, right-angled
(must be ordered separately)

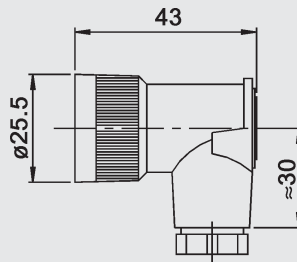

For models HDA 4XX5:

ZBE 01 3 pole + earth connector,
DIN 43650 (must be ordered separately)

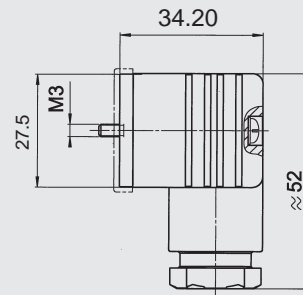

ZBE 09 3-pole connector, DIN 43650, large
(must be ordered separately)

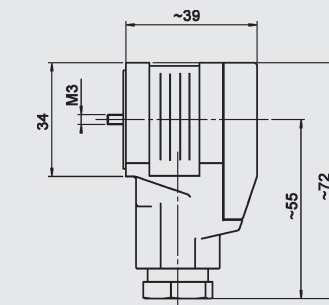

For models HDA 4XX6:

ZBE 06 4 pole, M12x1 connector,
right-angled
(must be ordered separately)

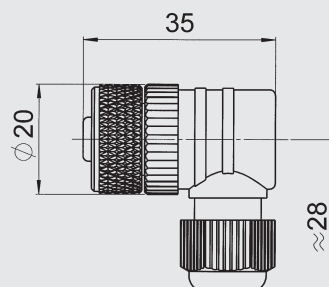

ZBE 06-02 4-pole connector with 2 m
cable, right-angled
(must be ordered separately)

ZBE 06-05 4-pole connector with 5 m
cable, right-angled
(must be ordered separately)

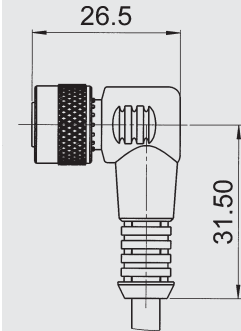

Colour code
Pin 1 brown
Pin 2 white
Pin 3 blue
Pin 4 black

ZBE 06S-05 4-pole connector with 5 m
screened cable, right-angled
(must be ordered separately)

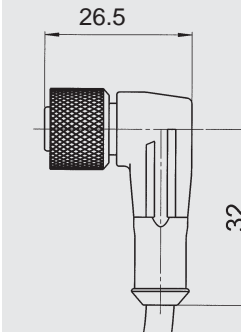

Colour code
Pin 1 brown
Pin 2 white
Pin 3 blue
Pin 4 black

Mechanical accessories:

ZBM 02 Adaptor G 1/4 I - G1/2A
DIN 3852

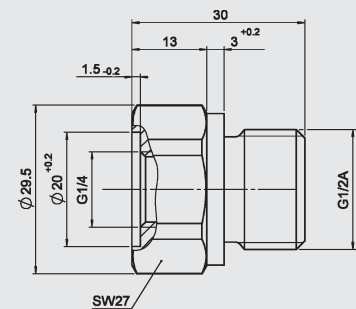

ZBM 13 Adaptor G 1/4 I - G1/4A
with orifice 0.5 mm

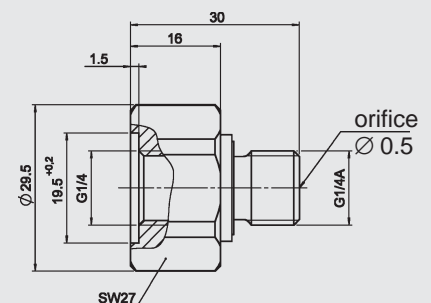

Technical specifications:

Input data	HDA 4100	HDA 4300	HDA 4400	HDA 4700
Measuring ranges / [bar]	1; 2.5 (absolute)	1; 2.5; 4; 6; 10; 16; 25; 40 -1..1; -1..5; -1..9 (relative)	6; 16; 40; 60; 100; 250; 400; 600	6; 16; 40; 60; 100; 250; 400; 600
Measuring ranges / [psi]	15; 50	15; 30; 50; 100; 150; 250; 500	150; 750; 1000; 1500; 3000; 5000; 6000; 9000	150; 750; 1000; 1500; 3000; 5000; 6000; 9000
Overload pressures	200 % FS	200 % FS	200 % FS, max. 900 bar (13050 psi)	200 % FS, max. 900 bar (13050 psi)
Burst pressures	400 % FS, max. 12 bar (170 psi)	400 % FS, max. 300 bar (4350 psi)	400 % FS, max. 2000 bar (29000 psi)	400 % FS, max. 2000 bar (29000 psi)
Parts in contact with media	Ceramic, stainless steel Seals: FPM, EPDM	Ceramic, stainless steel Seals: FPM, EPDM	Stainless steel; Seal: FPM,	Stainless steel, Seal: FPM,
Output data				
Curve deviation at max. setting to DIN 16086 (accuracy class)	≤ ± 1 % FS max. ≤ ± 0.5 % FS typ.	≤ ± 1 % FS max. ≤ ± 0.5 % FS typ.	≤ ± 1 % FS max. ≤ ± 0.5 % FS typ.	≤ ± 0.5 % FS max. ≤ ± 0.25 % FS typ.
Curve deviation at min. setting to (B.F.S.L)	≤ ± 0.5 % FS max. ≤ ± 0.25 % FS typ.	≤ ± 0.5 % FS max. ≤ ± 0.25 % FS typ.	≤ ± 0.5 % FS max. ≤ ± 0.25 % FS typ.	≤ ± 0.25 % FS max. ≤ ± 0.15 % FS typ.
Temperature compensation zero point	≤ ± 0.3 % / 10 K max ≤ ± 0.2 % / 10 K typ.	≤ ± 0.3 % / 10 K max ≤ ± 0.2 % / 10 K typ.	≤ ± 0.25 % / 10 K max ≤ ± 0.15 % / 10 K typ.	≤ ± 0.15 % / 10 K max. ≤ ± 0.08 % / 10 K typ.
Temperature compensation over range	≤ ± 0.3 % / 10 K max. ≤ ± 0.2 % / 10 K typ.	≤ ± 0.3 % / 10 K max ≤ ± 0.2 % / 10 K typ.	≤ ± 0.25 % / 10 K max. ≤ ± 0.15 % / 10 K typ.	≤ ± 0.15 % / 10 K max. ≤ ± 0.08 % / 10 K typ.
Linearity at max. setting to DIN 16086	≤ ± 0.5 % FS max. ≤ ± 0.25 % FS typ.	≤ ± 0.5 % FS max. ≤ ± 0.25 % FS typ.	≤ ± 0.3 % FS max. ≤ ± 0.15 % FS typ.	≤ ± 0.3 % FS max. ≤ ± 0.15 % FS typ.
Hysteresis	≤ ± 0.25 % FS max. ≤ ± 0.125 % FS typ.	≤ ± 0.25 % FS max. ≤ ± 0.125 % FS typ.	≤ ± 0.4 % FS max. ≤ ± 0.2 % FS typ.	≤ ± 0.1 % FS max. ≤ ± 0.05 % FS typ.
Repeatability	≤ ± 0.1 % FS	≤ ± 0.1 % FS	≤ ± 0.1 % FS	≤ ± 0.05 % FS
Rise time	approx. 2 ms	approx. 2 ms	approx. 2 ms	approx. 2 ms
Long-term drift	≤ ± 0.3 % FS typ. / year	≤ ± 0.3 % FS typ. / year	≤ ± 0.3 % FS typ. / year	≤ ± 0.1 % FS typ. / year
Ambient conditions				
Nominal temperature range	0 .. +80 °C	0 .. +80 °C	-25 .. +85 °C	-25 .. +85 °C
Operating temperature range	-25 .. +85 °C *	-25 .. +85 °C *	-25 .. +85 °C **	-25 .. +85 °C **
Storage temperature range	-30 .. +100 °C	-30 .. +100 °C	-40 .. +100 °C	-40 .. +100 °C
Fluid temperature range	-25 .. +100 °C *	-25 .. +100 °C *	-25 .. +100 °C **	-25 .. +100 °C **
CE - mark	EN 61000-6-1/2/3/4	EN 61000-6-1/2/3/4	EN 61000-6-1/2/3/4	EN 61000-6-1/2/3/4
Vibration resistance to IEC 68-2-6 at 10 .. 500 Hz	≤ 20 g (196.2 m/s ²)	≤ 20 g (196.2 m/s ²)	≤ 20 g (196.2 m/s ²)	≤ 20 g (196.2 m/s ²)
Protection class to DIN 40050	Models with connectors: IP 65	Models with connectors: IP 65	Models with connectors: IP 65	Models with connectors: IP 65
Other data				
Supply voltage 2-conductor	10 .. 32 V	10 .. 32 V	10 .. 32 V	10 .. 32 V
Residual ripple of supply voltage	≤ 5 %	≤ 5 %	≤ 5 %	≤ 5 %
Reverse polarity protection of the supply voltage, excess voltage, override and short circuit protection	provided	provided	provided	provided
Life expectancy	10 million load cycles 0 .. 100 % FS	10 million load cycles 0 .. 100 % FS	10 million load cycles 0 .. 100 % FS	10 million load cycles 0 .. 100 % FS
Weight	approx. 150 g	approx. 150 g	approx. 150 g	approx. 150 g

Note:

FS (Full Scale) = relative to the full measuring range

B.F.S.L. = Best Fit Straight Line

* optional up to -30°C (depending on the seal material)

** optional up to -40°C (depending on the seal material)

Order code

Pressure transmitter with ceramic measurement cell

HDA 4 X X X - A - XXXX - S00 - X1 (PSI) XX inch

Accuracy class

- 1 = 1 % FS max., absolute
- 3 = 1 % FS max., relative

Mechanical connection

- 2 = G 1/2 A DIN 3852, male
- 4 = G 1/4 A DIN 3852, male
- 8 = 1/4-18 NPT, male

Electrical connection

- 4 = series 714 M18, 4 pole, IP 65
- 5 = DIN 43650, 3 pole + earth, IP 65
- 6 = M12x1, 4 pole, IP 65

Signal

- A = 4 .. 20 mA

Measuring ranges

For accuracy class "1" (absolute measurements)

01.0; 02.5 bar
0015; 0050 psi

for accuracy class "3" (relative measurements)

01.0; 02.5; 04.0; 06.0; 0010; 0016; 0025; 0040 bar
0001 (-1 .. +1 bar); 0005 (-1 .. +5 bar); 0009 (-1 .. +9 bar)
0015; 0030; 0050; 0100; 0150; 0250; 0500 psi

Modification number

- S00 = with shipbuilding approvals

Seal material (in contact with fluid)

- F = FPM seal (e.g.: for hydraulic oils)
- E = EPDM seal (e.g.: for refrigerants)

Connector material (in contact with fluid)

- 1 = stainless steel

psi

Additional code for psi measuring ranges (not applicable for bar measuring ranges)

Cable length (e.g. for conduit pipe connection or flying lead)

Please give details in cm or inch (not applicable for connectors)

Pressure transmitter with stainless steel measurement cell

HDA 4 X X X - A - XXXX - S00 - (PSI) XX inch

Accuracy class

- 4 = 1 % FS max.
- 7 = 0.5 % FS max.

Mechanical connection

- 2 = G 1/2 A DIN 3852, male
- 4 = G 1/4 A DIN 3852, male
- 7 = 9/16-18 UNF 2A (SAE 6), male

Electrical connection

- 4 = series 714 M18, 4 pole, IP 65
- 5 = DIN 43650, 3 pole + earth, IP 65
- 6 = M12x1, 4 pole, IP 65

Signal

- A = 4 .. 20 mA

Measuring ranges

06.0; 0016; 0040; 0060; 0100; 0250; 0400; 0600 bar
0150; 0750; 1000; 1500; 3000; 5000; 6000; 9000 psi

Modification number

- S00 = with shipbuilding approvals

psi

Additional code for psi measuring ranges (not applicable for bar measuring ranges)

Cable length (e.g. for conduit pipe connection or flying lead)

Please give details in cm or inch (not applicable for connectors)

Dimensions HDA 4X45 with ZBE 01

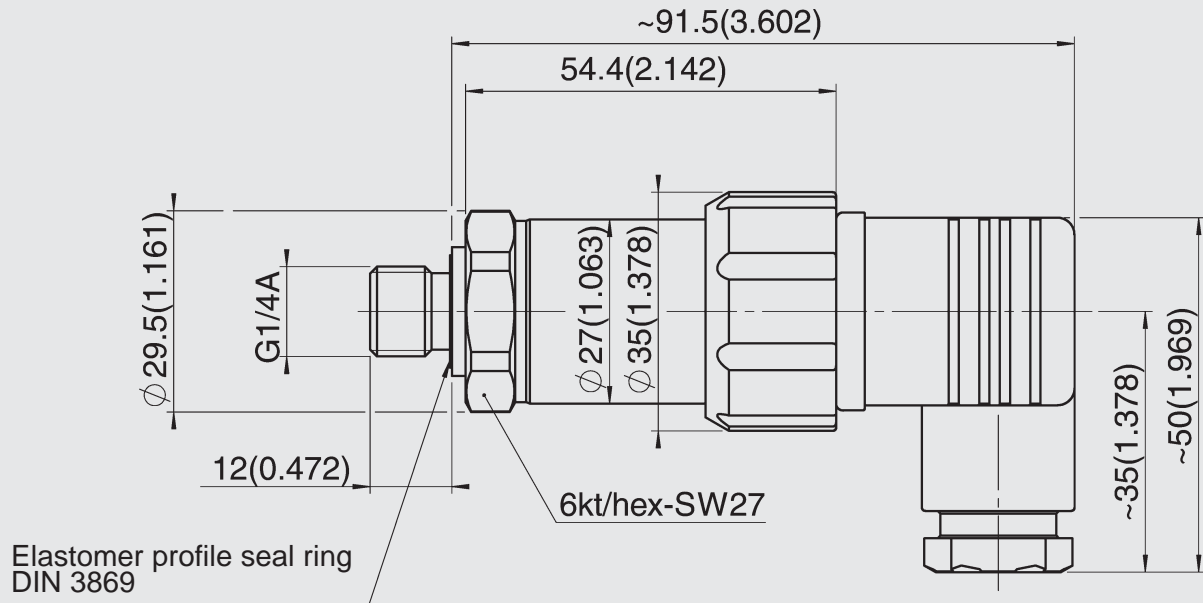

Additional types of mechanical connection

HDA 4X2X

Threaded end to DIN 3852-E-G1/2A

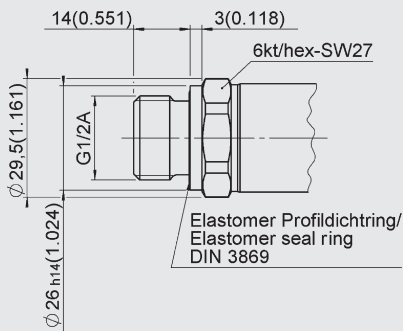

HDA 4X8X

Threaded end 1/4 - 18NPT

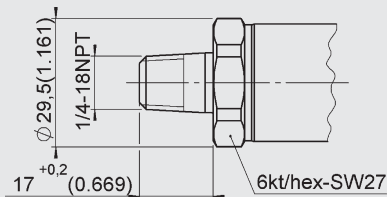

Note:

The information in this brochure relates to the operating conditions and applications described.

For applications or operating conditions not described, please contact the relevant technical department.

Subject to technical modifications.

HDA 4X7X

Threaded end to SAE6

