

# Electronic Temperature Sensor ETS 300

## Description:

The ETS 300 is a compact electronic temperature sensor with digital display. Two different models are available for optimum adaptation to particular applications.

The ETS 300 with built-in temperature sensor has a measuring range from  $-25\text{ }^{\circ}\text{C}$  to  $+100\text{ }^{\circ}\text{C}$ . It is pressure-resistant to 600 bar and can therefore be mounted directly on the hydraulic block, if required.

The model with a separate sensor input has a display range of  $-30\text{ }^{\circ}\text{C}$  to  $+150\text{ }^{\circ}\text{C}$ . The unit is mainly used together with the temperature sensor TFP 100 which was specially developed for tank mounting. However, commercially available PT 100 temperature sensors can also be used.

Different output models with one or two switching outputs, optionally with an additional analogue output signal 4 .. 20 mA, offer a variety of application possibilities.

The switching points and the associated hystereses can be adjusted very quickly and easily via the membrane keypad.

For optimum adaptation to the particular application, the unit has many additional adjustment parameters (e.g. switching delay times, N/O / N/C function of the outputs).

## Special features:

- Compact temperature sensor with integral or separate temperature sensor
- 2 transistor switching outputs, output capacity 1.2 A each
- Option: analogue output 4 .. 20 mA
- Switching point function or window function
- Many useful additional functions.

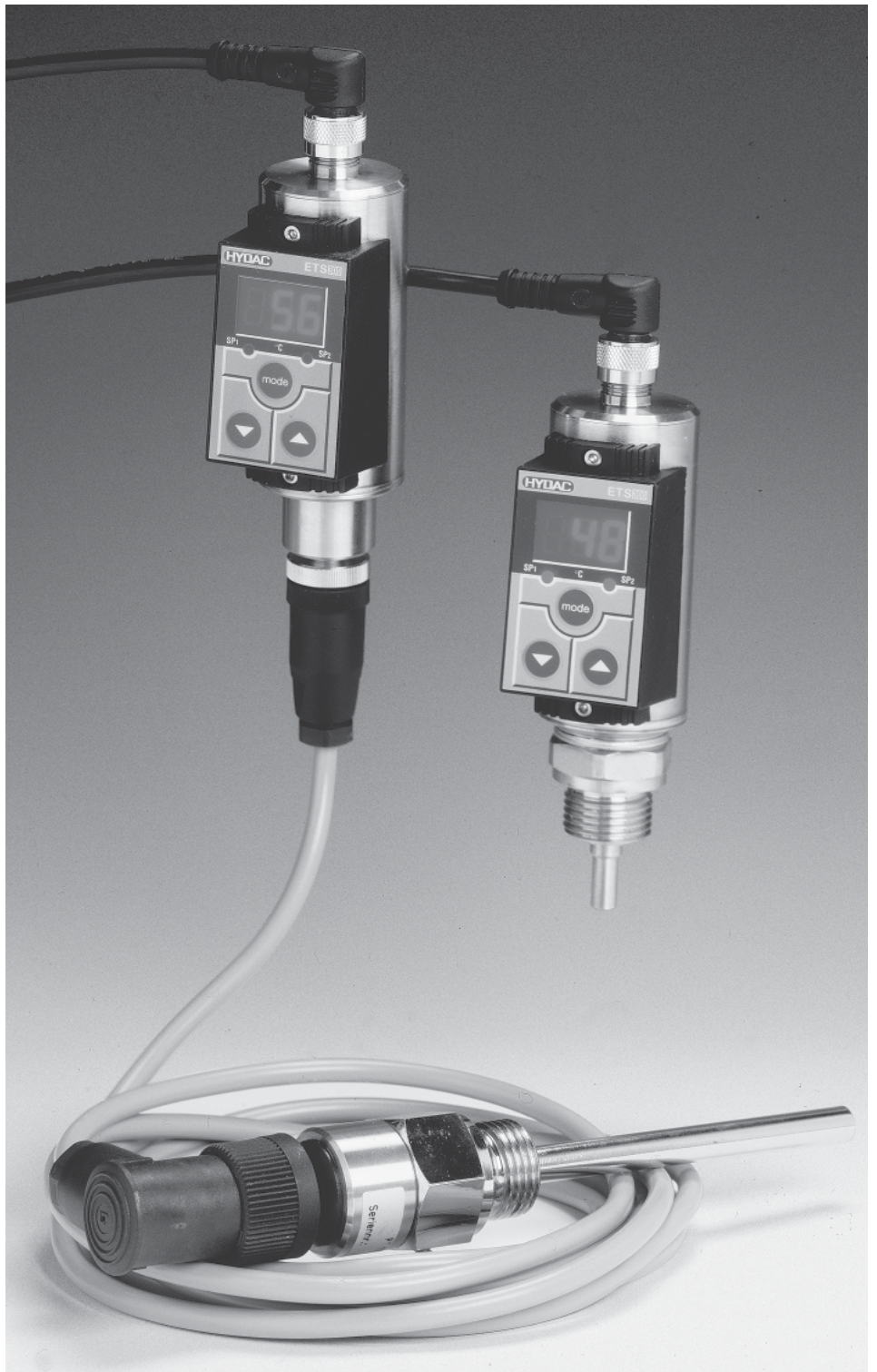

## Setting options:

All the settings available on the ETS 300 are combined in two easy-to-follow menus. To prevent unauthorised adjustment of the unit, a program disable can be activated.

## Setting ranges of the switching points and hystereses and/or switching values for the window function:

### Version with integral sensor

Measuring range	Switching point or upper switching value	Hysteresis or lower switching value	Increment*
in °C (°F)	in °C (°F)	in °C (°F)	in °C (°F)
-25 .. 100 (-13 .. 212)	-22 .. 100 (-10 .. 212)	1 .. 123 (1 .. 223)	1 (1)

### Version with separate sensor

Measuring range	Switching point or upper switching value	Hysteresis or lower switching value	Increment*
in °C (°F)	in °C (°F)	in °C (°F)	in °C (°F)
-30 .. 150 (-22 .. 302)	-27 .. 150 (-16 .. 302)	1 .. 178 (2 .. 320)	1 (2)

\*All ranges given in the table are adjustable by the increments shown.

## Additional functions:

- Switching mode of the switching outputs adjustable (switching point function or window function)
- Switching direction of the switching outputs adjustable (N/O or N/C function)
- Switch-on delay adjustable between 0.00 .. 750 seconds
- Switch-back delay adjustable between 0.00 .. 750 seconds
- Choice of display (current temperature, switching point 1, switching point 2, peak value, display off)

## Switching point / switch-back point:

The switching point is defined as being the temperature value, which when reached (whilst temperature is increasing), causes a change in the switching output. This output state is maintained until the temperature falls below the switch-back hysteresis allocated to the switching point. The switch-back point is determined by the pre-set switch-back hysteresis (switching point minus switch-back hysteresis = switch-back point).

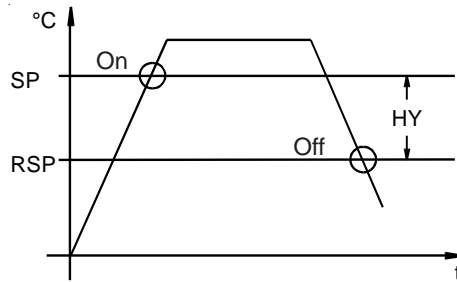

SP = switching point  
 HY = switch-back hysteresis  
 RSP = switch-back point (switching point minus switch-back hysteresis)

## Window function:

The window function enables the set points to be operated within a band limit.

For each switching output, an upper and a lower switching value can be input which determine the range. The respective output switches when the temperature enters this range. Upon leaving the range, the output switches back.

## Circuit diagram:

### Supply voltage, switching outputs, analogue output

#### Model with 2 switching outputs:

4 pole connector, M12x1

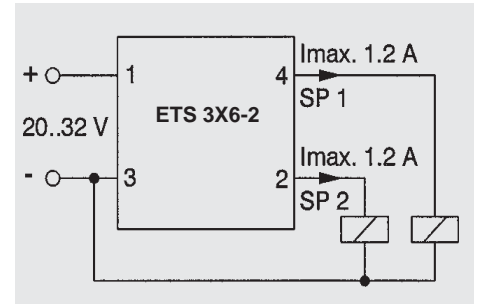

#### Model with 1 switching output and 1 analogue output:

4 pole connector, M12x1

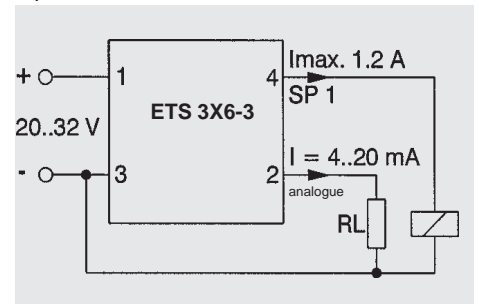

#### Model with 2 switching outputs and 1 analogue output:

5 pole connector, M12x1

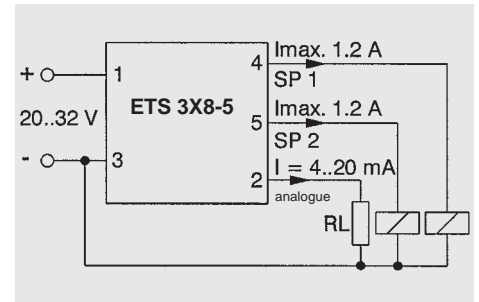

## Sensor connection

### (Version with separate sensor)

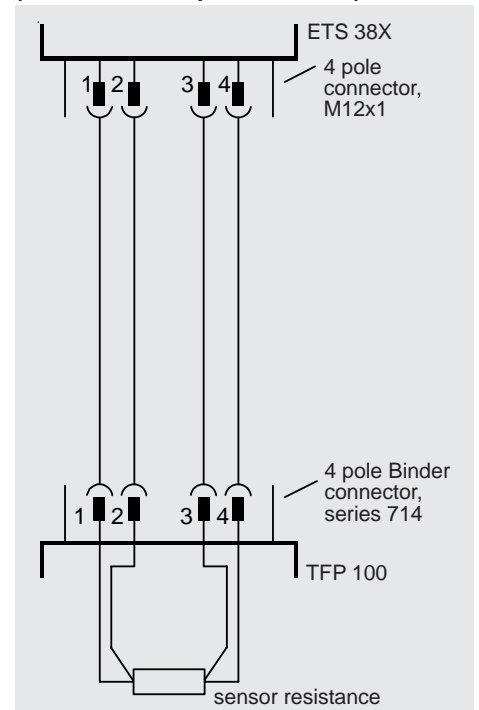

## Electrical accessories:

### ZBE 03

(supplied with the temperature sensor TFP 100)

Right-angled, 4 pole Binder connector, series 714 M18

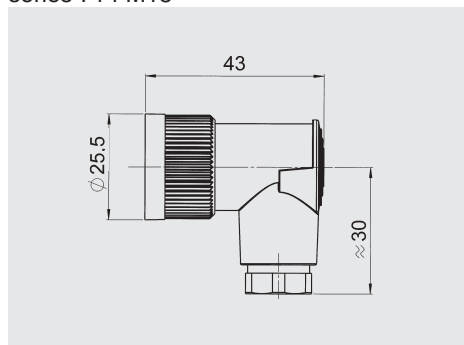

### ZBE 06 (for ETS 3X6)

Right-angled, 4 pole Binder connector, M12x1

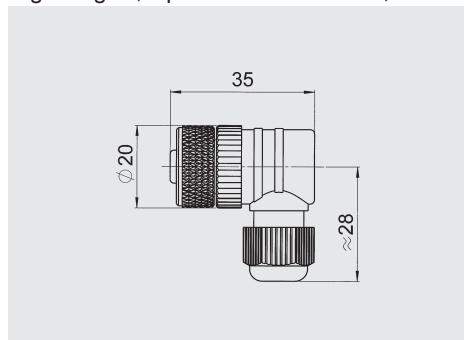

### ZBE 06-02 (for ETS 3X6)

Right-angled, 4 pole connector, M12x1, with 2 m cable

### ZBE 06-05 (for ETS 3X6)

Right-angled, 4 pole connector, M12x1, with 5 m cable

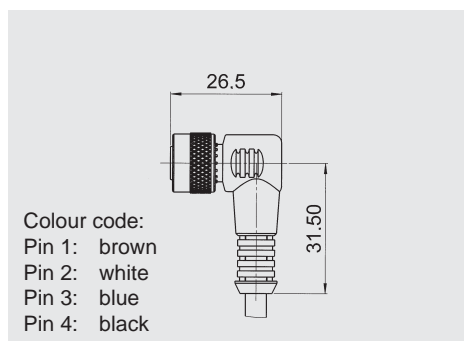

Colour code:  
Pin 1: brown  
Pin 2: white  
Pin 3: blue  
Pin 4: black

### ZBE 08 (for ETS 3X8)

Right-angled, 5 pole connector, M12x1

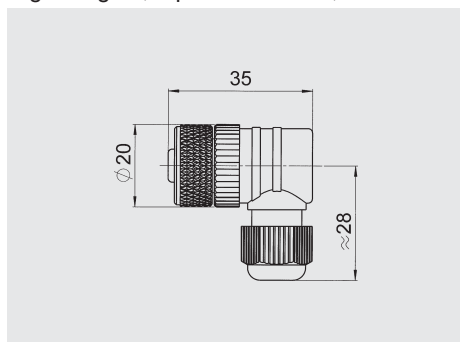

### ZBE 08-02 (for ETS 3X8)

Right-angled, 5 pole connector, M12x1, with 2 m cable

### ZBE 08-05 (for ETS 3X8)

Right-angled, 5 pole connector, M12x1, with 5 m cable

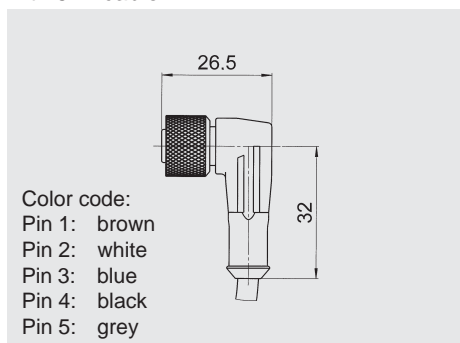

Color code:  
Pin 1: brown  
Pin 2: white  
Pin 3: blue  
Pin 4: black  
Pin 5: grey

## Mechanical accessories:

### ZBM 300

Clamp for wall-mounting the ETS 38X (material: polypropylene)

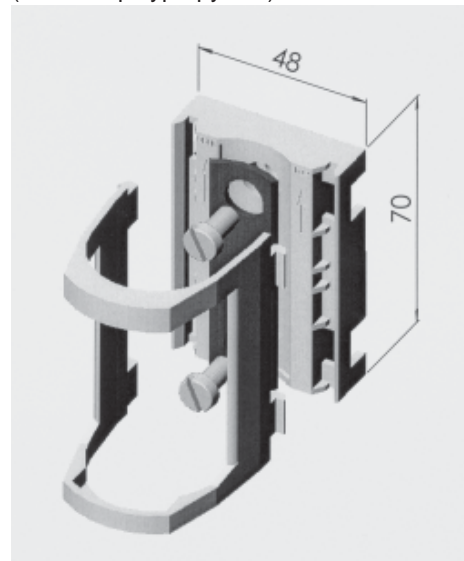

### ZBM 310

Clamp for wall-mounting the ETS 38X (materials: polypropylene, aluminium AISi12, steel)

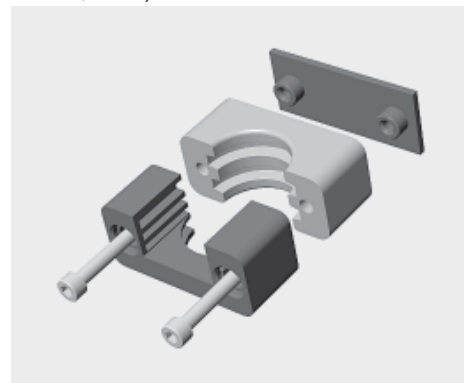

## Technical specifications:

### Input data for integral sensor:

Measuring range:	-25 .. 100 °C (-13 .. 212 °F)
Pressure resistance:	600 bar
Hydraulic connection:	G1/2 A DIN 3852
Torque rating:	approx. 45 Nm
Parts in contact with medium:	stainless steel, seal: FPM

### Input data for separate sensor:

Display range: *)	-30 .. 150 °C (-22 .. 302 °F)
Sensor connection:	connector M 12x1, 4 pole

### Output data:

Accuracy (display, analogue output)	$\leq \pm 1.0$ °C ( $\leq \pm 2.0$ °F)
Temperature drift (zero point and range):	$\leq \pm 0.15$ % /10 K
Reaction time ( $T_{90}$ ):	approx. 20 s
Analogue output:	4 .. 20 mA, ohmic resistance $\leq 400$ $\Omega$

### Switching outputs:

Type:	PNP transistor output
Switching current:	max. 1.2 A

### Ambient conditions:

Temperature range of medium:	-25 .. + 100 °C (integral sensor)
Ambient temperature range:	-25 .. + 80 °C
Storage temperature range:	-40 .. + 80 °C
Nominal temperature range:	-10 .. + 70 °C
CE - mark:	EN 61000-6-1/2/3/4
Vibration resistance:	approx. 10 g / 0 .. 500 Hz
Shock resistance:	approx. 50 g / 1ms

### Other data:

Supply voltage:	20 .. 32 VDC
Current consumption:	approx. 100 mA (no switching output)
Safety type:	IP 65
Material of housing:	tube: stainless steel keypad housing: PA6.6 Gf30
Display:	3-digit, 7-segment LED, red, height of digits 9.2 mm
Weight:	approx. 300 g

## Technical specifications - Accessories:

### Temperature sensor TFP 100:

Temperature range of medium (for TFP 100):	-40 .. +125 °C / -40 .. +257 °F
Electrical connection:	4-pole Binder connector, series 714 M18

### Safety sleeve for tank-mounting the TFP 100

Parts in contact with medium:	All materials compatible with nickel
-------------------------------	--------------------------------------

**Note:\*)** Depending on the temperature range of the temperature sensor fitted, this can reduce the display range of the ETS 300 with separate sensor input.

## Model code:

ETS 3 X X - X - XXX - 000

### Series no.

(determined by manufacturer)

### Type of connection, mechanical

2 = G 1/2 A male thread with integral sensor

8 = electrical connection for separate sensor (TFP 100)

### Type of connection, electrical

6 = 4 pole plug, M 12x1

only available for output models "2" and "3"

(connector not included)

8 = 5 pole plug M12x1

only available for output model "5"

(connector not included)

### Output

2 = 2 switching outputs

(only in conjunction with electrical connection type "6")

3 = 1 switching output and 1 analogue output

(only in conjunction with electrical connection type "6")

5 = 2 switching outputs and 1 analogue output

(only in conjunction with electrical connection type "8")

### Measuring ranges

100 = -25 .. 100 °C (-13 .. 212 °F) only for version with integral sensor

150 = -30 .. 150 °C (-22 .. 302 °F) only for version with separate sensor<sup>1)</sup>

### Modification number

000 = display in °C (determined by manufacturer)

400 = display in °F (determined by manufacturer)

<sup>1)</sup> depending on the sensor fitted (see page 4)

## Accessories supplied:

- 4 pole connector, M12x1
- 3 m cable for TFP 100 (LIYY 4 x 0.5 mm<sup>2</sup>)

## Other accessories:

(must be ordered separately)

- Temperature sensor TFP 100 (connector ZBE 03 included)
- Safety sleeve for tank mounting
- Connectors ZBE06/ZBE08 (for model, see page 3)
- Clamps for wall-mounting ZBM300/ZBM310

## Note:

The information in this brochure relates to the operating conditions and applications described.

For applications or operating conditions not described, please contact the relevant technical department.

Subject to technical modifications.

## Dimensions:

