

## Cooling systems

FWKS-2/1.0/W...

### 1. DESCRIPTION

#### 1.1. APPLICATIONS

- Closed-loop cooling circuits
- Cooling of AC main drives
- Cooling of motor spindles on machining centres
- Cooling of transmission and braking systems
- Cooling of servomotors

#### 1.2. CONSTRUCCION

The FWKS fluid cooling system consists of a tank, a submersible pump and a plate heat exchanger.

The submersible pump built into the plastic tank pumps coolant through the plate heat exchanger.

A secondary cooling water circuit, which also flows through the heat exchanger, provides the necessary cooling.



## 2. TECHNICAL SPECIFICATIONS

2.1. COOLING CAPACITY AND FLOW RATE OF PUMP  
see graphs 2.12 & 2.13)

2.2. PERMISSIBLE FLUID

2.2.1 **Preferred fluid:**

Mains water with 30-40%  
GLYSANTIN G48 PROTECT  
PLUS (BASF)

2.2.2 **Other permissible fluids:**

Mains water with 30-40%  
-PARAFLU 11

Mains water with 5-10%  
-MOTOREX COOLANT-F

Other coolants on request

2.3. PERMISSIBLE TEMPERATURES

2.3.1 **Fluid temperature**

max. 60 °C

2.3.2 **Ambient temperature**

0 °C to +40 °C

2.4. MOUNTING POSITION

Vertical (pump motor at the top)

2.5. NOISE LEVEL MEASURED TO  
DIN45635 PT1

FWKS-2: 61 dB(A)

2.6. DIRECTION OF ROTATION

Pump: when looking at motor fan,  
clockwise

2.7. TANK SIZE:

Max. 9,5 l, Min. 7 l

2.8. WEIGHT

42 kg (Standard)

2.9. ELECTRICAL CONNECTION

Provided by customer: 10 pole  
plug connector e.g. HARTING  
housing 09300101541 and female  
insert 09330102716 (see 5.0)

2.10. HYDRAULIC CONNECTION

Operating fluid

feed flow connection: P= 3/4"

Operating fluid

return flow connection K=3/4"

Water circuit:

inlet: W1=3/4" (Standard)

outlet: W2= 3/4"

Option flow controller

W1= 1/2"

Do not reduce pipe cross-section  
pre-determined by the threaded  
connections.

(see 2.12 )

2.11. ELECTRICAL SPECIFICATIONS

380-420V 50HZ

440-480V 60HZ

Voltage tolerances to

EN 60034-1 ±5%

Motor rated current:

See type code label on electric  
motor

Motor output:

at 50HZ: 2 pol. 0,5 KW

at 60HZ: 2 pol. 0,7 KW

## 2.12. PUMP FLOW RATE GRAPH

The operating point of the pump (flow rate) is dependent on the system characteristics (pipe cross-sections, pipe lengths, threaded connections). The following generally applies: The smaller the pressure losses in the system, the greater the flow rate and therefore the cooling performance is greater.

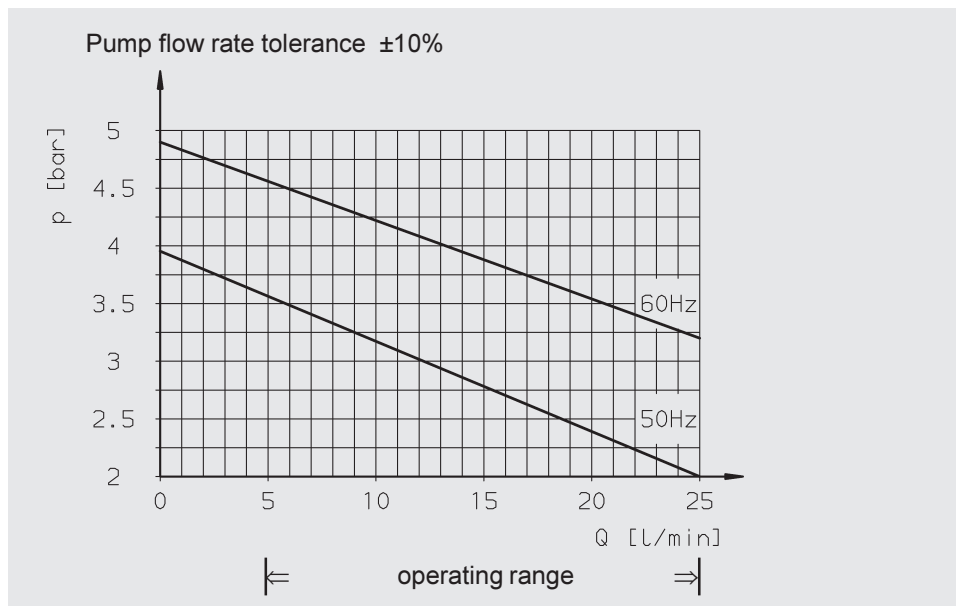

## 2.13. COOLING CAPACITY DIAGRAM

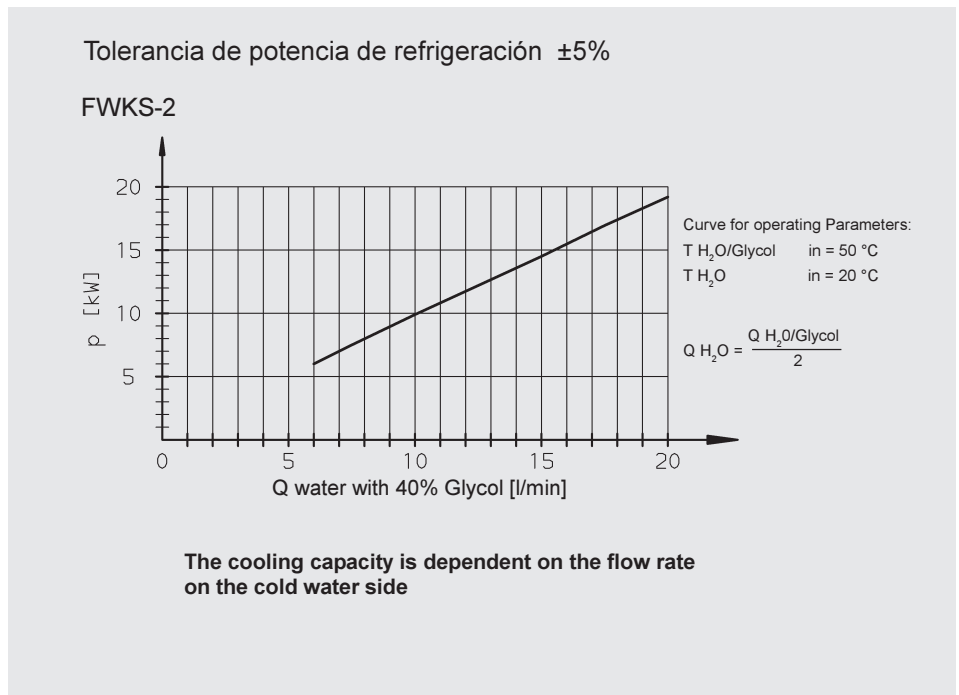

### 3. MODEL CODE

(also order example)

FWKS- 2 / 1. 0 / W / TP / 400-50 / WP24-20 1 / 0

**Fluid Water Cooling System** \_\_\_\_\_

FWKS

**TNominal size** \_\_\_\_\_

2

**Type code** \_\_\_\_\_

**Modification no.** \_\_\_\_\_

**Fluid** \_\_\_\_\_

W (see 2.2.)

**Submersible pump** \_\_\_\_\_

**Motor voltage** (standard) \_\_\_\_\_

380-420V (Y) 50HZ

440-480V (Y) 60HZ

**Plate heat exchanger** \_\_\_\_\_

WP 24 - 20

**Paint** \_\_\_\_\_

1=RAL 7043 (standard)

**Accessories (see Point 6.)** \_\_\_\_\_

0 = Standard (without accessories)

1 = Electrical fluid level and temperature monitoring

2 = Pressure gauge

3 = Fluid level and temperature monitoring & pressure gauge

9 = Proportional control valve for temperature-dependent control of the water volume

11 = Flow indicator

## 4. DIMENSIONS

FWKS-2

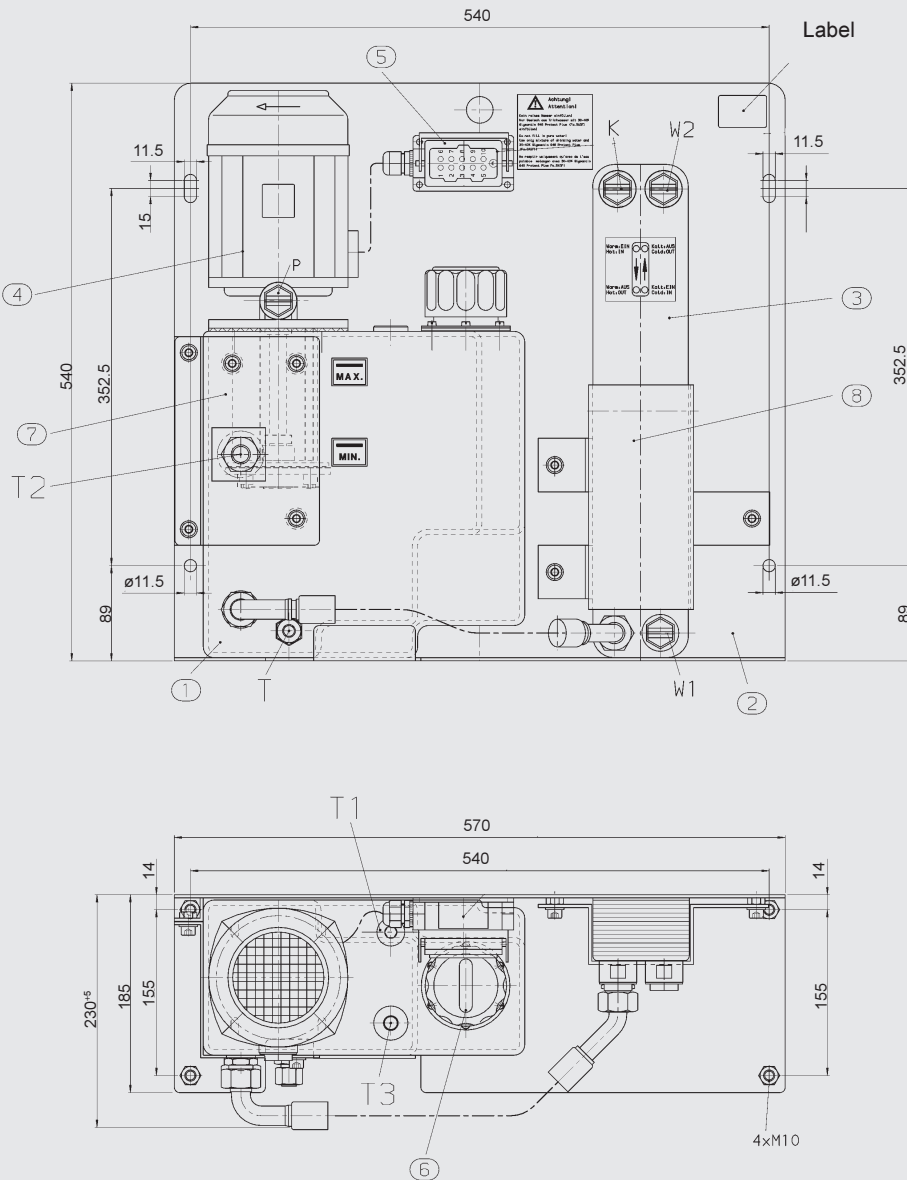

- ① Expansion tank
- ② Mounting plate
- ③ Heat exchanger
- ④ Pump
- ⑤ Heavy duty rectangular connector with 1x locking clip and 10 pole pin insert
- ⑥ Tank breather filter ELF-3
- ⑦ Mounting for tank
- ⑧ Mounting for heat exchanger

### Hydraulic connections:

|   |                        |
|---|------------------------|
| Pump (feed flow) :  | P = 3/4"               |
| Operating fluid return flow :   | K = 3/4"               |
| <u>Secondary inlet, water :</u><br>plate heat exchanger (with accessory 9): | W1 = 3/4"<br>(W1=1/2") |
| <u>Secondary outlet, water :</u><br>plate heat exchanger                    | W2 = 3/4"              |
| Tank drain:   | T = 12L/<br>M18x1,5    |
| Tank port   | T1 = M20x1,5           |
| Tank port   | T2 = 18L/<br>M26x1,5   |
| Tank port   | T3 = 1/2"              |

## 4.1. 4.1 CIRCUIT DIAGRAM

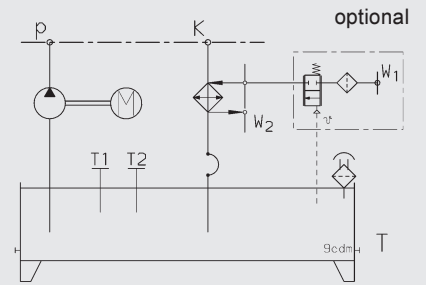

## 5. ELECTRICAL PIN CONNECTIONS

FWKS-2

Connection for female insert (to be supplied by customer)

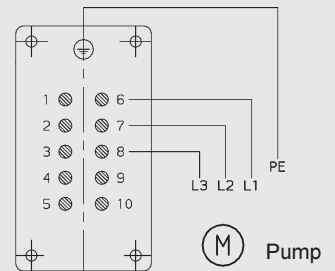

## 6. ACCESSORIES

### 1. ELECTRICAL FLUID LEVEL AND TEMPERATURE MONITORING:

Fluid level and temperature switch 63 °C (N/C);  
Monitors the level of coolant and the temperature in the tank.

### 2. PRESSURE GAUGE:

Visual pressure indication of the coolant at the pump (0-10 bar).

### 3. ELECTRICAL FLUID LEVEL AND TEMPERATURE MONITORING + PRESSURE GAUGE:

Fluid level and temperature switch 63°C (N/C);  
Monitors the level of coolant and the temperature in the tank and provides visual pressure indication of the coolant at the pump.

### 9. PROPORTIONAL CONTROL VALVE FOR TEMPERATURE-DEPENDENT CONTROL OF THE WATER VOLUME

Further accessories available on request.

### 11. FLOW INDICATOR

Flow rate monitoring of the coolant  
(switch-off point set to 5 l/min)

## 7. NOTE

The information in this brochure relates to the operating conditions and applications described.

For applications or operating conditions not described, please contact the relevant technical department.

Subject to technical modifications.