

THE LOW NOISE OIL COOLER RANGE WITH HIGH COOLING PERFORMANCE

Application

These low noise coolers with their unique vertical air flow for discharge air are suitable for all small and medium size hydraulic cooling applications with both return line and off-line versions available. Typical applications include: lifts, lubrication systems (i.e. gearboxes) and machine tools.

The SCA version with integrated oil circulation pump allows the cooler to create an off-line cooling system that can also provide high quality filtration if required with the SCAF model having the latest high performance filter also integrated.

Product features

The advantages of the off line cooling system include stable cooling (and filtration) performance irrespective of variations in flow and duty for the main hydraulic circuit. This allows the cooler to be sized to suit the heat load and not the maximum return line flow of the main circuit. A further advantage is that the off-line cooler is completely isolated from surge pressures in the return line that can potentially damage the cooler.

- Cooling range 2-20kW at ΔT 40 °C
- Noise level < 70dB(A) at 1m distance for SC - L version (low speed) at 50 Hz
- Compact, efficient and powerful
- Motor flange B5, the most commonly available type
- Simple disassembly of pump and motor

Oil/Air Cooler Units

Silent series

SC Type



Test procedure certified following EN 1048

OIL/AIR COOLER

DESCRIPTION

GENERAL

In hydraulic systems energy is transformed and transmitted. During this transformation and transmission losses occur, i.e. mechanical and hydraulic energy is converted into heat. It is the function of the cooler to dissipate this heat.

ADVANTAGES OF THE OIL/AIR COOLERS:

- Environmentally friendly. No exchange between water and oil possible
- For commissioning only electrical energy is required
- Low operating costs, no additional cooling circuit necessary for the cooling medium, i.e. air

CONSTRUCTION

Oil/air cooler units consists of the (1) metal housing, (2) motor, (3) radial fan, (4) heat exchanger, (depending on the type of unit) a (5) low noise feed pump with excellent suction performance and/ or (6) filter. The oil connections are external together with access to the filter element for cleaning and changing. The filters are fitted with visual clogging indicators as standard.

SC 1-4L,S*

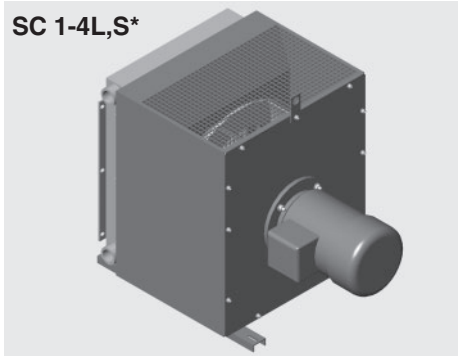

SC 0-4

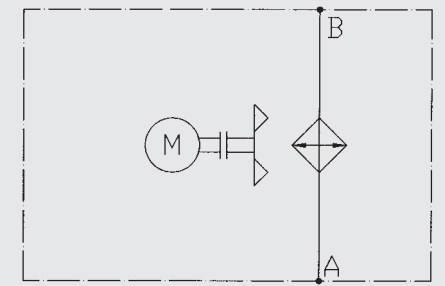

SCA 1-4L,S*

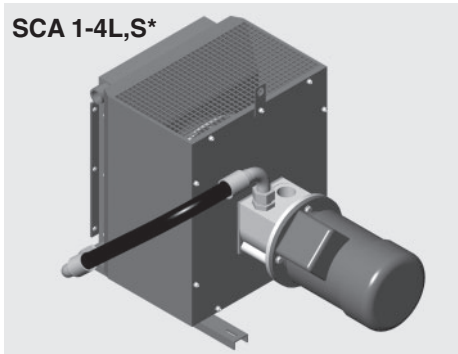

SCA 0-4

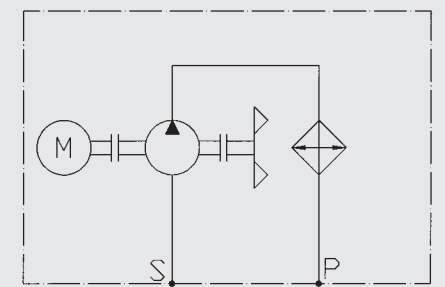

SCAF 1-4L,S*

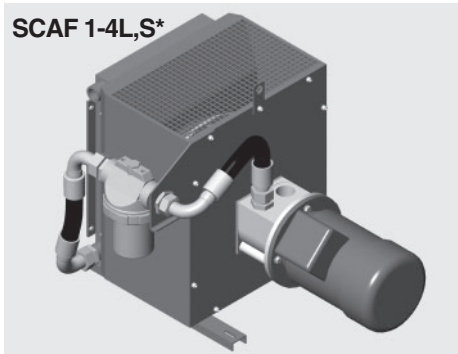

SCAF 0-4

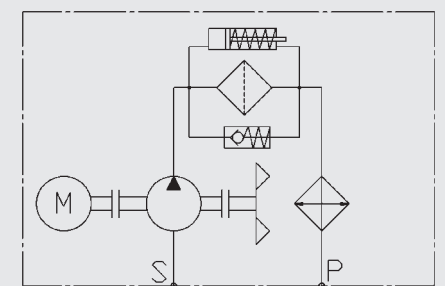

For SC size 0, see page 6

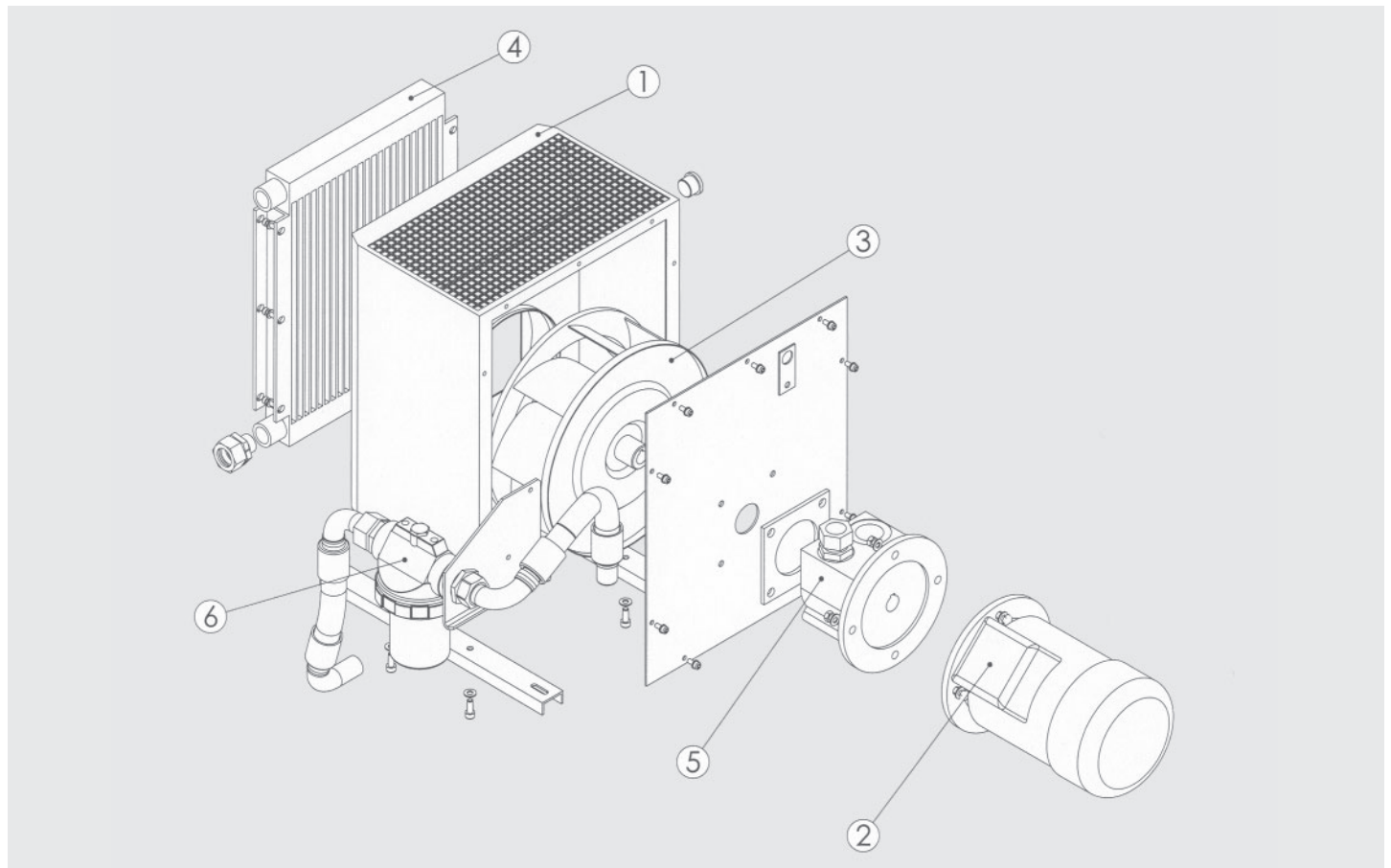

COOLER SELECTION

Designation:

P_v = Power loss [kW]

P_{01} = Specific cooling capacity [kW/°C]

V = Tank contents [l]

ρ_{oil} = Density of the oil [kg/l]
for mineral oil: 0.915 kg/l

C_{oil} = Specific heat capacity [kJ/kgk]
for mineral oil 1.88 kJ/kgk

ΔT = Temperature increase in the system [°C]

t = Operating time [min]

T_1 = Recommended oil temperature [°C]

T_3 = Ambient temperature [°C]

Example 1:

Measurement of the power loss on existing units and machinery. For this method the temperature increase of the oil is measured over a certain period. The power loss can be calculated from the temperature increase.

Parameters:

The oil temperature increases from 20 °C to 45 °C over 15 minutes.

The tank contains 100 l.

Heat to be dissipated:

$$P_v = \frac{\Delta T \times c_{oil} \times \rho_{oil} \times V}{t \times 60} \quad [\text{kW}]$$

$$P_v = \frac{25 \times 1.88 \times 0.915 \times 100}{15 \times 60} = 4.78 \quad [\text{kW}]$$

Cooler selection:

– Desired oil temperature: 60 °C
– Ambient temperature air: 30 °C

$$P_{01} = \frac{P_v}{T_1 - T_3} \quad [\text{kW}/^\circ\text{C}]$$

$$P_{01} = \frac{4.78}{60 - 30} = 0.159 \quad [\text{kW}/^\circ\text{C}]$$

A 10% safety margin is recommended to allow for element contamination, and therefore the specific power is:

$$P_{01} \times 1.1 = 0.175 \text{ kW}/^\circ\text{C}.$$

The power loss 0.175 kW/°C must be dissipated by an oil cooler.

Suggestion:

–Cooler SCA 2S/28/...,

P_{01} 0.195 kW/K at 36 l/min.

Example 2:

The power loss can also be estimated: With unrestricted flow approx. 15 to 20% of the drive power. With restricted flow up to 30% of the drive power.

1. TECHNICAL DETAILS

1.1 TABLE OF TECHNICAL SPECIFICATIONS

Type of cooler	Displacement [cm³/U]	Oil flow [l/min]	N° of poles [-] / size [-]	Motor capacity [kW]	Noise level [dB(A)] at 1m distance at 50/60Hz	Max. operating pressure [bar]	Max. oil temperature [°C]	Max. Viscosity [mm²/s]	Size of filter [-]	Weight [kg]
SC 0S	–	* 60	4/71	0.18	61/64	16	130	2000	–	14
SCA 0S	10	13	4/71	0.37	65/72	6	80	180	–	18
SCAF 0S	10	13	4/71	0.37	65/72	6	80	180	LF60	23
SC 1L	–	* 120	6/71	0.25	60/62	16	130	2000	–	21
SC 1S	–	* 120	4/71	0.25	65/69	16	130	2000	–	21
SCA 1L	10	8.5	6/71	0.25	60/63	6	80	180	–	25
SCA 1S	10	13	4/71	0.37	66/70	6	80	180	–	25
SCAF 1L	10	8.5	6/71	0.25	60/63	6	80	180	LPF160	31
SCAF 1S	10	13	4/71	0.37	66/70	6	80	180	LPF160	31
SC 2L	–	* 120	6/80	0.37	60/63	16	130	2000	–	32
SC 2S	–	* 120	4/80	0.55	70/74	16	130	2000	–	32
SCA 2L	28–40	24–34	6/90	1.10	65/69	6	80	180	–	38
SCA 2S	28–40	36–52	4/90	1.50	72/75	6	80	180	–	38
SCAF 2L	28–40	24–34	6/90	1.10	65/69	6	80	180	LPF160	45
SCAF 2S	28–40	36–52	4/90	1.50	72/75	6	80	180	LPF160	45
SC 3L	–	* 160	6/80	0.55	68/72	16	130	2000	–	47
SC 3S	–	* 160	4/80	0.75	79/82	16	130	2000	–	47
SCA 3L	28–40	24–34	6/90	1.10	69/74	6	80	180	–	59
SCA 3S	28–40	36–52	4/90	1.80	80/84	**6	80	180	–	59
SCAF 3L	28–40	24–34	6/90	1.10	69/74	6	80	180	LPF160	67
SCAF 3S	28–40	36–52	4/90	1.80	80/84	**6	80	180	LPF160	67
SC 4L	–	* 160	6/80	0.55	68/72	16	130	2000	–	49
SC 4S	–	* 160	4/80	0.75	77/80	16	130	2000	–	49
SCA 4L	28–40	24–34	6/90	1.10	68/73	6	80	180	–	61
SCA 4S	28–40	36–52	4/90	1.80	79/83	**6	80	180	–	61
SCAF 4L	28–40	24–34	6/90	1.10	68/73	6	80	180	LPF160	69
SCAF 4S	28–40	36–52	4/90	1.80	79/83	**6	80	180	LPF160	69

* max oil flow

** at 60Hz max operating pressure admitted: 4 bar

- Suction vacuum at pump inlet max -0.4 bar
- For direction of rotation see arrow on cooler housing
- Mounting position: preferably horizontal
- Cooling fluid: Mineral oil to DIN 51524
For other fluids, please contact our sales/technical department
- Three-phase motors IP55 tropical insulation, conforming CE norm
- The noise levels are only a guide as acoustic properties vary and depend on the characteristics of the room, connections, viscosity and resonance.
- Noise level measured at 30 mm²/s flatted suction at pump
- Options: see accessory catalogue

Warning!

When operating a cooler in situations where the difference in temperature between ambient air and inlet oil exceed 50 Deg. Celsius, care must be taken to avoid cycling of the fan at full speed/air flow as this can cause rapid change in material temperature of element and may result in significant reduction in lifetime or direct damage to the element through thermal stress.

Please contact your Hydac Branch or distributor for speed control solutions.

1.2 HYDRAULIC DETAILS

1.2.1 Cooling capacity

depending on oil flow and the temperature differential ΔT between the oil inlet and air inlet

For calculations with low ΔT values (i.e. below 10 °C), please contact our technical support staff.

Tolerance: $\pm 5\%$

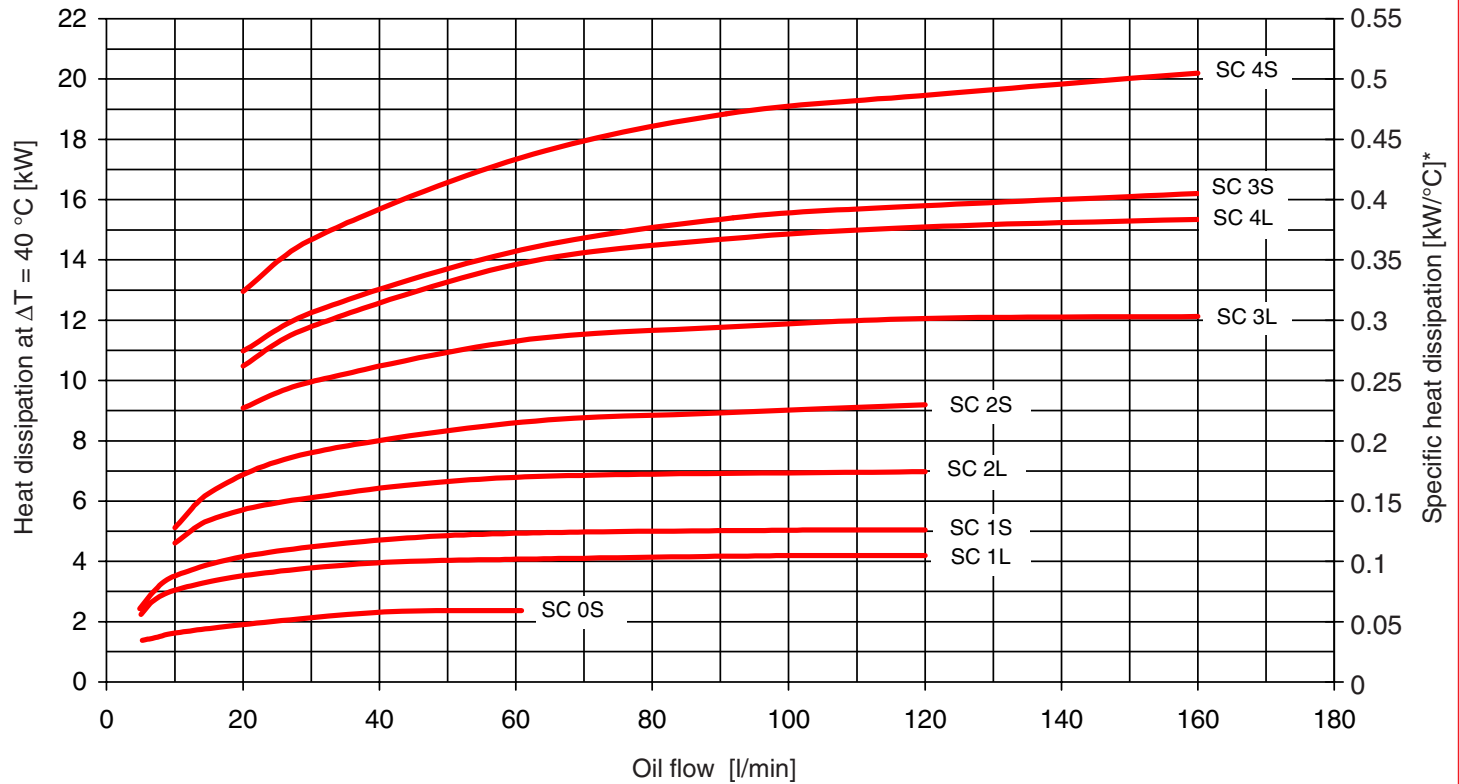

* : Values measured at $\Delta T=40\text{ °C}$, may vary at lower ΔT values

1.2.2 Pressure differential Δp measured at 30 mm²/s using mineral oil

Tolerance: $\pm 5\%$

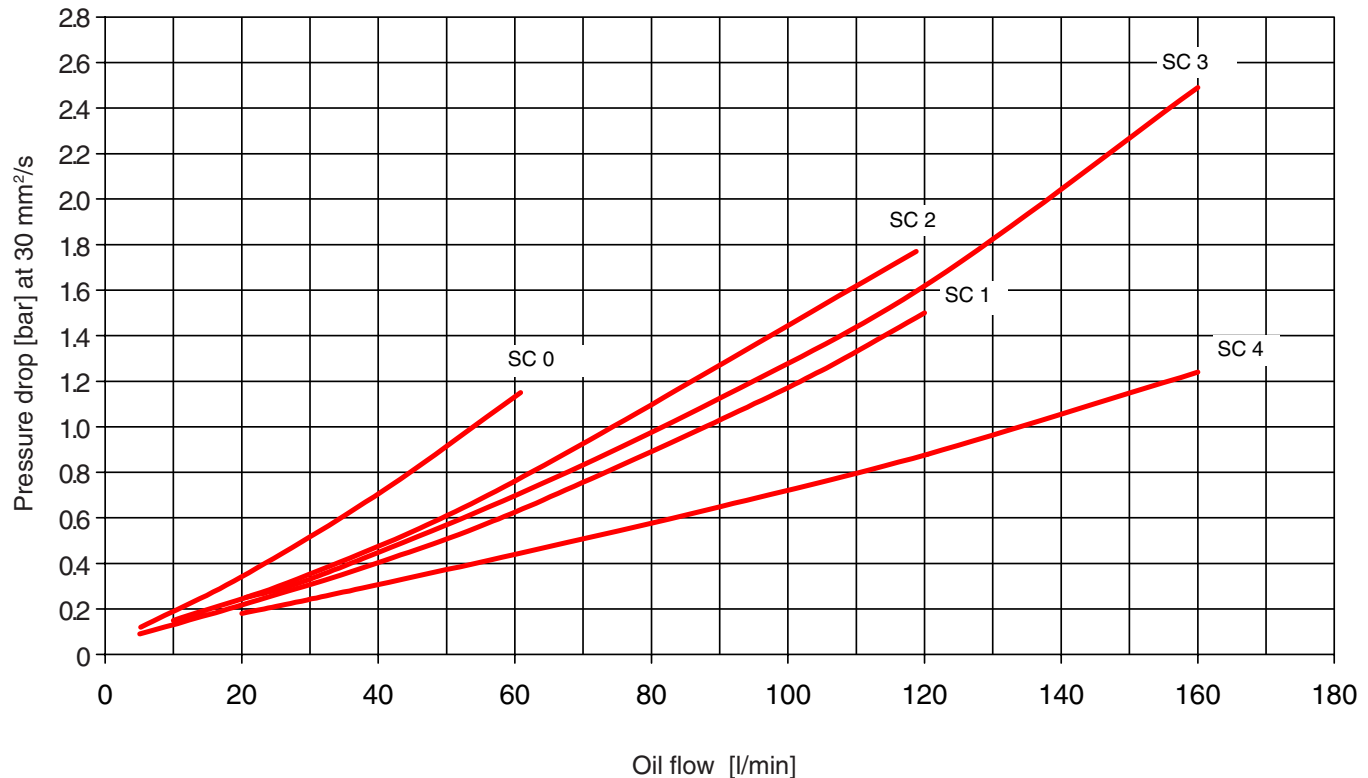

For other viscosities the pressure drop must be multiplied by K (these are indicative values only).

Viscosity (mm ² /s)	10	15	22	30	46	68	100	150
Factor K	0.35	0.5	0.75	1	1.4	1.9	2.5	3.5

2. MODEL TYPE

(also order example)

SCAF 1S / 10 / 1.0 / B / M / A / LPF160 / 4 / 1 / GP

Type of cooler

- SC = Oil/air cooler
- SCA = Oil/air cooler with built-in feed pump
- SCAF = Oil/air cooler with built-in feed pump and filter

Size / motor speed

- 0-4 = see hydraulic details 1.2
- L = 6 pl (1000 min⁻¹)
- S = 4 pl (1500 min⁻¹)

Displacement cm³/rev

- 10 = SCA/SCAF 0-1 see technical detail1.
- 28, 40 = SCA/SCAF 2-4 see technical detail1.

Type code and modification number

For the latest version of each cooler, please see the table in our internet site.

Clogging indicators (only SCAF)

- A = Without clogging indicator
- B = With visual indicator (*)
- C = With electrical indicator
- D = With electrical and optical indicator

Fluids

- M = Mineral oil to DIN 51524
- Other fluids on request

Motor voltage

- A = Standard voltages and frequencies for three-phase motor

50 Hz: 380 - 420 V (Y) / 220-240 V (Δ)
60 Hz: 440 - 480 V (Y) / 254-277 V (Δ)

Other special voltages and frequencies on request and clearly written

Size of filter (only SCAF, standard filter included 6 bar bypass valve)

- SCAF0 = LF60
- SCAF1 = LPF160
- SCAF2 = LPF160
- SCAF3 = LPF160
- SCAF4 = LPF160

Filtration rating in micron, (only SCAF)

- 8 = 5 μm Betamicon[®]-3-N (5 BN3HC)
- 4 = 10 μm Betamicon[®]-3-N (10 BN3HC) (*)
- 5 = 20 μm Betamicon[®]-3-N (20 BN3HC)

Paint

- 1 = RAL 5009 (Standard)
- Other paint on request and clearly written

Accessories (for more information see accessories brochure)

- IBT = Integrated temperature bypass valve (only available for size 1, 2 and 4)
- IBP = Integrated pressure bypass valve (only available for size 1, 2 and 4)
- AITF = Thermostat (available for the temperatures: 50, 60, 70, 80 and 95 °C)
- GP = Vibration Absorber

* Standard for SCAF unless otherwise specified.

3. DIMENSIONS

3.1. SC 0S

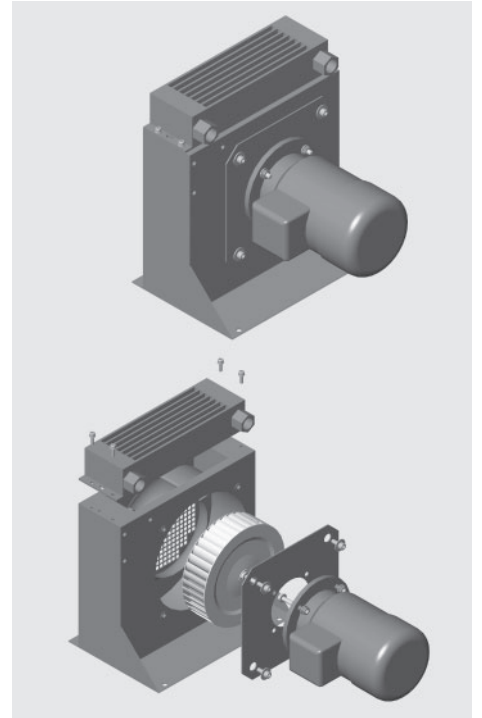
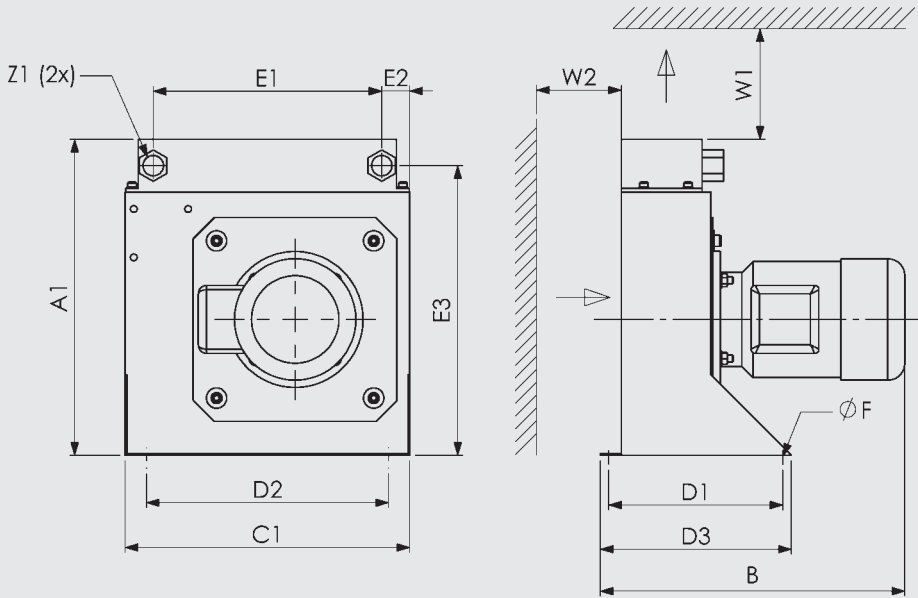

3.2. SCA 0S - SCAF 0S

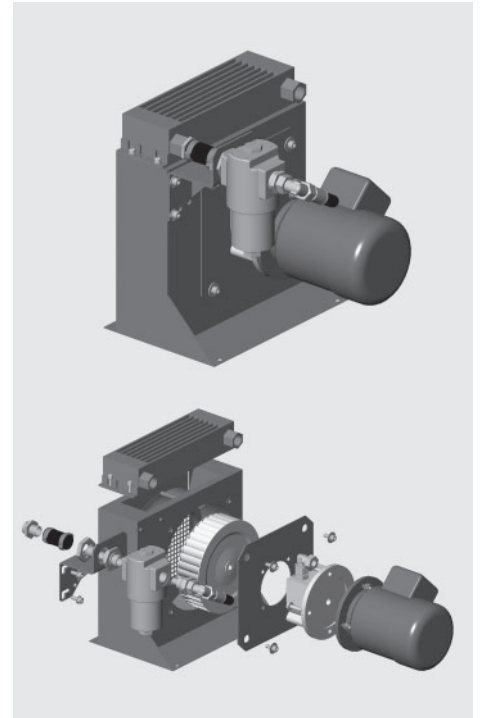
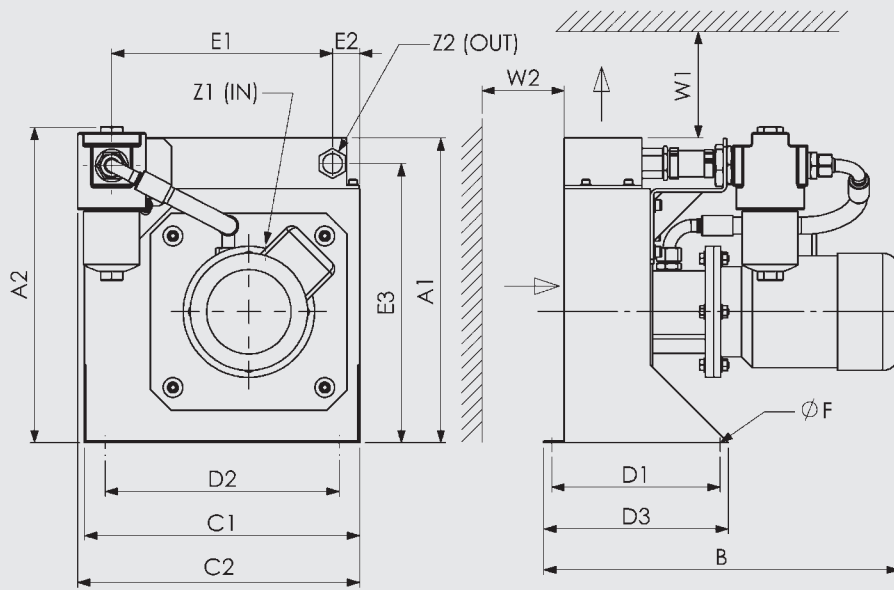

	A1	A2	B	C1	C2	D1	D2	D3	E1	E2	E3	ØF	W1	W2	Z1	Z2
	±10	±10	±10	±10	±10	±2	±2	±2	±2	±2	±2	9	min.*	min.*		
SC 0S	372	–	335	335	–	205	285	225	269	32.5	341	9	800	200	G3/4"	–
SCA 0S	372	–	433	335	–	205	285	225	269	32.5	341	9	800	200	G1/2"	G3/4"
SCAF 0S	372	386	433	335	344	205	285	225	269	32.5	341	9	800	200	G1/2"	G3/4"

* for smaller distances please contact our technical office

3.3. SC 1-4L,S

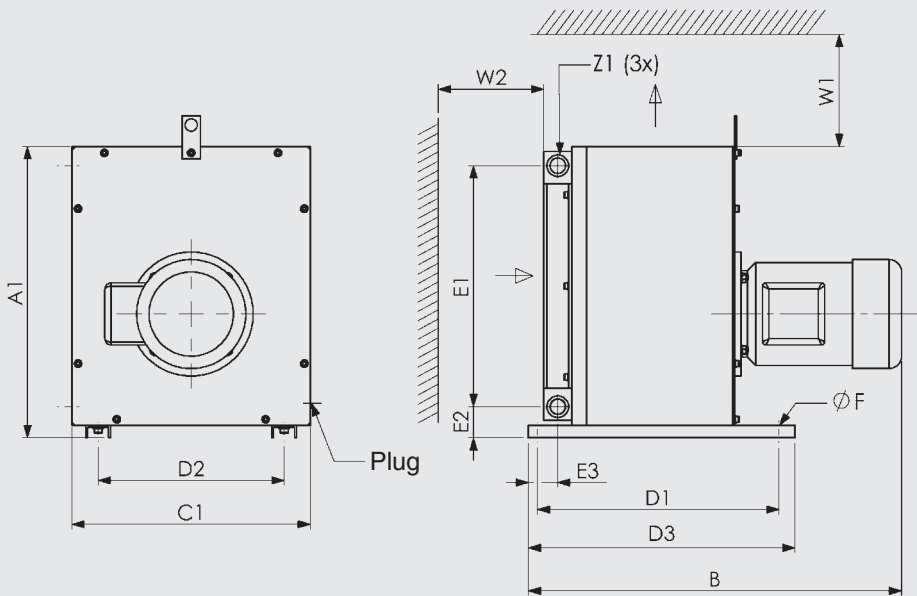

3.4. SCA 1-4L,S - SCAF 1-4L,S

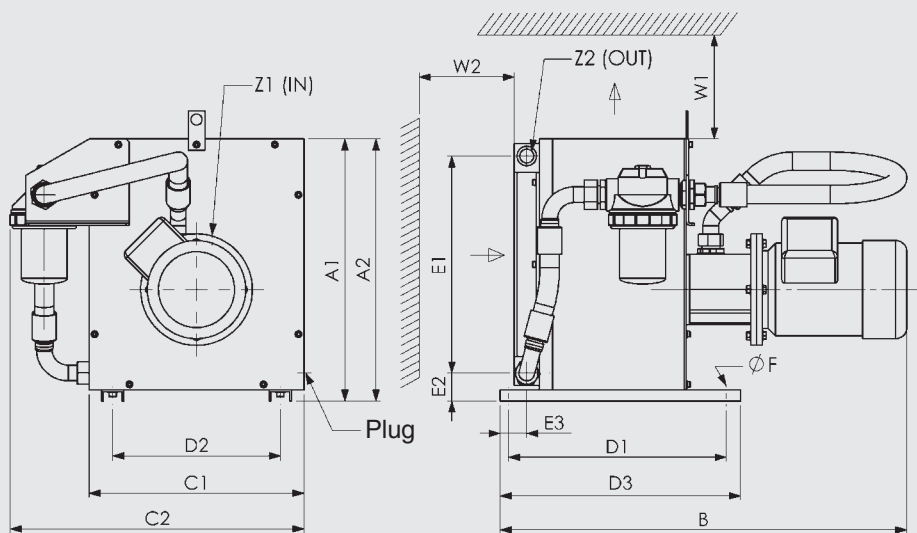

4. CERTIFICATION FOLLOWING EN 1048

Hydac SA design and manufacture high quality coolers that are tested and certified to give reliable and repeatable high performance. To ensure the performance is accurate, testing in compliance with a recognised international test standard is the best solution. For air/liquid coolers this is EN 1048.

Hydac SA test procedure complies with the requirements of EN 1048 and both the procedure and test equipment are independently inspected and certified by TÜV SÜDDEUTSCHLAND.



The cooler performance details in this brochure have been tested following EN 1048.

5. NOTE

The information in this brochure relates to the operating conditions and applications described. For applications or operating conditions not described, please contact the relevant technical department. Subject to technical modifications.

	A1	A2	B	C1	C2	D1	D2	D3	E1	E2	E3	ØF	W1	W2	Z1	Z2
	±10	±10	±10	±10	±10	±2	±2	±2	±2	±2	±2		min.*	min.*		
SC 1L,S	375	-	520	345	-	320	285	360	289	50.5	47.5	9	1000	300	G3/4"	-
SCA 1L,S	375	-	601	345	-	320	285	360	289	50.5	47.5	9	1000	300	G1/2"	G3/4"
SCAF 1L,S	375	390	601	345	486	320	285	360	289	50	47.5	9	1000	300	G1/2"	G3/4"
SC 2L,S	470	-	602	385	-	390	300	430	389	50	47.5	9	1500	400	G3/4"	-
SCA 2L,S	470	-	728	385	-	390	300	430	389	50	47.5	9	1500	400	G1 1/4"	G3/4"
SCAF 2L,S	470	500	728	385	526	390	300	430	389	50	47.5	9	1500	400	G1 1/4"	G3/4"
SC 3L,S	530	-	703	450	-	470	360	500	439	55	62.5	9	2000	500	G3/4"	-
SCA 3L,S	530	-	829	450	-	470	360	500	439	55	62.5	9	2000	500	G1 1/4"	G3/4"
SCAF 3L,S	530	560	829	450	591	470	360	500	439	55	62.5	9	2000	500	G1 1/4"	G3/4"
SC 4L,S	530	-	703	450	-	470	360	500	439	55.5	54	9	2000	500	G1"	-
SCA 4L,S	530	-	829	450	-	470	360	500	439	55.5	54	9	2000	500	G1 1/4"	G1"
SCAF 4L,S	530	560	829	450	591	470	360	500	439	55.5	54	9	2000	500	G1 1/4"	G1"

* for smaller distances please contact our technical office