

# Hydraulic Dampers

## 1. DESCRIPTION

### 1.1. GENERAL

The pressure fluctuations occurring in hydraulic systems can be periodical or one-off problems due to:

- flow rate fluctuations from displacement pumps
- actuation of shut-off and control valves with short opening and closing times
- switching pumps on and off
- sudden linking of spaces with different pressure levels

HYDAC hydraulic dampers are particularly suitable for damping such pressure fluctuations.

Selecting the most suitable hydraulic damper for each system ensures that

- vibrations caused by pipes, valves, couplings etc. are minimised and resulting pipe and valve damage is prevented
- measuring instruments are protected and their performance is no longer impaired
- the noise level in hydraulic systems is reduced
- the performance of machine tools is improved
- interconnection of several pumps in one line is possible
- a pump rpm and feed pressure increase is possible
- the maintenance and servicing costs can be reduced
- the service life of a system is increased



## 2. TYPES OF CONSTRUCTION

### 2.1. PULSATION DAMPER TYPE SB ... P

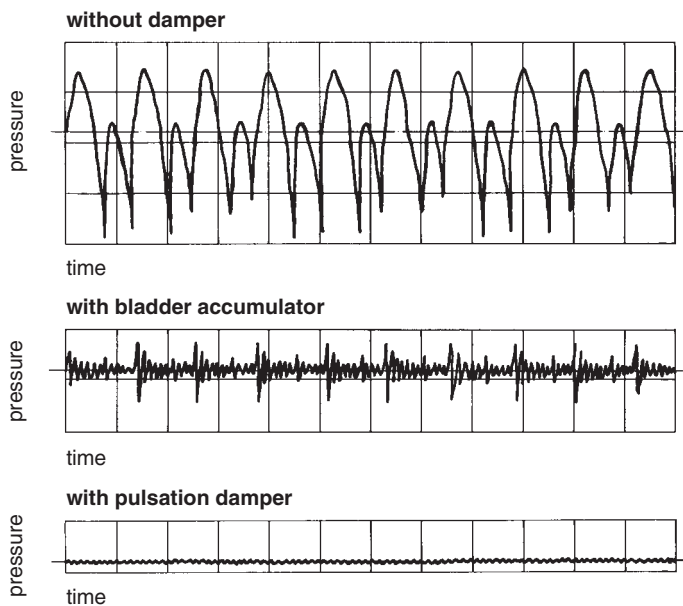

#### 2.1.1 General

The HYDAC pulsation damper

- prevents pipe breaks caused by material fatigue, pipe oscillations and irregular flow rates;
- protects valves, control devices and other instruments;
- improves noise level damping.

#### 2.1.2 Applications

The pulsation damper is particularly suited for: hydraulic systems, displacement pumps of all types, sensitive measurement and control instruments and manifolds in process circuits in the chemical industry.

#### 2.1.3 Mode of operation

The pulsation damper has two fluid connections and can therefore be fitted directly inline. The volume flow is directed straight at the bladder or diaphragm by diverting it in the fluid valve. This causes direct contact of the volume flow with the bladder or diaphragm which, in an almost inertialess operation, balances the flow rate fluctuations via the gas volume. It particularly compensates for higher frequency pressure oscillations. The pre-charge pressure is adjusted to individual operating conditions.

#### 2.1.4 Construction

The HYDAC pulsation damper consists of:

- the welded or forged pressure vessel in carbon steel; for chemically aggressive fluids with internal coating or in stainless steel;
- the special fluid valve with inline connection, which guides the flow into the vessel (threaded or flange connection);
- the bladder or diaphragm in various compounds as shown under point 5.1.

#### 2.1.5 Installation

As close as possible to the pulsation source. Mounting position preferably vertical (gas valve pointing upwards).

### 2.2. SUCTION FLOW STABILISER TYPE SB ... S

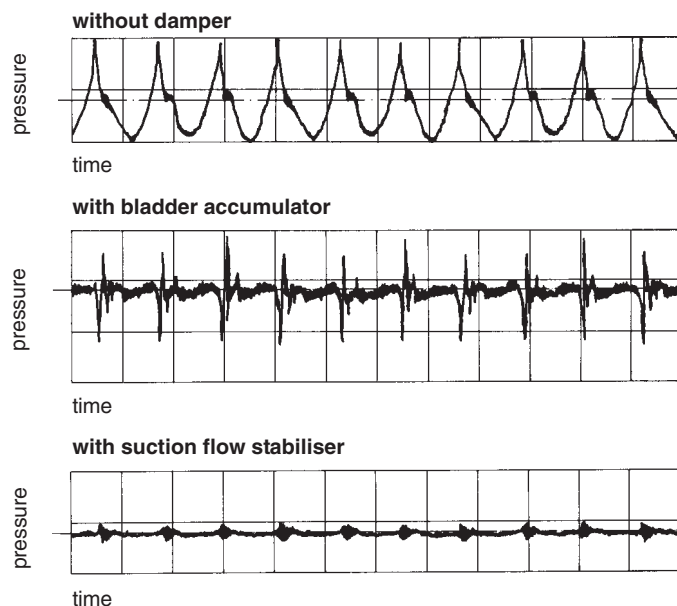

#### 2.2.1 General

The HYDAC suction flow stabiliser

- improves the NPSH value of the system;
- avoids cavitation of the pump;
- prevents pipe oscillations.

#### 2.2.2 Applications

Main application areas are piston and diaphragm pumps in public utility plants, reactor construction and the chemical industry.

#### 2.2.3 Mode of operation

Trouble-free pump operation is only possible if no cavitation occurs in the pump suction and pipe oscillations are avoided.

A relatively high fluid volume in the suction flow stabiliser in relation to the displacement volume of the pump reduces the acceleration effects of the fluid column in the suction line. Also, an air separation is achieved due to the extremely low flow rate in the suction flow stabiliser and the deflection on a baffle. By adjusting the charging pressure of the bladder to the operating conditions, the best possible pulsation damping is achieved.

#### 2.2.4 Construction

The HYDAC suction flow stabiliser consists of a welded vessel in steel or stainless steel. Inlet and outlet are on opposite sides and are separated by a baffle. The upper part houses the encapsulated bladder. In addition, there is a vent screw in the cover plate and a drainage facility on the bottom.

#### 2.2.5 Installation

As close as possible to the suction inlet of the pump. Mounting position vertical (gas valve pointing upwards).

## 2.3. SHOCK ABSORBER TYPE SB ... A

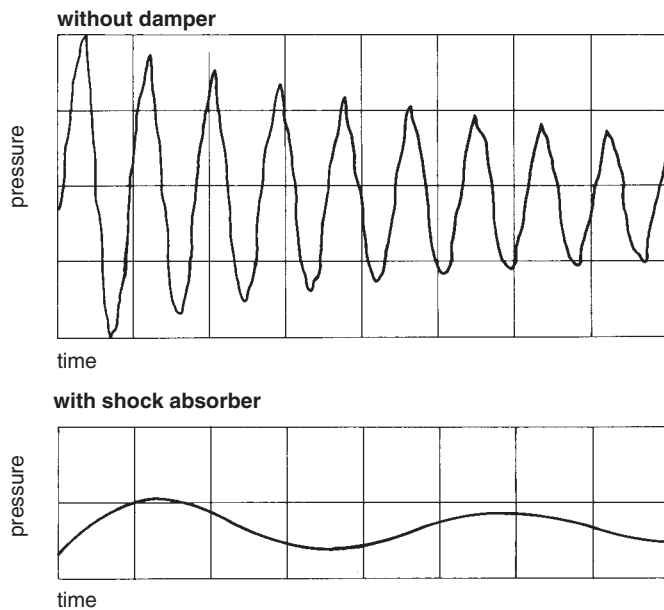

### 2.3.1 General

The HYDAC shock absorber

- reduces pressure surges;
- protects pipe lines and valves from destruction.

### 2.3.2 Applications

The accumulators are particularly suited for use in pipe lines with quick-acting valves or flaps and during switching on and switching off of pumps. They are also suitable for energy storage in low pressure applications.

### 2.3.3 Mode of operation

Sudden changes in pipe line flow, such as those caused by pump failure or the closing or opening of valves, can cause pressures which are many times higher than the normal values.

The shock absorber prevents this by converting potential into kinetic energy and vice versa. This prevents pressure surges and protects pipe lines, valves, control instruments and other devices from destruction.

### 2.3.4 Construction

The HYDAC shock absorber consists of:

- the welded pressure vessel in carbon steel with or without corrosion protection or in stainless steel;
- the connection with perforated disc which prevents the flexible bladder from extruding from the vessel, and the flange;
- the bladder in various compounds as shown under point 5.1. with built-in gas valve, which is used for charging pressure  $p_0$  and for possible monitoring activities.

### 2.3.5 Installation

As close as possible to the source of the erratic condition. Mounting position vertical (gas valve pointing upwards).

## 2.4. FLUID SILENCER TYPE SD ...

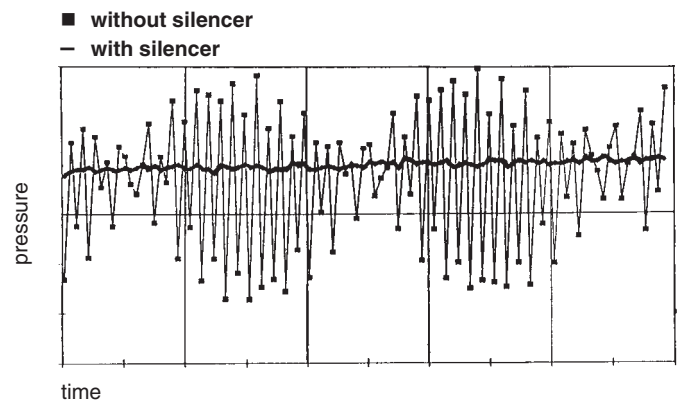

### 2.4.1 General

All displacement pumps such as axial and radial piston pumps, vane, gear or screw pumps produce volume and pressure fluctuations which show up as vibrations and noises. Noises are not only produced and transmitted by the pump but they are also the result of mechanical vibrations and vibrations caused by the fluid pulsations, which are amplified when transmitted to larger areas. Insulation, the use of flexible hoses and silencer covers can only provide partial solutions to the problem as they do not prevent transmission to other areas.

### 2.4.2 Applications

Vehicles, machine tools, plastics machinery, aeroplanes, ships, hydraulic power stations and other systems with a large "surface" are all applications where the noise level can be reduced.

### 2.4.3 Mode of operation

The HYDAC fluid silencer is based on the principle of an expansion chamber with interference line. By reflection of the oscillations within the silencer the majority of the oscillations is damped across a wide frequency spectrum.

### 2.4.4 Construction

The HYDAC fluid silencer consists of a welded or forged external housing, an internal tube and two pipe connections on opposite sides. The silencer has no moving parts and no gas charge and is therefore absolutely maintenance free. The HYDAC fluid silencer can be used for mineral oils, phosphate ester and water glycol. A stainless steel model is available for other fluids.

### 2.4.5 Installation

It is recommended that one connection side is joined via a flexible hose in order to reduce the transmission of mechanical vibrations.

The mounting position of the damper is optional, whereby the flow direction has to be taken into account.

### 3. APPROVAL SPECIFICATIONS

#### 3.1. EUROPEAN PRESSURE EQUIPMENT DIRECTIVE PED (DGRL/DEP)

On 29 November 1999 the directive 97/23/EC (Pressure Equipment Directive) came into force and has been operative since 29 May 2002.

This Directive applies to the design, manufacture, conformity assessment and circulation of pressure equipment and assemblies with a maximum permissible pressure of over 0.5 bar. It guarantees the free movement of goods within the European Community.

EU member states must not prohibit, restrict or obstruct the circulation and commissioning of pressure equipment on account of pressure-related hazards, if the equipment complies with the requirements of the pressure equipment directive and has the CE mark, and is subject to a conformity assessment.

According to Article 3 Paragraph 3, hydraulic accumulators with a capacity  $V \leq 1$  litre, a maximum permissible pressure

$PS \leq 1000$  bar and a pressure capacity  $PS \cdot V \leq 50$  bar • litre for gases of fluid group 2 (non-hazardous fluids) do not receive a CE mark.

Inspection of the equipment and installation, operational safety and repeat testing are controlled as before by national laws.

The equipment relating to safety is described in AD2000, ISO 4126 and EN 14359.

The repeat testing intervals are stipulated in the new operating safety regulations.

#### 3.2. OVERSEAS

Pressure accumulators which are installed overseas (outside the EU) are supplied with the relevant test certificates required in the country of installation. The country of installation must be stated at the time of ordering.

HYDAC pressure vessels can be supplied with virtually any test certificate. In some of these the permissible operating pressure can differ from the nominal pressure. Depending on the authority, the different material requirements must be observed.

The following table contains the codes used in the model code for different countries of installation (See Page 13).

| Country        | Certificate code |
|----------------|------------------|
| Algeria        | U <sup>3)</sup>  |
| Argentina      | U <sup>3)</sup>  |
| Australia      | F <sup>1)</sup>  |
| Bahamas        | E                |
| Barbados       | U <sup>3)</sup>  |
| Bermuda        | U <sup>3)</sup>  |
| Bolivia        | U <sup>3)</sup>  |
| Brazil         | U <sup>3)</sup>  |
| Canada         | S1 <sup>2)</sup> |
| Chile          | U <sup>3)</sup>  |
| China          | A9               |
| Costa Rica     | E <sup>3)</sup>  |
| Czech Republic | U                |
| Ecuador        | U <sup>3)</sup>  |
| Egypt          | U                |
| Hong Kong      | A9               |
| Hungary        | U <sup>3)</sup>  |
| Iceland        | U <sup>3)</sup>  |
| India          | U <sup>3)</sup>  |
| Indonesia      | U <sup>3)</sup>  |
| Iran           | U                |
| Iraq           | U <sup>3)</sup>  |
| Israel         | U <sup>3)</sup>  |
| Japan          | P                |
| Jordan         | U <sup>3)</sup>  |
| Korea          | U                |
| Kuwait         | U <sup>3)</sup>  |
| Lebanon        | U <sup>3)</sup>  |
| Libya          | U <sup>3)</sup>  |
| Malaysia       | U <sup>3)</sup>  |
| Mexico         | U <sup>3)</sup>  |
| New Zealand    | T                |
| Nigeria        | U <sup>3)</sup>  |
| Norway         | U <sup>3)</sup>  |
| Pakistan       | U <sup>3)</sup>  |
| Peru           | U <sup>3)</sup>  |
| Philippines    | U <sup>3)</sup>  |
| Poland         | U                |
| Puerto Rico    | E <sup>3)</sup>  |
| Romania        | U                |
| Russia (CIS)   | A6               |
| Saudi Arabia   | U <sup>3)</sup>  |
| Singapore      | U                |
| Slovakia       | U                |
| South Africa   | U <sup>3)</sup>  |
| Sudan          | U <sup>3)</sup>  |
| Switzerland    | U                |
| Syria          | U                |
| Taiwan         | U <sup>3)</sup>  |
| Thailand       | U <sup>3)</sup>  |
| Tunisia        | U <sup>3)</sup>  |
| Turkey         | U                |
| USA            | S                |
| Yugoslavia     | U                |

<sup>1)</sup> = approval required in the individual territories

<sup>2)</sup> = approval required in the individual provinces

<sup>3)</sup> = alternative certificates possible

#### 3.3. CERTIFICATE CODE = S

(U stamp)

HYDAC Technology GmbH in D-66280 Sulzbach/Saar is authorised (with effect from 21 August 1985) by the "National Board of Boiler and Pressure Vessel Inspectors", in conformity with the appropriate specifications of the American Society of Mechanical Engineers (ASME), to use the Code Symbol



as a stamp and for registration purposes.

#### 3.4. CERTIFICATE CODE = P

(KHK certificate)

For the Japanese market, HYDAC Technology GmbH is approved as a "self inspecting manufacturer". Therefore HYDAC is authorised to manufacture, test and import accumulators from outside Japan.

#### 3.5. CERTIFICATE CODE = A9

(Self quality licence for China)

HYDAC Technology GmbH is recognised as an importer of bladder, diaphragm and piston accumulators since 30.03.1998.

## 4. SIZING

### 4.1. DEFINITION OF VARIABLES

The compression and expansion processes are governed by the laws of polytropic change in state of ideal gases

$$p \cdot V^n = \text{constant},$$

where time is taken into account by the polytropic power "n" (ratio of specific heat capacity  $c_p/c_v$ ).

$$p_0 \cdot V_0^n = p_1 \cdot V_1^n = p_2 \cdot V_2^n$$

**Slow** expansion or compression processes occur almost **isothermally**, the polytropic power can be set at  $n = 1$ .

For **rapid** processes the **isentropic** (adiabatic) change in state applies with an isentropic exponent  $\kappa$  which is dependent on pressure and temperature (for graph, see Point 4.3.).

With the aid of the following formulae the required gas volume  $V_0$  can be calculated for various applications. In the formulae pressures always have to be used as absolute values.

$p_0$  = gas pre-charge pressure

$p_1$  = minimum working pressure

$p_2$  = maximum working pressure

$p_m$  = working pressure

$V_0$  = effective gas volume

$V_1$  = gas volume at  $p_1$

$V_2$  = gas volume at  $p_2$

$t_0$  = gas pre-charge temperature

$t_{\max}$  = max. working temperature

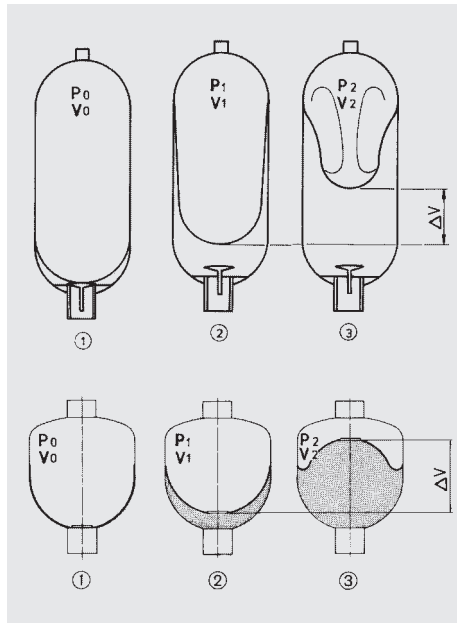

- ① The bladder (diaphragm) is pre-charged with nitrogen. The fluid valve is closed and stops the bladder (diaphragm) extruding from the shell.
- ② When the minimum working pressure is reached, there should be a small amount of fluid between bladder (diaphragm) and check valve (approx. 10 % of the nominal accumulator volume) so that the bladder (diaphragm) does not hit the valve every time it expands, as this could cause damage.
- ③ Accumulator at maximum working pressure. The volume change between the minimum and maximum working pressure corresponds to the effective fluid volume:

$$\Delta V = V_1 - V_2$$

### 4.2. SELECTION OF GAS PRE-CHARGE PRESSURES

The selection of and adherence to the gas pre-charge pressure has a considerable influence on the performance of the damper and the life expectancy of the bladder/diaphragm.

#### 4.2.1 Recommended values

Depending on the individual application, the following gas pre-charge pressure is set at maximum working temperature:

- for pulsation damping:

$$p_{0, t_{\max}} = 0.6 \div 0.8 \cdot p_m$$

for 1 piston pump:

$$p_{0, t_{\max}} = 0.6 \cdot p_m$$

for 3 or more piston pumps:

$$p_{0, t_{\max}} = 0.7 \cdot p_m$$

for working pressure range:

$$p_{0, t_{\max}} = 0.8 \cdot p_1$$

- for suction flow stabilisation:

$$p_{0, t_{\max}} = 0.6 \div 0.7 \cdot p_m$$

- for shock absorption:

$$p_{0, t_{\max}} = 0.9 \cdot p_m$$

#### 4.2.2 Critical values of the pre-charge pressure

- Hydraulic dampers with bladder:

$$p_{0, t_{\max}} = 0.9 \cdot p_1$$

with a permissible pressure ratio of  $p_2/p_0 \leq 4 : 1$

- Shock absorber:

$$p_{0, \max} = 10 \text{ bar}$$

- Hydraulic damper with diaphragm

$$p_{0, t_{\max}} \leq 0.9 \cdot p_1$$

with a permissible pressure ratio of

$$p_2/p_0 \leq 8 : 1$$

(welded construction up to 2 L nominal volume)

$$p_2/p_0 \leq 4 : 1$$

(welded construction up to 2 L nominal volume)

$$p_2/p_0 \leq 10 : 1$$

(threaded construction)

#### 4.2.3 Temperature effect

In order that the recommended gas pre-charge pressures are being maintained even at relatively high working temperatures,  $p_0, t_0$  for charging and testing cold accumulators must be selected as follows:

$$p_{0, t_0} = p_{0, t_{\max}} \cdot \frac{t_0 + 273}{t_{\max} + 273}$$

In order to take the temperature effect into account when sizing a hydraulic damper  $p_0$  at  $t_{\min}$  must be selected as follows:

$$p_{0, t_{\min}} = p_{0, t_{\max}} \cdot \frac{t_{\min} + 273}{t_{\max} + 273}$$

## 4.3. PULSATION DAMPER AND SUCTION FLOW STABILISER

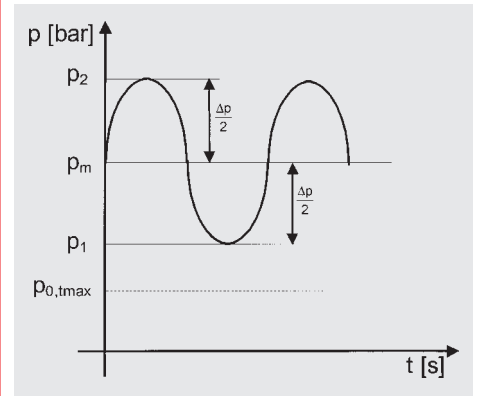
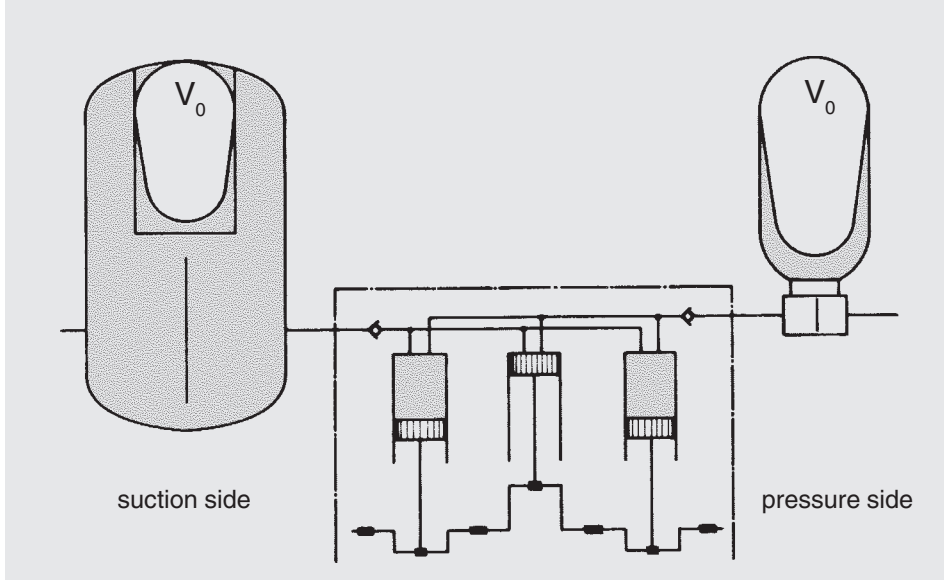

### Formulae:

$$V_0 = \frac{\Delta V}{\left( \frac{\Phi}{1 - \frac{x}{100}} \right)^{\frac{1}{\kappa}} - \left( \frac{\Phi}{1 + \frac{x}{100}} \right)^{\frac{1}{\kappa}}}$$

$$\Delta V = \delta \cdot q$$

$$x[\pm\%] = \left| \frac{p_1 - p_m}{p_m} \cdot 100 \right|$$

$$= \left| \frac{p_2 - p_m}{p_m} \cdot 100 \right|$$

### 4.3.1 Sizing

On the suction and pressure side of piston pumps almost identical conditions regarding non uniformity of the flow rate occur. Therefore the same formulae for determining the effective gas volume are used for calculating the damper size. That in the end two totally different damper types are used is due to the different acceleration and pressure ratios on the two sides.

Not only is the gas volume  $V_0$  a decisive factor but also the connection size of the pump has to be taken into account when selecting the pulsation damper. In order to avoid additional cross section changes which represent reflection points for vibrations, and also to keep pressure drops to a reasonable level, the connection cross section of the damper has to be the same as the pipe line.

The gas volume  $V_0$  of the damper is determined with the aid of the formula for adiabatic changes of state.

By giving the residual pulsation or the gas volume, the damper size can be calculated with the aid of the HYDAC **ASP** software (**A**ccumulator **S**imulation **P**rogram). The results can then be printed out or the data files can be stored in ASP format.

The ASP program is available free of charge via our website [www.hydac.com](http://www.hydac.com) or by e-mail to [speichertchnik@hydac.com](mailto:speichertchnik@hydac.com).

### Designations:

$\Delta V$  = fluctuating fluid volume [L]

$q$  = piston stroke volume [L]

$$q = \frac{\pi \cdot d_k^2}{4} \cdot h_k$$

$d_k$  = piston diameter [dm]

$h_k$  = piston stroke [dm]

$\delta$  = coefficient of cyclic variation of the pump

$z$  = no. of compressions / effective cylinders per revolution

$x$  = residual pulsation [ $\pm$  %]

$\kappa$  = isentropic exponent

$\Phi$  = pressure ratio of pre-charge pressure to operating pressure [0.6...0.9]

$$\Phi = \frac{P_0}{P_m}$$

$\Delta p$  = height of pressure fluctuations

$$\Delta p = p_2 - p_1 \text{ [bar]}$$

**Isentropic exponent  $\kappa$  dependent on pressure and temperature:**

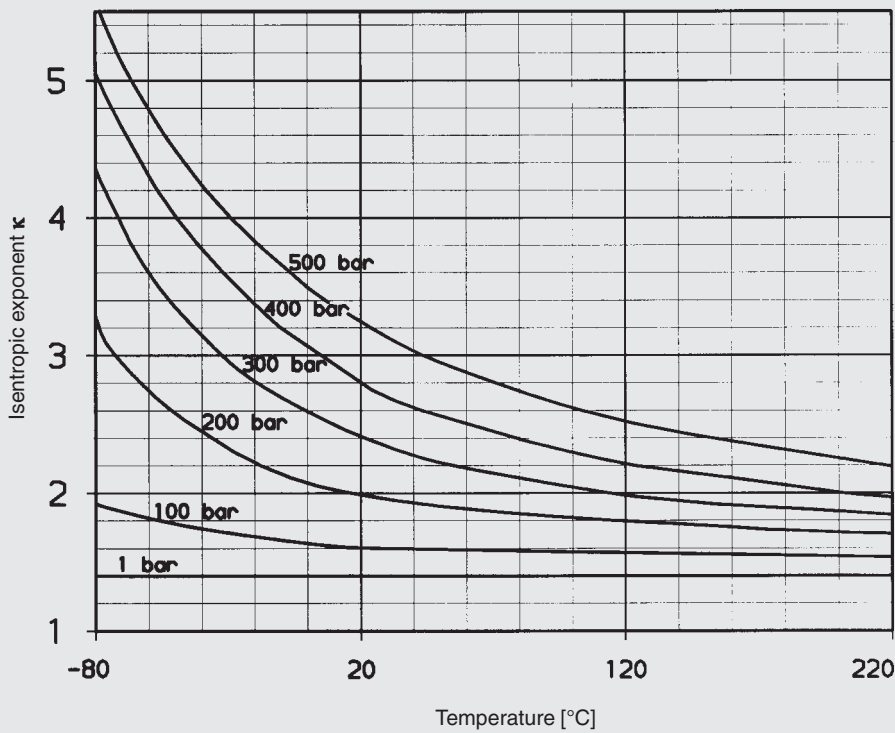

**$\delta$  values for piston pump**  
(others on request):

| z | $\delta$ - value |               |
|---|------------------|---------------|
|   | single acting    | double acting |
| 1 | 0.60             | 0.25          |
| 2 | 0.25             | 0.20          |
| 3 | 0.13             | 0.07          |
| 4 | 0.12             | 0.05          |
| 5 | 0.05             | 0.02          |
| 6 | 0.13             | 0.07          |
| 7 | 0.02             | 0.01          |
| 8 | 0.08             | 0.08          |
| 9 | 0.01             | 0.01          |

**4.3.2 Calculation example**

**Parameters:**

Single acting 3-piston pump  
 piston diameter 70 mm  
 piston stroke 100 mm  
 rpm 370 min<sup>-1</sup>  
 flow rate 244 l/min  
 operating temperature 20 °C  
 operating pressure  
 - pressure side 200 bar  
 - suction side 4 bar

**Required:**

- a) Suction flow stabiliser for a residual pulsation of  $\pm 2.5\%$
- b) Pulsation damper for a residual pulsation of  $\pm 0.5\%$

**Solution:**

- a) Determining the required suction flow stabiliser

$$V_0 = \frac{\Delta V}{\left(\frac{\Phi}{1-\frac{x}{100}}\right)^{\frac{1}{\kappa}} - \left(\frac{\Phi}{1+\frac{x}{100}}\right)^{\frac{1}{\kappa}}}$$

$$V_0 = \frac{0.13 \cdot \frac{\pi \cdot 0.7^2}{4} \cdot 1.0}{\left(\frac{0.6}{1-\frac{2.5}{100}}\right)^{\frac{1}{1.4}} - \left(\frac{0.6}{1+\frac{2.5}{100}}\right)^{\frac{1}{1.4}}}$$

$V_0 = 2.0$  L

**Selected:** SB16S-25

- b) Determining the required pulsation damper

$$V_0 = \frac{\Delta V}{\left(\frac{\Phi}{1-\frac{x}{100}}\right)^{\frac{1}{\kappa}} - \left(\frac{\Phi}{1+\frac{x}{100}}\right)^{\frac{1}{\kappa}}}$$

$$V_0 = \frac{0.13 \cdot \frac{\pi \cdot 0.7^2}{4} \cdot 1.0}{\left(\frac{0.7}{1-\frac{0.5}{100}}\right)^{\frac{1}{2.0}} - \left(\frac{0.7}{1+\frac{0.5}{100}}\right)^{\frac{1}{2.0}}}$$

$V_0 = 11.9$  L

**Selected:** SB330P-13

## 4.4. SHOCK ABSORBER

Pressure surge produced when a valve is closed without a hydraulic accumulator

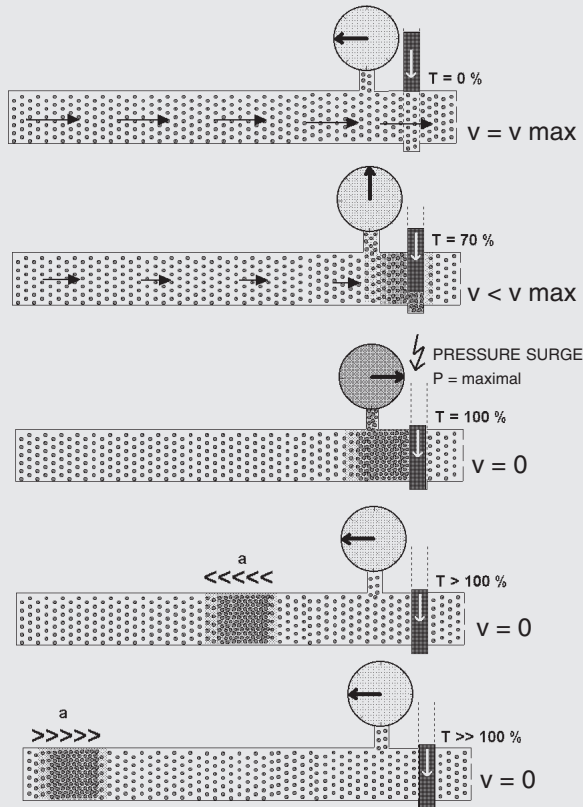

### Determining the required damper size

The accumulator must absorb the kinetic energy of the fluid by converting it into potential energy within the pre-determined pressure range. The change of state of the gas is adiabatic in this case.

$$V_0 = \frac{m \cdot v^2 \cdot 0.4}{2 \cdot p_1 \cdot \left[ \left( \frac{p_2}{p_1} \right)^{\frac{1}{\kappa}} - 1 \right] \cdot 10^2} \cdot \left( \frac{p_1}{p_0} \right)^{\frac{1}{\kappa}}$$

- $m$  (kg) = weight of fluid in the pipe line
- $v$  (m/s) = speed of fluid
- $p_1$  (bar) = zero feed height of pump
- $p_2$  (bar) = permissible working pressure
- $p_0$  (bar) = pre-charge pressure

A special calculation programme to analyse the pressure curve is available for sizing during pump failure or start-up and for manifolds.

### 4.4.1 Calculation

Simplified pressure surge calculation for the closing of a valve.

#### Estimate of Joukowsky's max. occurring pressure surge

$$\Delta p (\text{N/m}^2) = \rho \cdot a \cdot \Delta v$$

$\rho$  (kg/m<sup>3</sup>) = fluid density

$$\Delta v = v - v_1$$

$\Delta v$  = change of the fluid speed

$v$  (m/s) = speed of the fluid before the change in its condition

$v_1$  (m/s) = speed of the fluid after the change in its condition

$a$  (m/s) = velocity of the pressure wave propagation

$$a (\text{m/s}) = \frac{1}{\sqrt{\rho \cdot \left( \frac{1}{K} + \frac{D}{E \cdot e} \right)}}$$

$K$  (N/m<sup>2</sup>) = compression modulus of the fluid

$E$  (N/m<sup>2</sup>) = modulus of elasticity of the pipe line

$D$  (mm) = internal diameter of pipe line

$e$  (mm) = wall thickness of pipe line

The pressure wave runs to the other end of the pipe line and will reach the valve again after time  $t$  (reflection time), whereby:

$$t (\text{s}) = \frac{2 \cdot L}{a}$$

$L$  (m) = length of the pipe line

$T$  (s) = effective operating time (closing) of the valve

If  $T < t$ :

$$p_{\text{max}} = p_1 + \Delta p$$

If  $T > t$ :

$$p_{\text{max}} = p_1 + \rho \cdot a \cdot \Delta v \cdot \frac{t}{T}$$

#### 4.4.2 Calculation example

Quick closing of a shut-off valve in a re-fuelling line.

##### Parameters:

Length of pipe line L:  
2000 m

NW of pipe line D:  
250 mm

Wall thickness of pipe line e:  
6.3 mm

Material of pipe line:  
steel

Flow rate Q:  
432 m<sup>3</sup>/hr = 0.12 m<sup>3</sup>/s

Density of medium ρ:  
980 kg/m<sup>3</sup>

Zero feed height of pump p<sub>1</sub>:  
6 bar

Min. operating pressure p<sub>min</sub>:  
4 bar

Effective closing time of valve T:  
1.5 sec  
(approx. 20 % of the total closing time)

Operating temperature:  
20 °C

Compression modulus of the fluid K:  
1.62 • 10<sup>9</sup> N/m<sup>2</sup>

Elasticity modulus (steel) E:  
2.04 • 10<sup>11</sup> N/m<sup>2</sup>

##### Required:

Size of required shock absorber, when the max. pressure (p<sub>2</sub>) must not exceed 10 bar.

##### Solution:

Determination of reflection time:

$$a = \frac{1}{\sqrt{\rho \cdot \left( \frac{1}{K} + \frac{D}{E \cdot e} \right)}}$$

$$a = \frac{1}{\sqrt{980 \cdot \left( \frac{1}{1.62 \cdot 10^9} + \frac{250}{2.04 \cdot 10^{11} \cdot 6.3} \right)}}$$

$$a = 1120 \text{ m / s}$$

$$t = \frac{2 \cdot L}{a} = \frac{2 \cdot 2000}{1120} = 3.575 \text{ s}^*$$

\* since  $T < t$  the max. pressure surge occurs and the formula as shown under 4.4.1 must be used

$$v = \frac{Q}{A}$$

$$v = \frac{0.12}{0.25^2 \cdot \frac{\pi}{4}} = 2.45 \text{ m / s}$$

$$\Delta p = \rho \cdot a \cdot \Delta v$$

$$\Delta p = 980 \cdot 1120 \cdot (2.45 - 0) \cdot 10^{-5} = 26.89 \text{ bar}$$

$$p_{\max} = p_1 + \Delta p$$

$$p_{\max} = 6 + 26.89 = 32.89 \text{ bar}$$

Determining the required gas volume:

$$p_0 \leq 0.9 \cdot p_{\min}$$

$$p_0 \leq 0.9 \cdot 5 = 4.5 \text{ bar}$$

$$V_0 = \frac{m \cdot v^2 \cdot 0.4}{2 \cdot p_1 \cdot \left[ \left( \frac{p_2}{p_1} \right)^{\frac{1}{\kappa}} - 1 \right] \cdot 10^2} \cdot \left( \frac{p_1}{p_0} \right)^{\frac{1}{\kappa}}$$

$$\text{with } m = V \cdot \rho = \frac{\pi}{4} \cdot D^2 \cdot L \cdot \rho$$

$$V_0 = \frac{\frac{\pi}{4} \cdot 0.25^2 \cdot 2000 \cdot 980 \cdot 2.45^2 \cdot 0.4}{2 \cdot 7 \cdot \left[ \left( \frac{11}{7} \right)^{\frac{1}{1.4}} - 1 \right] \cdot 10^2} \cdot \left( \frac{7}{4.5} \right)^{\frac{1}{1.4}}$$

$$V_0 = 1641 \text{ l}$$

##### Selected:

4 off shock absorbers  
SB35AH-450.

## 4.5. SILENCER

### 4.5.1 Sizing

The sizing calculation of the HYDAC silencer is designed to result in a small unit with the best possible damping. The starting point for the selection table is to determine the level of transmission damping  $D$  from 20 dB upwards.

$$D = 20 \cdot \log \frac{\Delta p_o}{\Delta p_m}$$

$\Delta p_o$  = height of pressure fluctuations without silencer

$\Delta p_m$  = height of pressure fluctuations with silencer

For the selection of the damper the following has to be taken into account:

- 1) the size of the silencer body
- 2) the fundamental frequency  $f$  of the pump.  
 $f = i \cdot n / 60$  in Hz  
 $i$  = number of displacement elements  
 $n$  = rpm in  $\text{min}^{-1}$

### 4.5.2 Calculation example

#### Parameters:

Axial piston pump with 9 pistons  
 rpm  $1500 \text{ min}^{-1}$   
 connection G 1  
 corresponds to  $D_i = 19 \text{ mm}$   
 flow rate  $300 \text{ l/min}$   
 operating fluid: mineral oil  
 max operating pressure  $210 \text{ bar}$

#### Solution:

- 1) Fundamental frequency  $f$   
 $f = i \cdot n / 60$  in Hz  
 $= 9 \cdot 1500 / 60$   
 $= 225 \text{ Hz}$
- 2) From the "Damping curve" graph, the following silencer type can be selected:  
 SD330-S10/012U-330AE/AE  
 transmission damping  $D \approx 31 \text{ dB}$   
 Pressure drop  $\approx 2 \text{ bar}$

### 4.5.3 Damping curve

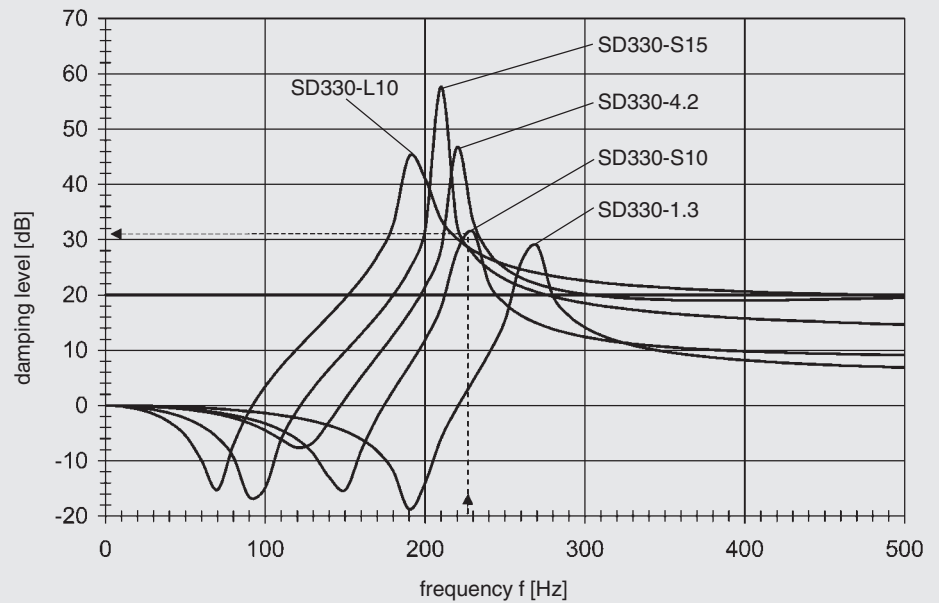

### 4.5.4 Pressure drop

#### SD330-1.3 ...

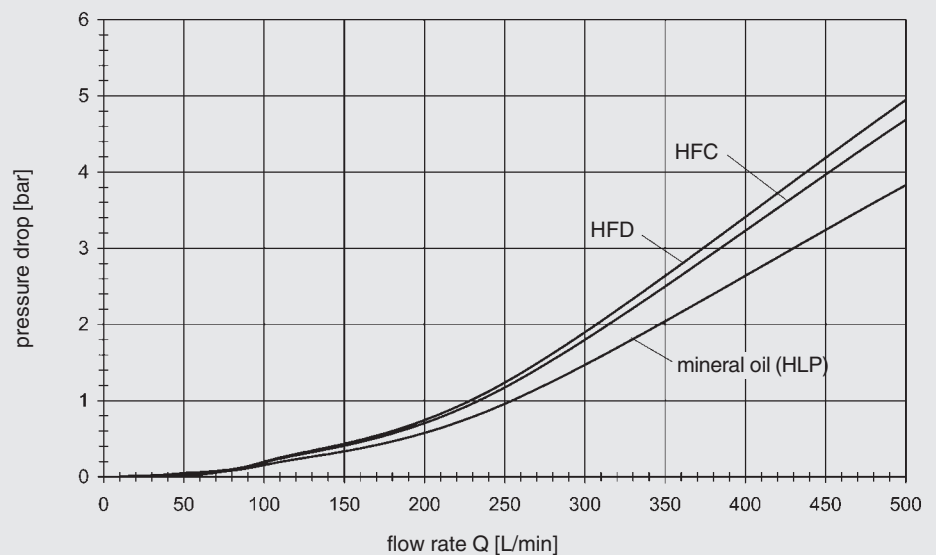

#### SD330-S10 ...

#### SD330-4.2 ...

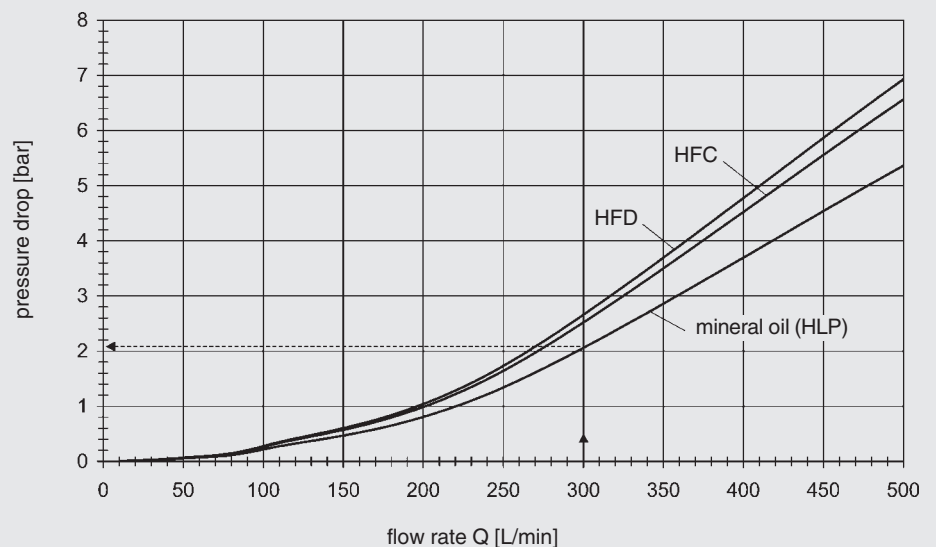

### SD330-L10 ...

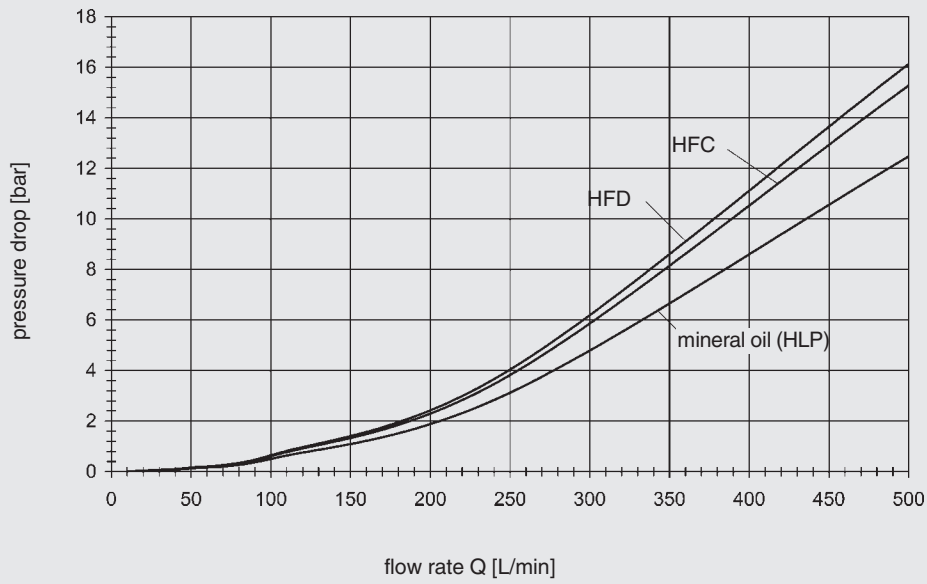

### SD330-S15 ...

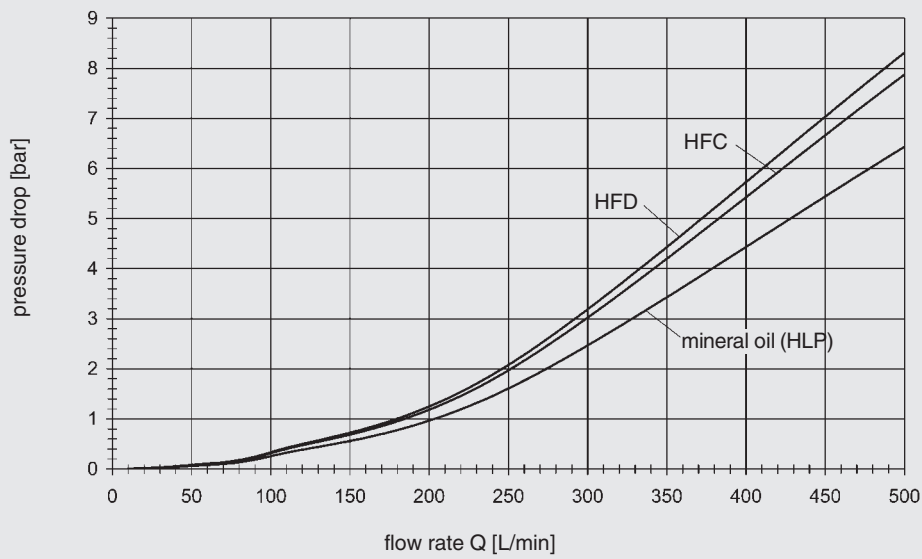

## 5. TECHNICAL SPECIFICATIONS

### 5.1. MODEL CODE

PULSATION DAMPER, SUCTION FLOW STABILISER, SHOCK ABSORBER  
(also order example)

SB 330 P - 10 A 1 / 112 U - 330 AI

#### Series

SB = with bladder  
SBO = with diaphragm

#### Type

A = shock absorber  
AH = high flow shock absorber  
P = pulsation damper  
PH = high flow pulsation damper  
S = suction flow stabiliser

#### Nominal volume in l

#### Fluid connection

A = threaded connection  
E = threaded connection for welded construction (diaphragm accumulators only)  
F = flange <sup>4)</sup>

#### Type code

1 = standard model (not for threaded construction)  
2 = back-up model <sup>1)</sup>  
6 = standard model for threaded construction diaphragm accumulators of the type SBO...P-.A6

#### Material code <sup>2)</sup>

Standard model = 112 for mineral oils depending on operating medium

#### Fluid connection

1 = carbon steel  
2 = stainless steel 1.4021 (AISI 304)  
3 = stainless steel 1.4571 (AISI 316)  
4 = chemically nickel-plated (internal coating) <sup>1)</sup>  
6 = TT-steel (low temperature)

#### Accumulator shell

0 = plastic (internal coating) <sup>1)</sup>  
1 = carbon steel  
2 = chemically nickel-plated (internal coating) <sup>1)</sup>  
4 = stainless steel 1.4571 <sup>1)</sup> (AISI 316)  
6 = TT-steel (low temperature)

#### Accumulator bladder/diaphragm <sup>3)</sup>

2 = NBR (acrylonitrile butadiene)  
3 = ECO (ethylene oxide epichlorohydrin)  
4 = IIR (butyl)  
5 = TT-NBR (low temperature)  
6 = FKM (fluoro rubber)  
7 = other (e.g. PTFE, EPDM)

#### User country <sup>2)</sup>

U = PED 97/23/EC  
for other countries see table on page 4

#### Permissible operating pressure (bar)

#### Connection thread to

AI = ISO 228 (BSP), standard connection  
BI = DIN 13 to ISO 965/1 (metric) <sup>4)</sup>  
CI = ANSI B1.1 (UNF thread, sealing to SAE standard) <sup>4)</sup>  
DI = ANSI B1.20 (NPT thread) <sup>4)</sup>

for SBO 250 P - 0.075 E1 and for SBO 210 P - 0.16 E1:

AK = ISO 228 (BSP), standard connection

<sup>1)</sup> Not available for all models

<sup>2)</sup> Not all combinations are possible

<sup>3)</sup> When ordering spare bladders, please state smallest bladder connection port size at gas charging end

<sup>4)</sup> Please give full details when ordering

## 5.2. GENERAL

### 5.2.1 Operating pressure

See tables (may differ from nominal pressure for foreign test certificates).

### 5.2.2 Nominal volumes

See tables

### 5.2.3 Effective gas volume

See tables, based on nominal dimensions. This differs slightly from the nominal volume and must be used when calculating the usable volume.

On the diaphragm accumulator, the effective gas volume corresponds to the nominal volume.

### 5.2.4 Usable volume

Volume of fluid which is available between the operating pressures  $p_2$  and  $p_1$ .

### 5.2.5 Fluids

Mineral oils, hydraulic oils, non-flam fluids, water, emulsions, fuels. Other fluids on request.

### 5.2.6 Gas charge

Use only nitrogen for charging; NEVER use oxygen (danger of explosion). When supplied, the accumulator is only pre-charged for storage purposes. Higher pre-charge pressures are possible by arrangement.

### 5.2.7 Permissible operating temperature

263 to 353 K (-10 °C to +80 °C) for material code 112.

Others on request.

### 5.2.8 Permissible pressure ratio

Ratio of maximum operating pressure  $p_2$  to gas pre-charge pressure  $p_0$  (see 4.2.2).

### 5.2.9 General safety notes

On no account must any welding, soldering or mechanical work be carried out on the accumulator shell.

After the hydraulic line has been connected it must be completely vented. Work on systems with hydraulic dampers (repairs, connecting pressure gauges etc.) must only be carried out once the pressure and fluid have been released.

**Please see operating instructions.**

## 5.3. PULSATION DAMPER

SB 330/550 P (PH)-...

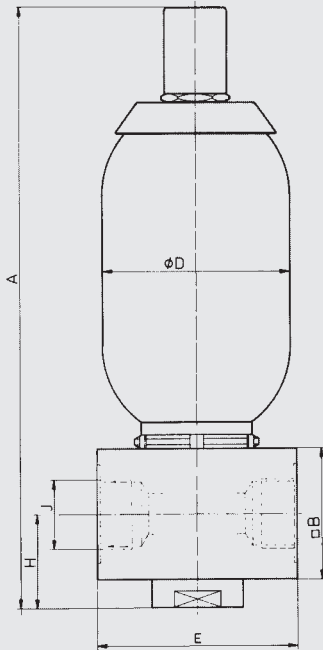

SB 800 P-...

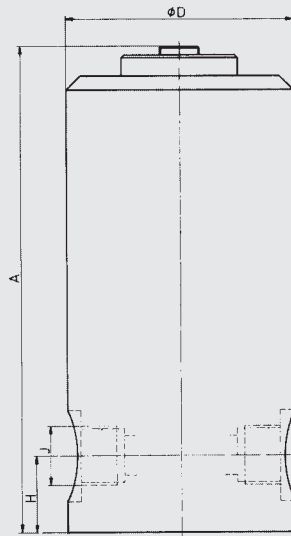

SB 1000 P-...

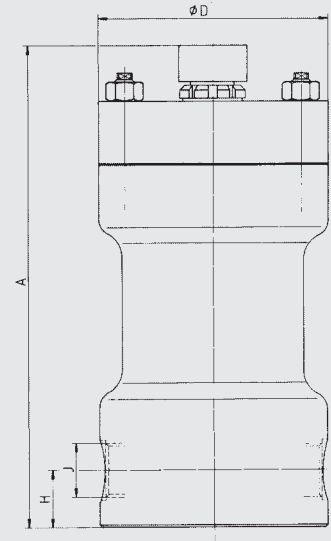

### 5.3.1 Dimensions SB

| Nominal volume litres | Max. operating pressure * bar | Effective gas volume litres | Weight kg | A mm | □ B mm  | Ø D mm | E mm    | H mm | J <sup>2)</sup> thread ISO 228 | Series         |
|-----------------------|-------------------------------|-----------------------------|-----------|------|---------|--------|---------|------|--------------------------------|----------------|
| 1                     | 330                           | 1.0                         | 11        | 365  | 80      | 118    | 120     | 57   | G 1 ¼                          | SB330P         |
|                       | 550                           |                             | 13        | 384  | 70      | 121    |         | 53   |                                | SB550P         |
| 1.5                   | 800                           | 1.3                         | 36        | 346  | –       | 160    | –       | 55   |                                | 1)             |
|                       | 1000                          |                             | 94        | 414  | –       | 215    | –       | 49   | SB1000P                        |                |
| 2.5                   | 330                           | 2.4                         | 16        | 570  | 80      | 118    | 120     | 57   | G 1 ¼                          | SB330P         |
|                       | 550                           | 2.5                         | 20        | 589  | 70      | 121    |         | 53   |                                | SB550P         |
| 4                     | 330                           | 3.7                         | 18        | 455  | 80      | 171    |         | 150  |                                | 57             |
|                       |                               |                             | 26        | 491  | 100     |        | 85      |      | SB330PH                        |                |
| 5                     | 550                           | 4.9                         | 26        | 917  | 70      | 121    | 120     | 53   | G 1 ¼                          | SB550P         |
| 6                     | 330                           | 5.7                         | 20        | 559  | 80      | 171    |         | 150  | 57                             | G 1 ½          |
|                       |                               |                             | 28        | 593  | 100     |        | 85      |      | SB330PH                        |                |
| 10                    | 330                           | 9.3                         | 40        | 620  | 130x140 | 229    | 150     | 100  | SAE2"-6000 PSI                 | SB330PH        |
|                       |                               |                             | 50        | 652  |         |        |         | 100  | 85                             | G 1 ½          |
| 13                    | 330                           | 12.0                        | 48        | 712  | 100     | 229    | 150     | 85   | G 1 ½                          | SB330P         |
| 20                    |                               | 18.4                        | 70        | 920  |         |        |         | 100  | 85                             | G 1 ½          |
|                       | 24                            | 330                         | 23.6      | 82   | 986     | 100    | 229     | 150  | 100                            | SAE2"-6000 PSI |
| 32                    |                               |                             |           | 33.9 | 100     |        |         |      | 1445                           | 85             |
|                       |                               |                             |           |      | 110     | 1475   | 130x140 |      |                                | 100            |

<sup>1)</sup> M 56 x 4, high pressure connection DN 16; others on request

<sup>2)</sup> Standard connection code = A1; others on request

\* Pressure Equipment Directive PED 97/23/EC

SBO...P...E

SBO...P...A6

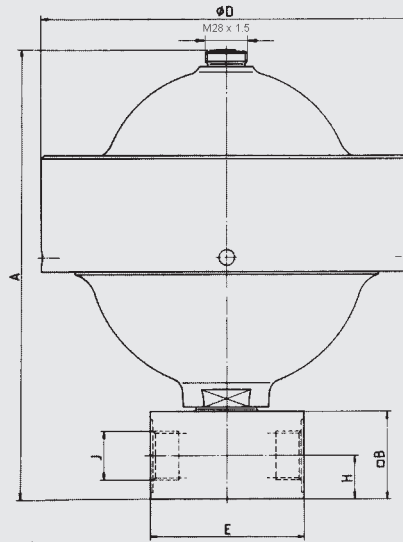
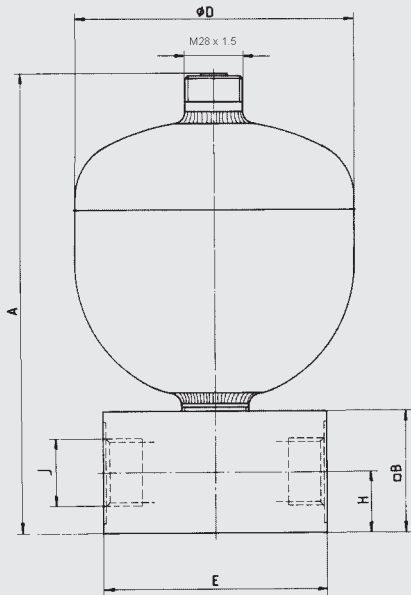

5.3.2 Dimensions SBO

| Nominal volume<br>litres | Max. operating pressure * |                     | Weight<br>kg | A<br>mm   | □ B<br>mm | Ø D<br>mm     | E<br>mm       | H<br>mm | J <sup>2)</sup><br>thread<br>ISO 228 | Series        |                       |               |
|--------------------------|---------------------------|---------------------|--------------|-----------|-----------|---------------|---------------|---------|--------------------------------------|---------------|-----------------------|---------------|
|                          | carbon steel bar          | stainless steel bar |              |           |           |               |               |         |                                      |               |                       |               |
| 0.075                    | 250                       | –                   | 0.9          | 131       | –         | 64            | hex. 41       | 13      | G ¼                                  | SBO250P-...E1 | welded construction   |               |
| 0.16                     | 210                       | 180                 | 1.0          | 143       | –         | 74            |               |         |                                      |               |                       |               |
| 0.32                     |                           | 160                 | 2.6          | 175       | 50        | 93            | 80            | 25      | G ½                                  | SBO210P-...E1 |                       |               |
| 0.5                      |                           | –                   | 2.9          | 188       |           | 104           |               |         |                                      |               |                       |               |
| 0.6                      | 330                       | –                   | 5.9          | 222       | 60        | 115           | 105           | 30      | G 1                                  | SBO330P-...E1 |                       |               |
| 0.75                     | 210                       | 140                 | 4.8          | 217       |           | 121           |               |         |                                      | SBO210P-...E1 |                       |               |
| 1.0                      | 200                       | –                   | 6.2          | 231       |           | 136           |               |         |                                      | SBO200P-...E1 |                       |               |
| 1.4                      | 140                       | –                   | 6.5          | 244       |           | 145           |               |         |                                      | SBO140P-...E1 |                       |               |
|                          | 210                       | –                   | 8.0          | 250       |           | 150           |               |         |                                      | SBO210P-...E1 |                       |               |
|                          | 250                       | –                   | 8.5          | 255       |           | 255           |               |         |                                      | SBO250P-...E1 |                       |               |
| 2.0                      | 100                       | 100                 | 6.6          | 261       |           | 160           |               |         |                                      | SBO100P-...E1 |                       |               |
|                          | 210                       | –                   | 9.2          | 267       |           | 167           |               |         |                                      | SBO210P-...E1 |                       |               |
| 3.5                      | 50                        | –                   | 13.8         | 377       |           |               |               |         |                                      | SBO50P-...E1  |                       |               |
|                          | 210                       | –                   |              |           |           |               |               |         |                                      | SBO250P-...E1 |                       |               |
| 4.0                      | –                         | 50                  | 6.0          | 368       | 158       | SBO50P-...E1  |               |         |                                      |               |                       |               |
| 0.25                     | 500                       | 350                 | 4.5 (5.2)    | 162 (180) | 50        | 115           | 80            | 25      | G ½                                  | SBO500P-...A6 | threaded construction |               |
| 0.6                      | 330                       | 250                 | 8.9 (8.4)    | 202 (215) | 60        | 140 (142)     | 95            | 105     | 30                                   | G 1           |                       | SBO450P-...A6 |
| 1.3                      | 400                       | –                   | 13.8         | 267       |           | 199           | SBO400P-...A6 |         |                                      |               |                       |               |
| 2.0                      | 250                       | 180                 | 15.6 (15)    | 285 (274) |           | 201 (199)     | SBO250P-...A6 |         |                                      |               |                       |               |
| 2.8                      | 400                       | –                   | 24.6         | 308       | 252       | SBO400P-...A6 |               |         |                                      |               |                       |               |
| 4.0                      |                           | –                   | 36.6         | 325       | 287       |               |               |         |                                      |               |                       |               |

( ) brackets indicate different dimensions for stainless steel version

<sup>2)</sup> standard connection code = A1; others on request

\* Pressure Equipment Directive PED 97/23/EC

### 5.3.3 Pulsation damper for aggressive media

#### SBO...P-...A6/347...(PTFE)

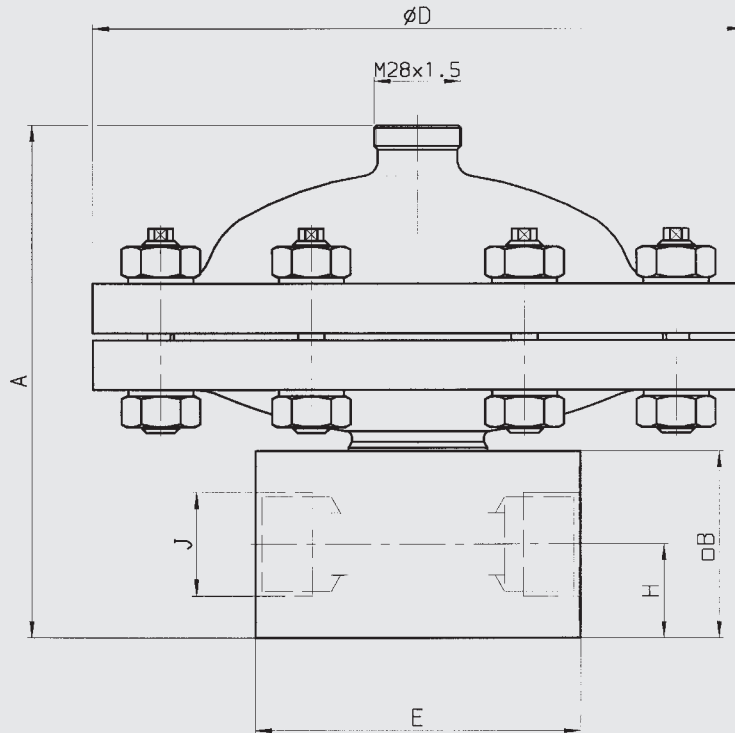

Pulsation damper in stainless steel (AISI 316) with PTFE coated diaphragm and PTFE or FFKM seals. Version in synthetic material possible on request. Also available without connection block.

Approval:  
Pressure Equipment Directive  
PED 97/23/EC

Permissible operating temperature:  
-15 / +80 °C

Permissible pressure ratio  $p_2/p_0$ :  
4 : 1

| Nominal volume<br>litres | max. operating pressure<br>bar | Weight<br>kg | A<br>mm | □ B<br>mm | Ø D<br>mm | E<br>mm | H<br>mm | J <sup>2)</sup><br>thread<br>ISO 228 |
|--------------------------|--------------------------------|--------------|---------|-----------|-----------|---------|---------|--------------------------------------|
| 0.2                      | 40                             | 11           | 140     | 60        | 210       | 105     | 30      | G 1                                  |
|                          | 250                            | 27           | 197     |           | 230       |         |         |                                      |
| 0.5                      | 40                             | 12           | 165     |           | 210       |         |         |                                      |
|                          | 250                            | 26           | 200     |           | 230       |         |         |                                      |

<sup>2)</sup> Standard connection code = AI, others on request

### 5.3.4 Spare parts

#### SB...P

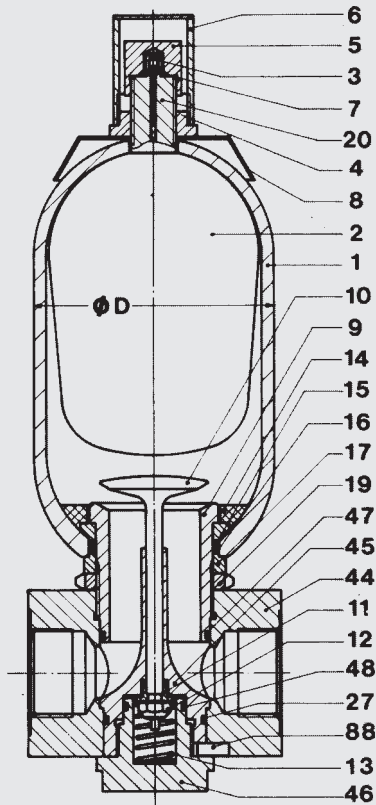

| Description           | Item |
|-----------------------|------|
| Gas valve insert *    | 3    |
| Bladder, complete *   |      |
| Bladder               | 2    |
| Gas valve insert      | 3    |
| Retaining nut         | 4    |
| Cap nut               | 5    |
| Valve protection cap  | 6    |
| O-ring                | 7    |
| Anti-extrusion ring * | 14   |
| Seal kit *            |      |
| O-ring                | 7    |
| Washer                | 15   |
| O-ring                | 16   |
| Support ring          | 23   |
| O-ring                | 27   |
| O-ring                | 47   |
| O-ring                | 48   |

\* recommended spares

| Description                         | Item |
|-------------------------------------|------|
| Connection, complete consisting of: |      |
| Oil valve body                      | 9    |
| Valve plate                         | 10   |
| Damping sleeve                      | 11   |
| Safety nut                          | 12   |
| Spring                              | 13   |
| Anti-extrusion ring                 | 14   |
| Washer                              | 15   |
| O-ring                              | 16   |
| Spacer                              | 17   |
| Lock nut                            | 19   |
| Support ring (only for 330 bar)     | 23   |
| O-ring                              | 27   |
| Connector                           | 44   |
| Guide piece                         | 45   |
| Cap                                 | 46   |
| O-ring                              | 47   |
| O-ring                              | 48   |
| Locking key                         | 88   |

#### O-ring dimensions (mm)

| Series    | Nom. volume   | Item 7 | Item 16                    | Item 27                    | Item 47                    | Item 48                    |
|-----------|---------------|--------|----------------------------|----------------------------|----------------------------|----------------------------|
| SB330P    | 1 - 6 L       | 7.5x2  | 55 x 3.5 <sup>1)</sup>     | 42.2 x 3 <sup>1)</sup>     | 46 x 3 <sup>1)</sup>       | 24.2 x 3 <sup>1)</sup>     |
| SB550P    | 1 - 5 L       | 7.5x2  | 50.17 x 5.33 <sup>1)</sup> | 37.82 x 1.78 <sup>1)</sup> | 40.94 x 2.62 <sup>1)</sup> | 23.52 x 1.78 <sup>1)</sup> |
| SB330P/PH | 10-32 L/4+6 L | 7.5x2  | 80 x 5 <sup>1)</sup>       | 57.2 x 3 <sup>1)</sup>     | 67.2 x 3 <sup>1)</sup>     | 37.2 x 3 <sup>1)</sup>     |
| SB330PH   | 10 - 32       | 7.5x2  | 100 x 5 <sup>1)</sup>      | 64.5 x 3 <sup>1)</sup>     | 84.5 x 3 <sup>1)</sup>     | 44.2 x 3 <sup>1)</sup>     |

<sup>1)</sup> For code 663 and 665 different dimensions

#### SB 800 P

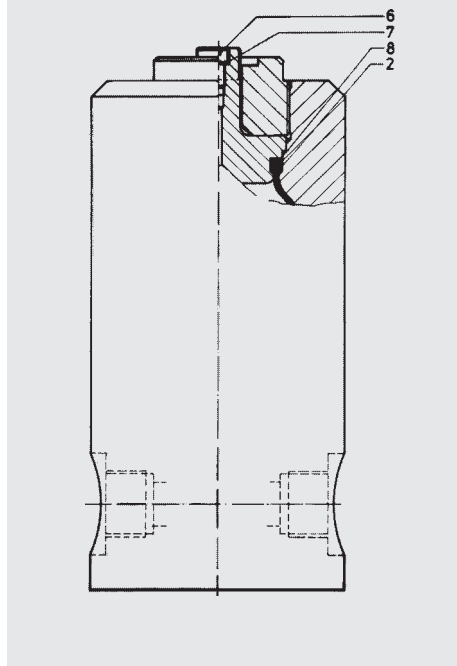

| Description                 | Item |
|-----------------------------|------|
| Bladder                     | 2    |
| Charging screw              | 6    |
| Seal ring U 9.3 x 13.3 x 1  | 7    |
| Support and sealing section | 8    |

#### SB 1000 P

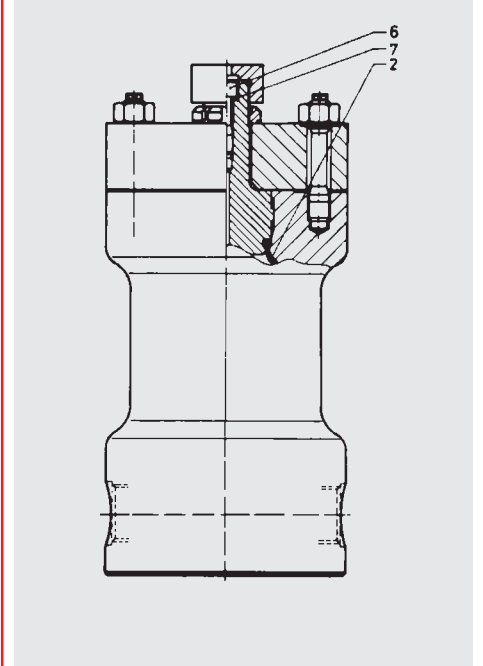

| Description    | Item |
|----------------|------|
| Bladder        | 2    |
| Charging screw | 6    |
| Seal ring      | 7    |

**SBO...P...E**

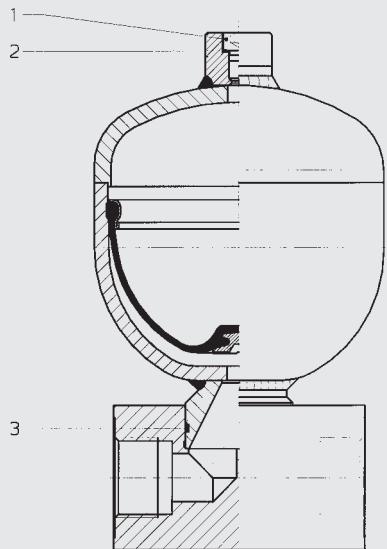

| Description    | Item |
|----------------|------|
| Charging screw | 1    |
| Seal ring      | 2    |
| Seal ring      | 3    |

**SBO...P...A6**

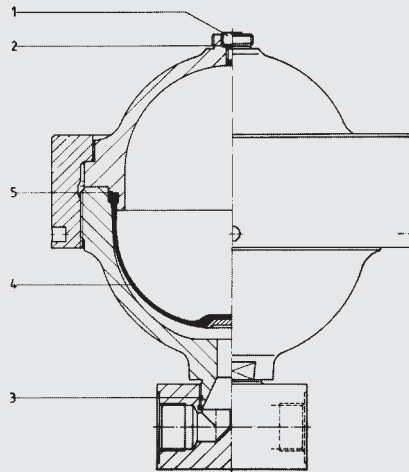

| Description    | Item |
|----------------|------|
| Charging screw | 1    |
| Seal ring      | 2    |
| Seal ring      | 3    |
| Diaphragm      | 4    |
| Support ring   | 5    |

**SBO...P...A6/347...(PTFE)**

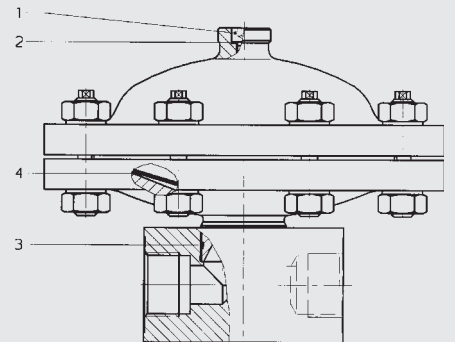

| Description    | Item |
|----------------|------|
| Charging screw | 1    |
| Seal ring      | 2    |
| Seal ring      | 3    |
| Diaphragm      | 4    |

## 5.4. SUCTION FLOW STABILISER

### SB16S

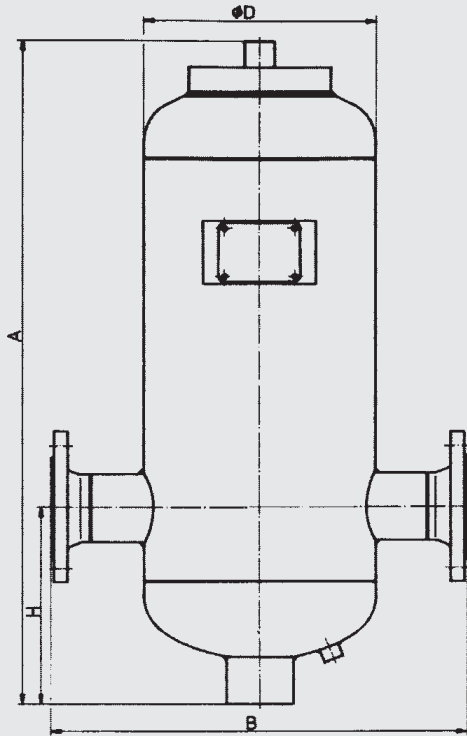

#### 5.4.1 Dimensions

##### SB 16 S - permissible working pressure 16 bar ( \* )

| Nominal volume | Fluid volume | Effective gas volume | Weight | A    | B   | Ø D | H   | DN       |
|----------------|--------------|----------------------|--------|------|-----|-----|-----|----------|
| litres         | litres       | litres               | kg     | mm   | mm  | mm  | mm  | DIN 2633 |
| 12             | 12           | 1                    | 40     | 580  | 425 | 219 | 220 | 65       |
| 25             | 25           | 2.5                  | 60     | 1025 |     |     |     |          |
| 40             | 40           | 4                    | 85     | 890  | 540 | 300 | 250 | 80       |
| 100            | 100          | 10                   | 140    | 1150 | 650 | 406 | 350 | 100      |
| 400            | 400          | 35                   | 380    | 2050 | 870 | 559 | 400 | 125      |

Further pressure ranges 25 bar, 40 bar; others on request

Other fluid volumes on request

\* Pressure Equipment Directive PED 97/23/EC

## 5.4.2 Spare parts

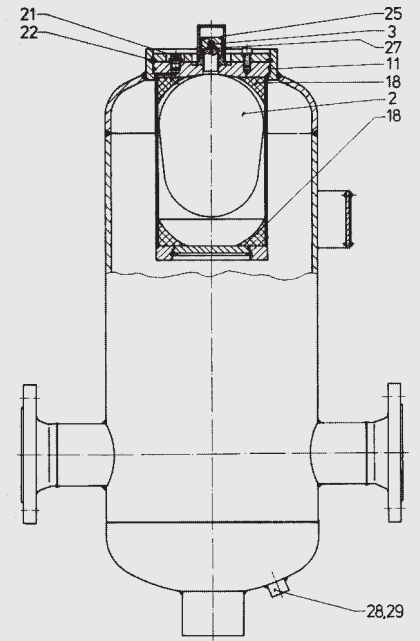

| Description        | Item |
|--------------------|------|
| Bladder            | 2    |
| Gas valve insert   | 3    |
| O-ring             | 11   |
| Insertion ring, 2x | 18   |
| Lock nut           | 21   |
| Retaining ring     | 22   |
| Cap nut            | 25   |
| O-ring             | 27   |
| Seal ring          | 28   |
| Lock nut           | 29   |

## 5.5. SHOCK ABSORBER

### SB16/35A(H)

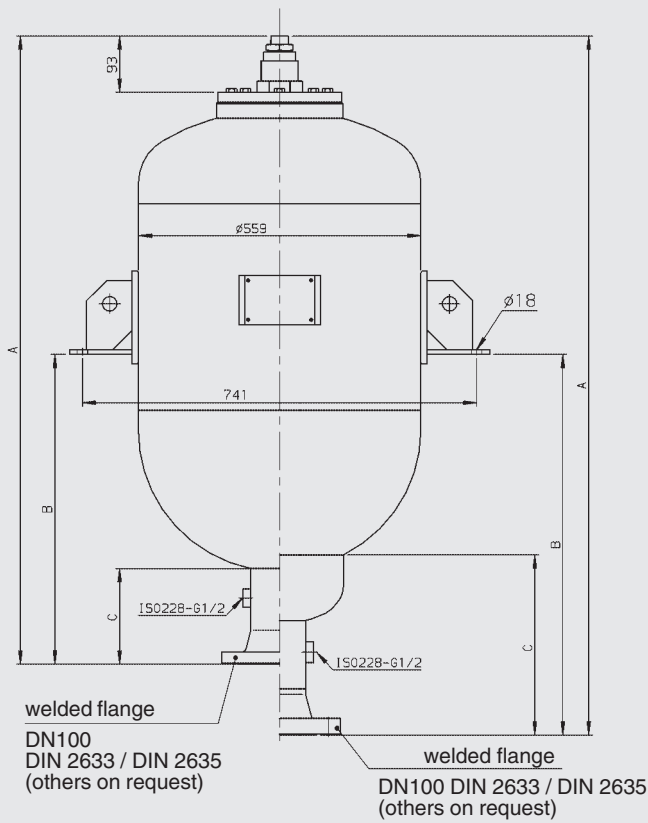

## 5.5.2 Spare parts

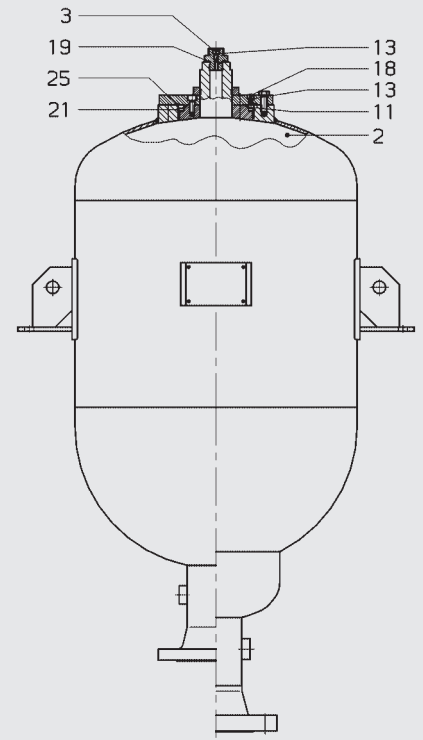

### 5.5.1 Dimensions

#### SB16/35 A - perm. working pressure 16/35 bar (PED 97/23/EC)

| Nominal volume<br>Litres | Effective volume<br>Litres | Weight<br>kg |       | A<br>(approx.)<br>mm |       | B<br>(approx.)<br>mm |       | C<br>(approx.)<br>mm |       | DN <sup>1)</sup><br>DIN 2633 |
|--------------------------|----------------------------|--------------|-------|----------------------|-------|----------------------|-------|----------------------|-------|------------------------------|
|                          |                            | SB16A        | SB35A | SB16A                | SB35A | SB16A                | SB35A | SB16A                | SB35A |                              |
| 100                      | 99                         | 84           | 144   | 870                  | 880   | 390                  | 403   | 185                  | 198   | 100                          |
| 150                      | 143                        | 101          | 161   | 1070                 | 1080  | 490                  | 503   |                      |       |                              |
| 200                      | 187                        | 122          | 223   | 1310                 | 1320  | 685                  | 698   |                      |       |                              |
| 300                      | 278                        | 155          | 288   | 1710                 | 1720  | 975                  | 988   |                      |       |                              |
| 375                      | 392                        | 191          | 326   | 2230                 | 2240  | 1250                 | 1263  |                      |       |                              |
| 450                      | 480                        | 237          | 386   | 2625                 | 2635  | 1465                 | 1478  |                      |       |                              |

#### SB16/35 AH - perm. working pressure 16/35 bar (PED 97/23/EC)

| Nominal volume<br>Litres | Effective volume<br>Litres | Weight<br>kg |        | A<br>(approx.)<br>mm |        | B<br>(approx.)<br>mm |        | C<br>(approx.)<br>mm |        | DN <sup>1)</sup><br>DIN 2635<br>DIN 2633 |
|--------------------------|----------------------------|--------------|--------|----------------------|--------|----------------------|--------|----------------------|--------|--|
|                          |                            | SB16AH       | SB35AH | SB16AH               | SB35AH | SB16AH               | SB35AH | SB16AH               | SB35AH |  |
| 100                      | 99                         | 93           | 153    | 957                  | 965    | 457                  | 465    | 245                  | 254    | 80                                       |
| 150                      | 143                        | 110          | 170    | 1157                 | 1165   | 557                  | 565    |                      |        |  |
| 200                      | 187                        | 131          | 230    | 1417                 | 1425   | 842                  | 850    |                      |        |  |
| 300                      | 278                        | 164          | 297    | 1865                 | 1873   | 1092                 | 1100   |                      |        |  |
| 375                      | 392                        | 200          | 335    | 2307                 | 2315   | 1342                 | 1350   |                      |        |  |
| 450                      | 480                        | 246          | 395    | 2702                 | 2710   | 1542                 | 1550   |                      |        |  |

<sup>1)</sup> other nominal widths on request

| Description    | Item |
|----------------|------|
| Bladder        | 2    |
| Lock nut       | 3    |
| O-ring         | 11   |
| Seal ring      | 13   |
| Vent screw     | 18   |
| O-ring         | 19   |
| Retaining ring | 21   |
| O-ring         | 25   |

## 5.6. SILENCER

SD330

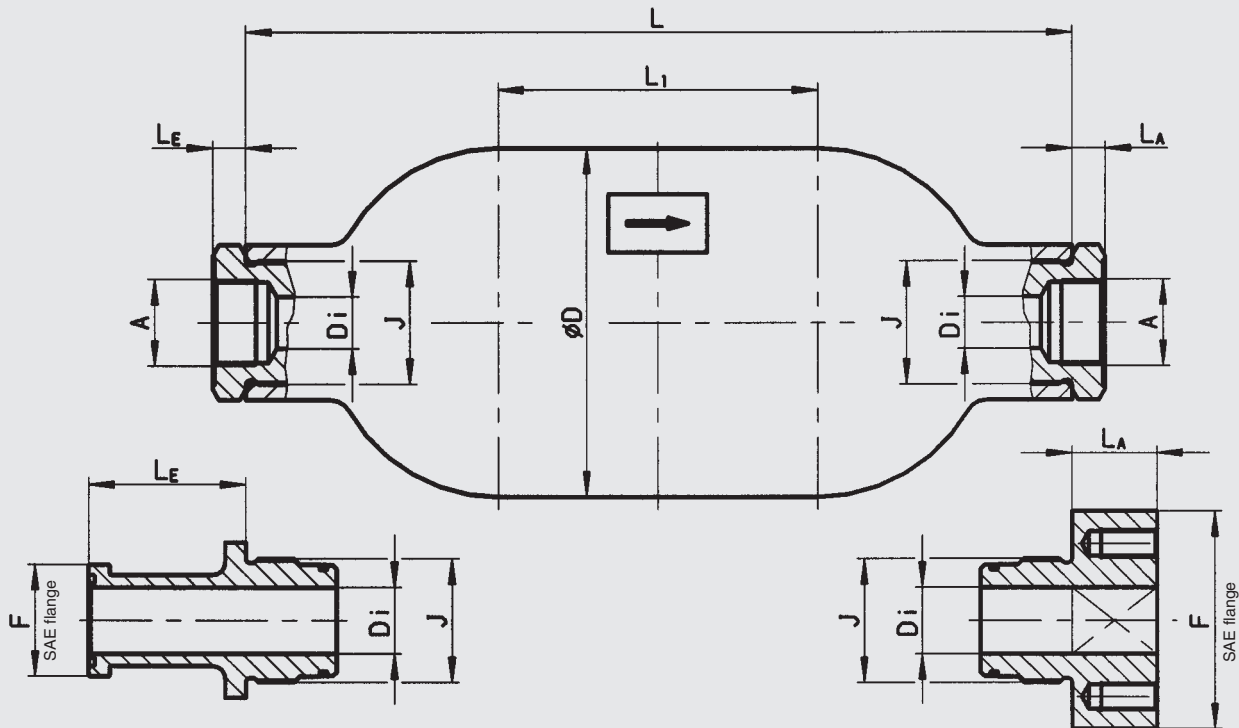

### 5.6.1 Silencer model code

SD 330 - S15 / 012 U - 330 AE/AE

**Silencer series** \_\_\_\_\_

**Size** \_\_\_\_\_

**Material code** \_\_\_\_\_

**Valve body** (not applicable) \_\_\_\_\_

**Vessel** \_\_\_\_\_  
 1 = carbon steel  
 2 = carbon steel with coating \*

**Seals** \_\_\_\_\_  
 2 = NBR (acrylonitrile butadiene)  
 6 = FPM (fluoro rubber)

**User country** \_\_\_\_\_  
 U = PED 97/23/EC  
 for other countries see table on page 4

**Permissible operating pressure (bar)** \_\_\_\_\_

**Inlet connector/outlet connector** \_\_\_\_\_  
 See table 5.6.3

\* only on request

### 5.6.2 Dimensions

| Size   | Nom. volume [L] | L [mm] | L <sub>1</sub> [mm] | Diameter D [mm] | J (ISO 228) | Weight [kg] |
|--------|-----------------|--------|---------------------|-----------------|-------------|-------------|
| 1.3    | 1.3             | 250    | -                   | 114             | G 1         | 6.5         |
| S 10   | 1.8             | 355    | 155                 |                 | G 1 ¼       | 5.5         |
| L 10 * | 5.5             | 815    | 615                 |                 |             | 14.0        |
| 4.2    | 4.2             | 346    | -                   | 168             | G 1 ½       | 12.5        |
| S 15   | 4.7             | 420    | 155                 |                 | G 2         | 11.4        |

### 5.6.3 Silencer connections

#### a) Threaded connection to ISO 228

| Size | Fluid connection A                            |                     |   |                     |   |                     |  |                     |  |                     |
|------|---|---------------------|---|---------------------|---|---------------------|--|---------------------|--|---------------------|
|      | AC<br>G ½ - ISO 228<br>D <sub>i</sub> = 13 mm |                     | AD<br>G ¾ - ISO 228<br>D <sub>i</sub> = 16 mm |                     | AE<br>G 1 - ISO 228<br>D <sub>i</sub> = 19 mm |                     | AF<br>G 1¼ - ISO 228<br>D <sub>i</sub> = 25 mm |                     | AG<br>G 1½ - ISO 228<br>D <sub>i</sub> = 32 mm |                     |
|      | L <sub>E</sub> [mm]                           | L <sub>A</sub> [mm] | L <sub>E</sub> [mm]                           | L <sub>A</sub> [mm] | L <sub>E</sub> [mm]                           | L <sub>A</sub> [mm] | L <sub>E</sub> [mm]                            | L <sub>A</sub> [mm] | L <sub>E</sub> [mm]                            | L <sub>A</sub> [mm] |
| S 10 | 13  | 13                  | 13  | 13                  | 30  | 30                  | 33   | 33                  | -  |                     |
| L 10 |   |                     |   |                     |   |                     |  |                     |  |                     |
| S 15 | -   |                     | 16  | 16                  | 16  | 16                  | 26   | 26                  | 36   | 36                  |

#### b) Flange connection SAE J518 (Code 62 - 6000 psi)

| Size | Fluid connection F                     |                     |  |                     |  |                     |   |                     |   |                     |  |                     |
|------|--|---------------------|--|---------------------|--|---------------------|---|---------------------|---|---------------------|--|---------------------|
|      | FG<br>SAE ½"<br>D <sub>i</sub> = 13 mm |                     | FH<br>SAE ¾"<br>D <sub>i</sub> = 19 mm |                     | FI<br>SAE 1"<br>D <sub>i</sub> = 25 mm |                     | FK<br>SAE 1¼"<br>D <sub>i</sub> = 32 mm |                     | FL<br>SAE 1½"<br>D <sub>i</sub> = 38 mm |                     | FM<br>SAE 2"<br>D <sub>i</sub> = 50 mm |                     |
|      | L <sub>E</sub> [mm]                    | L <sub>A</sub> [mm] | L <sub>E</sub> [mm]                    | L <sub>A</sub> [mm] | L <sub>E</sub> [mm]                    | L <sub>A</sub> [mm] | L <sub>E</sub> [mm]                     | L <sub>A</sub> [mm] | L <sub>E</sub> [mm]                     | L <sub>A</sub> [mm] | L <sub>E</sub> [mm]                    | L <sub>A</sub> [mm] |
| S 10 | 53                                     | 31                  | 59                                     | 36                  | 65                                     | 36                  | -                                       |                     | -                                       |                     | -                                      |                     |
| L 10 |  |                     |  |                     |  |                     |   |                     |   |                     |  |                     |
| S 15 | -                                      |                     | 105                                    | 36                  | 120                                    | 36                  | 76                                      | 28                  | 76                                      | 28                  | *                                      |                     |

\* on request  
- not available

#### 6. NOTE

The information in this brochure relates to the operating conditions and applications described.

For applications or operating conditions not described, please contact the relevant technical department.

Subject to technical modifications.