

Hydraulic Piston Accumulators

1. DESCRIPTION

1.1. FUNCTION

Fluids are practically incompressible and cannot therefore store pressure energy. The compressibility of a gas (nitrogen) is utilised in hydro-pneumatic accumulators for storing fluids.

HYDAC piston accumulators are based on this principle.

A piston accumulator consists of a fluid section and a gas section with the piston acting as a gas-proof screen. The gas section is pre-charged with nitrogen.

The fluid section is connected to the hydraulic circuit so that the piston accumulator draws in fluid when the pressure increases and the gas is compressed. When the pressure drops, the compressed gas expands and the stored fluid is displaced into the circuit.



1.2. CONSTRUCTION

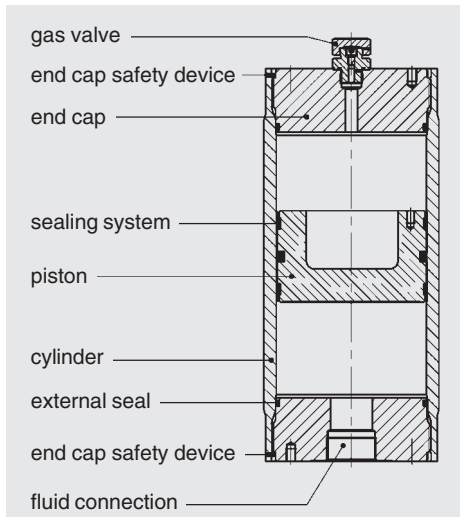

HYDAC piston accumulators consist of:

- a cylinder with very finely machined internal surface.
- end caps on the gas side and the oil side, sealed with O-rings.
- a floating light-metal piston which can easily be accelerated due to its low weight.
- a sealing system adapted to the particular application.

The piston floats on two guide rings which prevent metal-to-metal contact between the piston and the accumulator wall.

For use with certain aggressive or corrosive fluids, the parts coming into contact with the fluid can be nickel plated for protection, or made entirely from corrosion-resistant material.

Suitable materials are also available for low temperature applications.

1.3. SEALING SYSTEMS

Precise information about operating conditions is required in order to select the most appropriate sealing system. Important criteria for this selection are, for example:

- design pressure
- effective pressure differential
- switching frequency or cycles
- temperature fluctuation
- operating fluid
- cleanliness of fluid (micron rating of filter)
- maintenance requirements.

The sealing systems differ according to the type of piston used, each of which has its own type and arrangement of seals.

The following sealing materials are available, depending on the operating conditions:

- NBR/acrylonitrile butadiene rubber (PERBUNAN)
- FPM/fluoro rubber (VITON®)
- PUR/polyurethane

Standard piston Design type 1

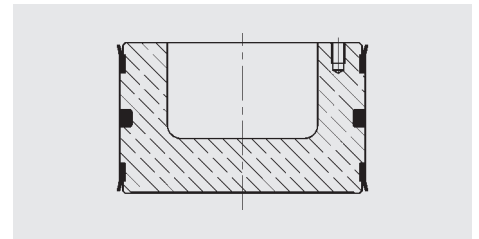

Application:

For general accumulator operation without special requirements.

Note:

Optimised for applications with a high level of contamination.

Application limitations:

Max. piston velocity: 0.5 m/s

Design type 2

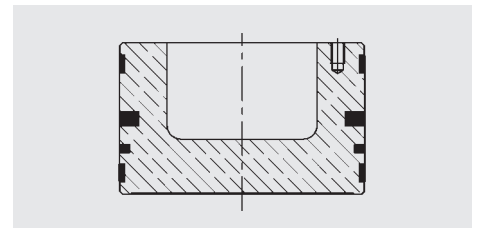

Application:

Low-friction design for high piston speeds and slow movements without stick-slip effect.

Note:

Filtration $\leq 20 \mu\text{m}$ absolute

Application limitations:

Maximum piston velocity: 3.5 m/s

Design type 3

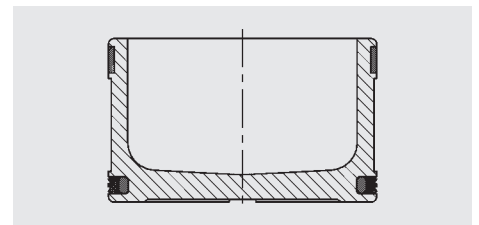

Application:

Low-friction design, simple-to-fit seals, slow movements without stick-slip effect.

Note:

Filtration $\leq 20 \mu\text{m}$ absolute

Application limitations:

Maximum piston velocity: 0.8 m/s

1.4. MOUNTING POSITION

HYDAC piston accumulators operate in any position. Vertical installation is preferable with the gas side uppermost, to prevent contamination from the fluid settling on the piston seals.

Accumulators with electrical limit switch monitoring must be mounted vertically.

1.5. ADVANTAGES OF HYDAC PISTON ACCUMULATORS

- complete range from 0.1 - 1200 l nominal volume
- high ratios possible between pre-charge pressure and max. working pressure
- economic solution using back-up gas bottles for low pressure differentials
- high flow rates possible
Limitation: max. piston velocity
- power savings
- high level of efficiency of the hydraulic installation
- gas-proof and leak-free
- no sudden discharge of gas when seals are worn
- requires little space
- monitoring of the volume across the entire piston stroke or electrical limit switch

Further advantages of using the low-friction sealing system:

- minimum friction
- also suitable for low pressure differentials
- no start-up friction
- no stick-slip
- low noise, no vibration
- high piston velocity up to 3.5 m/s for piston type 2
- improved accumulator efficiency
- good life expectancy of seals because of low wear
- suitable for large temperature fluctuations
- low maintenance requirement

1.6. TECHNICAL REQUIREMENTS

HYDAC piston accumulators are suitable for high flow rates.

With the largest extended piston diameter made so far of 800 mm, a flow rate of 1000 l/s can be achieved at a piston velocity of 2 m/s.

1.6.1 Effect of sealing friction

The permissible piston velocity depends on the sealing friction.

Higher piston velocities are possible where there is less sealing friction.

HYDAC piston accumulators of design type 2 allow velocities of up to 3.5 m/s.

1.6.2 Permissible velocities

Gas velocity

The flow velocities in the gas connection and pipe system should be limited to 30 m/s when using piston accumulators of the back-up type. Gas velocities of over 50 m/s should be avoided at all costs.

Oil velocity

In order to limit the pressure losses when the operating fluid is displaced, the flow velocity should not exceed 10 m/s in the adaptor cross-section.

1.6.3 Function tests and fatigue tests

Function tests and fatigue tests are carried out to ensure continuous improvement of our piston accumulators.

By subjecting the accumulators to endurance tests under realistic as well as extreme working conditions, important data can be obtained about the long-term behaviour of the components.

Important information on gas density and the life expectancy of the seals is gained from such tests.

Vital data for use in accumulator sizing is gained by altering the working pressure and switching cycles.

1.6.4 Fluids

The following sealing materials are suitable for the fluids listed below:

NBR, resistant to:

- mineral oil (HL and HLP)
- non-flam fluids from the group HFA, HFB and HFC
- water and seawater up to approx. 100 °C

NBR, not resistant to:

- aromatic hydrocarbons
- chlorinated hydrocarbons
- amines and ketones
- operating fluids from the group HFD

FPM, resistant to:

- mineral oils (HL and HLP)
- operating fluids from the group HFD
- fuel, as well as aromatic and chlorinated hydrocarbons
- inorganic acids (but not all, please contact our technical department)

FPM, not resistant to:

- ketones and amines
- (anhydrous) ammonia
- organic acids such as formic acid and acetic acid

PUR, resistant to:

- mineral oils (HL and HLP)
- non-flam fluids from the group HFA

PUR, not resistant to:

- water and water-glycol mixtures
- alkalis
- acids

1.6.5 Temperature ranges of the seals

Material abbrev.	HYDAC Code	Long-term temp. range
NBR	2	-20 °C...+ 80 °C
FPM	6	-15 °C...+160 °C
PUR	8	-30 °C...+ 80 °C

For temperatures outside these ranges, please contact our technical department for more information.

There are also special grades available depending on the application.

1.6.6 Gas charging

Only charge with 99.995% nitrogen, filtered to < 3 µm.

Please contact HYDAC if using other types of gases.

**Never use oxygen,
RISK OF EXPLOSION.**

1.7. PISTON POSITION INDICATORS

1.7.1 Electrical limit switch

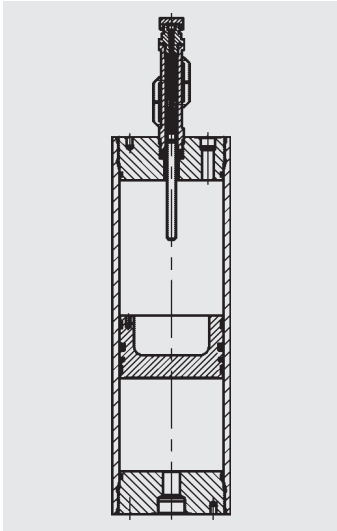

The electrical limit switch usually monitors the max. charged condition of the piston accumulator. It can, however, also permit control functions of the attached hydraulics to be carried out over a certain stroke length.

The limit switch consists of the switching rod with a permanent solenoid which is not attached to the piston and can only achieve a limited stroke, and an anti-magnetic housing and two or more switches.

These switches can be normally closed/normally open or bistable; a N/C or N/O and a bistable switch cannot be fitted simultaneously to a limit switch. Our standard limit switch is fitted with a normally closed and normally open switch.

On another model, switching is carried out by inductive proximity switches.

Reset is achieved by force of gravity, a spring or by a patented hydraulic reset mechanism (special model). The function of the limit switch is not dependent on the mounting position (with the exception of the model with gravitational reset). Vertical mounting is preferable, due to the friction and possible wear and tear in the rod guide.

The maximum piston velocity must not exceed 0.5 m/s over the stroke range of the limit switch.

1.7.2 Protruding piston rod

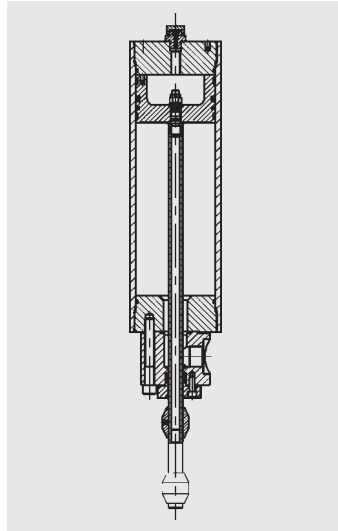

The protruding piston rod permits control of the position of the piston over the whole stroke. It consists of the piston rod, which is fixed to the piston and sealed in, and the so-called trip cam which actuates the limit switches.

The position of the piston can be monitored at any point using the trip cam. This facility is used mainly to switch the pump on and off.

Normally, the piston rod protrudes from the accumulator on the fluid side to avoid possible points of leakage on the gas side. On the protruding piston rod version the hydraulic connection will be on the side, if the size of the end cap does not permit otherwise.

The protruding piston rod functions in any mounting position. There must however be sufficient space available for the piston to move in and out.

The maximum piston velocity must not exceed 0.5 m/s over the whole stroke.

1.7.3 Ultrasonic measurement system

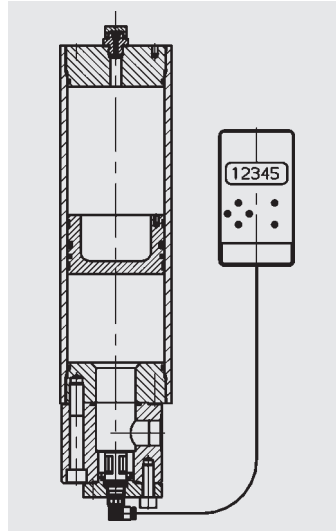

The piston position is determined by ultrasonic measurement.

It is only possible to take the measurements from the fluid side because a continuous sound carrier medium is required for the ultrasound. In order to eliminate false readings, the fluid must be as free of air bubbles as possible. The piston should be mounted so that no air can collect under the sensor.

The measurement data is evaluated by a microprocessor and is converted into a continuous measurement signal. It is possible to obtain interim measurement results to switch system parts e.g. turn the pump on and off.

The most important features of the system are:

- Protection class IP 65 according to DIN 40050
- 6 LED display
- Outputs
 - 5 floating relay switches (with 125 V, 1 A rating), of which 1 is error output, and 4 are freely adjustable switching thresholds between 0 and 100%
 - 4-20 mA

The maximum pressure on the sensor must not exceed 350 bar.

1.7.4 Cable tension measurement system

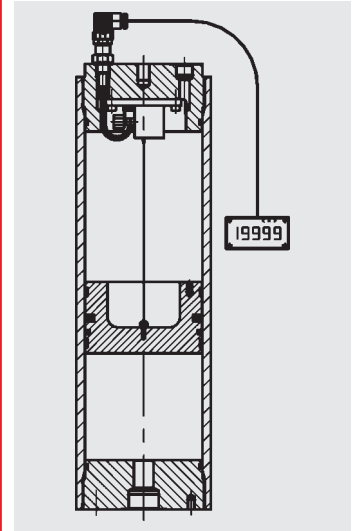

Using the cable tension measurement system, the position of the piston can be determined by means of a cable which is fixed to the piston.

The cable is attached to a wheel which is tensioned by a spring. This wheel alters an electrical resistance via an attached rotary potentiometer during the piston movement. This resistance is converted by a transducer into an electrical signal (standard: 4 .. 20 mA; optionally 0 .. 10 V) with the result that this can be processed directly by a PLC system. The signal is fed through the end cap to a pressure-tight cable gland. Alternatively a microprocessor can indicate the piston position. Up to 4 positions of the piston can also be picked up by the microprocessor to switch system parts. The electronics has the following outputs:

1. Parallel port: RS 232
2. 4 floating switching outputs.

The max. pressure must not exceed 280 bar. The piston acceleration is limited to certain values according to measurement system forces, approx. 7 .. 30 g, and is limited to a maximum velocity of 0.5 m/s. The measurement system is not suitable for high cycles and large cyclic conditions (max. cycle = 5 min⁻¹). The piston should be mounted gas side uppermost, in exceptional cases it can be mounted horizontally. The cable tension measurement system can only be fitted to the gas side of the piston accumulator.

1.7.5 Magnetic flapper indication

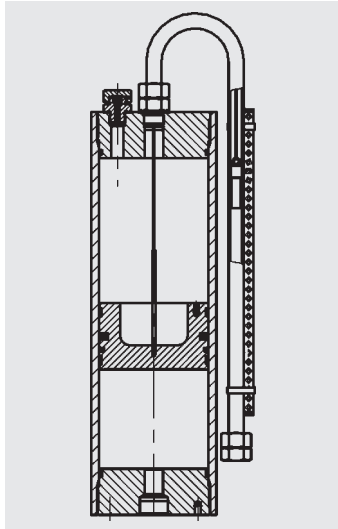

With magnetic flapper indication, the position of a piston can be determined by the colour of a set of magnetic flaps which turn as the piston moves and which are visible externally.

A non-magnetic tube is fitted to the piston accumulator containing a cable, one end of which is fastened to the gas side of the piston, and the other end is attached to a magnet. Along the length of the piston accumulator a housing is also fitted which contains red/white magnetic flappers. As the magnet moves up or down its tube, the flappers turn to their opposite colour to indicate the piston's position. In addition, reed switches can be fitted to switch system parts or measurement scales can be fitted to the tube.

The maximum piston velocity must not exceed 0.5 m/s. No more than 5 cycles per day on average should be carried out. Piston accumulators with magnetic flapper indication must only be installed vertically, gas side uppermost.

2. TECHNICAL SPECIFICATIONS

2.1. MODEL CODE
(also order example)

SK350 - 20 / 2112 U - 350 AAG - VA - 18 A - 1

Series

Nominal volume (l)

Material and piston code

Piston design type (see point 1.3)

Piston material

- 1 = aluminium
- 2 = carbon steel
- 3 = stainless steel

Material of cylinder and end caps

- 1 = carbon steel
- 2 = carbon steel with surface protection
- 3 = stainless steel
- 6 = carbon steel (low temperature)

Material of seals incl. piston

- 2 = NBR20
- 5 = NBR21 (low temperature)
- 6 = FPM (perfluoro elastomer VITON®)
- 8 = PUR (polyurethane)

Certificate code

U = PED 97/23/EC

Permissible working pressure (bar)

Fluid connection

Type of connection (see table 1)

Standard or specification of the type of connection (see tables 2 & 3)

Size of connection (see tables 4 & 5)

Gas side connection or gas valve

Type of connection (see table 1)

Standard or specification of the type of connection (see tables 2 & 3)

(no letter if type V connection)

Size of connection (see tables 4, 5 & 6)

Piston diameter

- 04 = 40 mm
- 06 = 60 mm
- 08 = 80 mm
- 10 = 100 mm
- 12 = 125 mm
- 15 = 150 mm
- 18 = 180 mm
- 20 = 200 mm
- 25 = 250 mm
- 31 = 310 mm
- 35 = 355 mm
- 49 = 490 mm

Supplementary equipment

- A = electrical limit switch - 35 mm stroke
- B = electrical limit switch - 200 mm stroke
- C = electrical limit switch - 500 mm stroke
- K = protruding piston rod
- M = magnetic flapper indication
- S = cable tension measurement system
- U = ultrasonic measurement system
- E.. = special switch (fixed and adjustable)
- P = magnetic piston

Safety devices

- 1 = burst disc (indicate nominal pressure and temperature)
- 2 = gas safety valve
- 3 = temperature fuse plug

Table 1, Connection type

Code	Description
A	Threaded connection (female)
B	Threaded connection (male)
F	Flange connection
H	Protruding flange
K	Combination connection
V	Gas valve type

Table 2, Threaded connection: standard or specification

Code	Description
A	Thread to ISO 228 (BSP)
B	Thread to DIN 13 or ISO 965/1 (metric)
C	Thread to ANSI B1.1 (UN..-2B, seal SAE J 514)
D	Thread to ANSI B1.20.3 (NPTF)
S	Special model

Table 3, Flange connection: standard or specification

Code	Description
A	Flanges to DIN standards
B	Flanges to ANSI B 16.5
C	SAE flange 3000 psi
D	SAE flange 6000 psi
E	High pressure block flange (Bosch-Rexroth) PN320
F	High pressure block flange (AVIT, HAVIT)
S	Special flange

Table 4, Threaded model connection sizes

Type	Code, size										
Tab. 2	A	B	C	D	E	F	G	H	J	K	L
A	G 1/8	G 1/4	G 3/8	G 1/2	G 3/4	G 1	G1 1/4	G1 1/2	G2	G2 1/2	G3
B	M10x1	M12x1.5	M14x1.5	M16x1.5	M18x1.5	M22x1.5	M27x2	M33x2	M42x2	M48x2	M60x2
C	5/16-24UNF	3/8-24UNF	7/16-20UNF	1/2-20UNF	9/16-18UNF	3/4-16UNF	7/8-14UNF	1 1/16-12UN	1 3/16-12UN	1 5/16-12UN	1 5/8-12UN
D	1/16-27 NPTF	1/8-27 NPTF	1/4-18 NPTF	3/8-18 NPTF	1/2-14 NPTF	3/4-14 NPTF	1-11 1/2 NPTF	1 1/4-11 1/2 NPTF	1 1/2-11 1/2 NPTF	2-11 1/2 NPTF	2 1/2-8 NPTF

Table 5, Flange model connection sizes

Type	Code, size										
Tab. 3	A	B	C	D	E	F	G	H	J	K	L
A	DN15	DN25	DN40	DN50	DN65	DN80	DN100	DN125	DN150	DN200	
B	1/2" - 1500#	1" - 1500#	1 1/2" - 1500#	2" - 1500#	2 1/2" - 1500#	3" - 1500#	1/2" - 2500#	1" - 2500#	1 1/2" - 2500#	2" - 2500#	2 1/2" - 2500#
C	1/2"	3/4"	1"	1 1/4"	1 1/2"	2"	2 1/2"	3"	3 1/2"	4"	5"
D											
E											
F	DN32	DN40	DN50	DN65	DN80	DN100	DN125	DN150			

Table 6, Gas valve models

Code	Description
A	Gas valve G3/4 male with M28x1.5/M8
B	Gas valve end connection M28x1.5/M8
C	Gas valve 1/2"-20 UNF male with M16x2 (ISO 10945)
D	Gas valve M14x1.5 male with external M16x1.5
E	Gas valve G3/4 male with 7/8-14 UNF-VG8
F	Gas valve G1/2"-20 UNF with VG8

2.1.1 Nominal volume [litres]

See table 3.1.

2.1.2 Effective gas volume V₀ [litres]

These differ slightly from the nominal volume and form the basis of the calculations of the usable volume.

The gas volume V is larger than the nominal volume given in the tables 3.1. - 3.3., by the amount given below:

Piston diameter D1 [mm]	Piston design types		
	1 [I]	2 [I]	3 [I]
60	-	-	-
80	-	0.044	0.081
100	0.091	0.091	0.270
125	-	0.257	0.563
150	-	0.655	0.823
180	0.659	0.659	1.322
200	-	0.988	2.171
250	2.531	2.531	3.573
310	-	6.168	-
355	4.434	4.434	-
490	-	12.678	-

2.1.3 Effective volume ΔV [litres]

The volume (on the fluid side) between the working pressure p₂ and p₁.

2.1.4 Permissible operating temperature (fluid)

-10 °C to +80 °C
263 K to 353 K
(standard material)
Others on request.

2.1.5 Certificate codes

Australia	F ¹⁾
Brazil	U ³⁾
Canada	S1 ²⁾
China	A9
CIS	A6
EU Member States	U ³⁾
Hungary	U ³⁾
India	U ³⁾
Japan	P
New Zealand	T
Poland	A4
Rumania	U
Slovakia	A8
South Africa	U ³⁾
Switzerland	U
USA	S
Others on request	

¹⁾ = approval required in the individual territories

²⁾ = approval required in the individual provinces

³⁾ = alternative certificates possible

Note:

Application examples, accumulator sizing and extracts from approvals regulations on hydraulic accumulators can be found in the accumulator overview brochure no. 3.000./...

3. DIMENSIONS

3.1. PISTON ACCUMULATOR

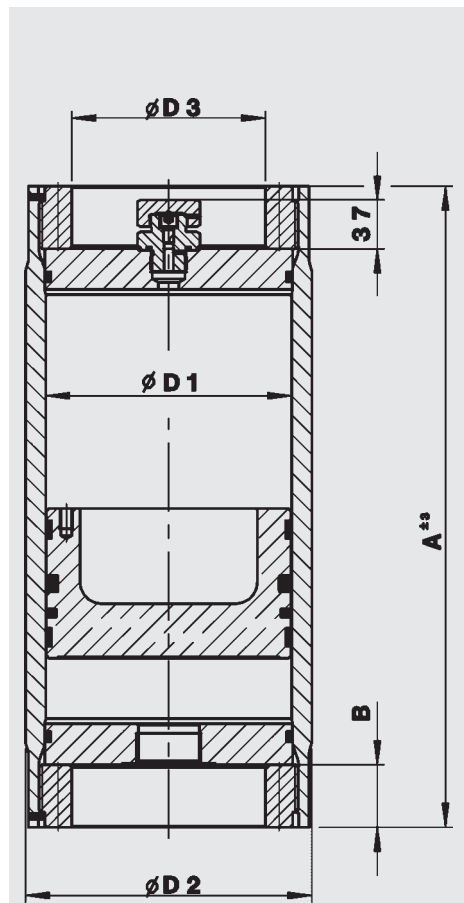

Fig. 1

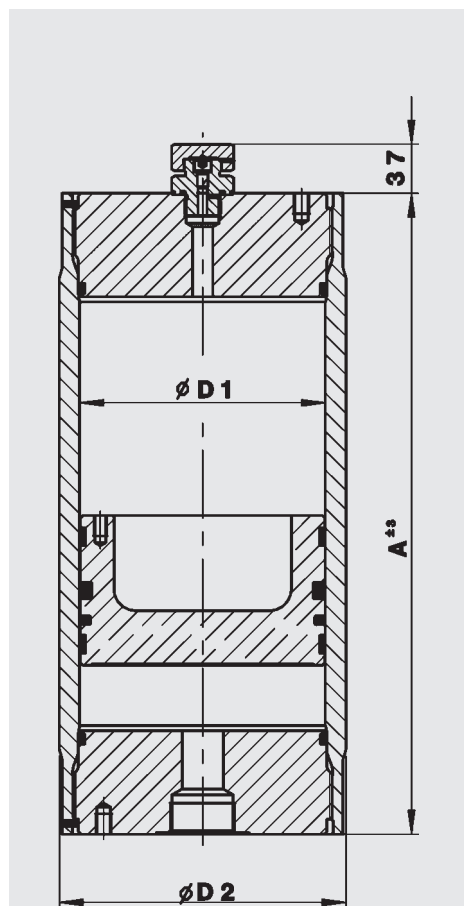

Fig. 2

Nominal ¹⁾ volume	Series	Country code U							Fig.
		ø D1	ø D2	A ±3 ²⁾	Permiss. working pressure	ø D3	B	Weight	
[litres]		[mm]	[mm]	[mm]	[bar]	[mm]	[mm]	[kg]	
0.2	SK350	60	80	195	350	-	-	6	2
0.5				305				8	
1				480				11	
0.5	SK350	80	98	255	350	-	-	10	2
1				355				12	
2				555				16	
2.5	SK350	100	126	500	350	-	-	27	2
5				820				38	
7.5				1140				50	
2	SK350	125	160	350	350	-	-	35	2
5				590				50	
15				1405				100	
6	SK350	150	180	550	350	-	-	54	2
20				1340				102	
40				2475				172	
10	SK210	180	210	655	210	-	-	69	2
	SK350		220	350	87				
20	SK210	210	1050	210	-	-	98		
	SK350	220	350	126					
50	SK210	210	2225	210	-	-	183		
	SK350	220	350	242					
20	SK350	200	235	925	350	-	-	140	2
40				1565				200	
100				3475				380	
50	SK210	250	286	1425	210	188	64	271	1; 2
	SK350		310	350	497	2			
80	SK210	250	286	2040	210	188	64	344	1; 2
	SK350		310	350	524	2			
120	SK210	250	286	2855	210	188	64	441	1; 2
	SK350		310	350	693	2			
120	SK350	310	350	2060	350	-	-	507	2
150				2450				571	
200				3115				679	
130	SK210	355	404	1845	210	285	87	717	1; 2
	SK350		434	350	1003	2			
180	SK210	355	404	2355	210	285	87	833	1; 2
	SK350		434	350	1198	2			
250	SK210	355	404	3060	210	285	87	995	1; 2
	SK350		434	350	1470	2			
200	SK350	490	580	1760	350	-	-	1773	2
400				2820				2404	
600				3880				3034	

1) Volume details are examples, others on request.

2) Intermediate sizes are possible, depending on the length/diameter required. Please contact our technical department.

3.2. PISTON WITH PROTRUDING PISTON ROD

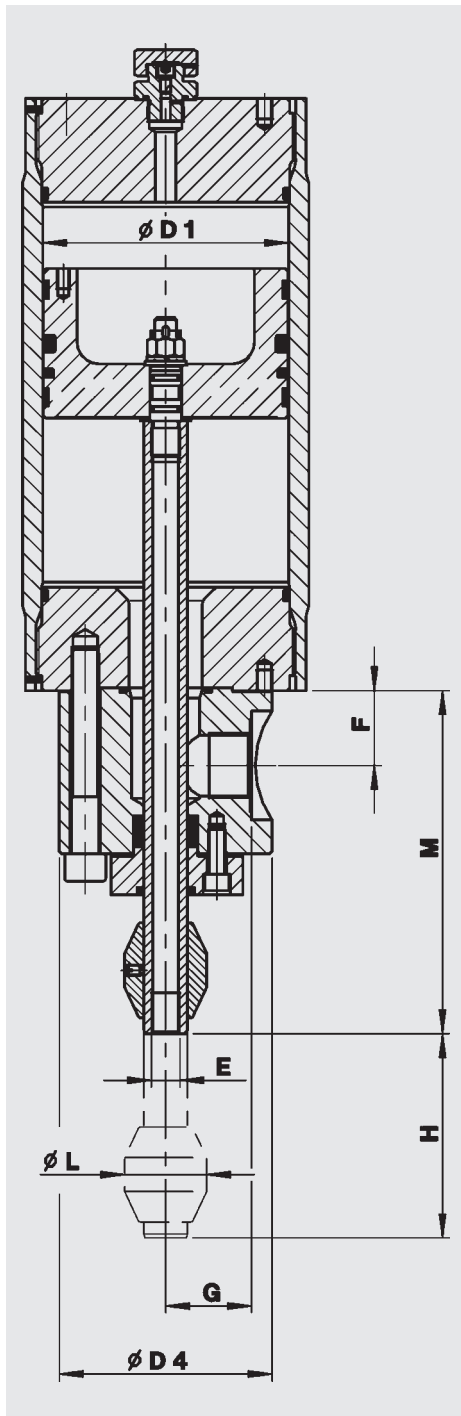

Nominal ²⁾ volume	Series	Country code U								Add- itional Weight
		Ø D1	M	Ø D4	H (stroke)	F	G	E	Ø L	
[litres]		[mm]	[mm]	[mm]	[mm]	[mm]	[mm]	[ISO228]	[mm]	[kg]
0.2										
0.5	SK350	60 ¹⁾								
1										
0.5	SK350	80 ¹⁾								
1										
2										
2.5	SK350	100	214	100	316	35	42	G 1/8	38	7
5					636					7.5
7.5					956					8
2	SK350	125			165					7
5					405					7.5
15					1220					8
6	SK350	150			340					14
20					1130					20
40					2265					30
10	SK210	180	275	156	788	55	63			13
	SK350									
20	SK210									
50	SK350									
20	SK350	200			635					16
40					1275					20
100					3185					35
50	SK210	250	300	200	1017	55	89	G 1/2	60	31
	SK350									
80	SK210									
	SK350									
120	SK210	SK350	2447	35						
	SK350									
120	SK350	310			1598					39
150					1988					40
200					2653					42
130	SK210	355	300	245	1311	63	110			89
	SK350									
180	SK210									
	SK350									
250	SK210	SK350	2526	106						
	SK350									
200	SK350	490								
400										
600										

- 1) Protruding piston rod is not possible for these piston sizes.
2) Volume details are examples, others on request.

Standard fluid connection:
(others on request)

- G 1 for piston diameters 100, 125
G 1½ for piston diameters 150, 180, 200
G 2 for piston diameters 250
NW 50 for piston diameters 310, 355

3.3. PISTON ACCUMULATOR WITH ELECTRICAL LIMIT SWITCH

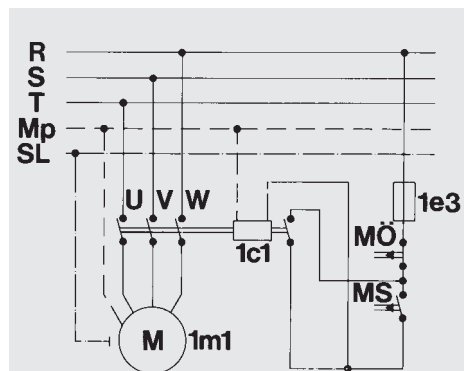
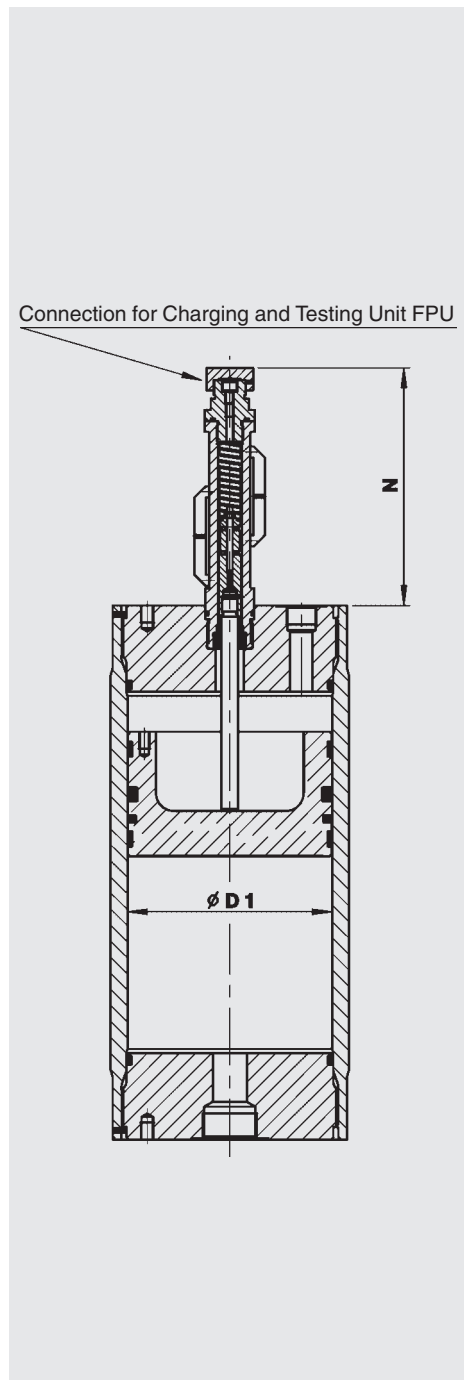

- 1m1 = motor
- 1c1 = motor protection
- 1e3 = control cut-out
- Mö = solenoid switch - normally closed contact
- Ms = solenoid switch - normally open contact

Nominal ²⁾ volume [litres]	Series	Country code U			Additional Weight				
		Ø D1 [mm]	Gas side connection ³⁾ [ISO228]	N [mm]	A [kg]	B [kg]	C [kg]		
0.2	SK350	60 ¹⁾							
0.5									
1									
0.5	SK350	80 ¹⁾							
1									
2									
2.5	SK350	100	G 3/4 lateral				2.55	4.85	7.15
5									
7.5									
2	SK350	125							
5									
15									
6	SK350	150	G 3/4						
20									
40									
10	SK210	180	G 1				2.60	4.90	7.20
	SK350								
20	SK210								
	SK350	200	G 1				2.65	4.95	7.25
50	SK210								
	SK350								
20	SK350	200	G 1	209	439	679			
40									
100									
50	SK210	250	G 1 1/4				2.80	5.10	7.40
	SK350								
80	SK210								
	SK350	310	G 1 1/4				2.90	5.20	7.50
120	SK210								
	SK350								
120	SK350	310	G 1 1/4						
150									
200									
130	SK210	355	G 1 1/2				2.80	5.10	7.40
	SK350								
180	SK210								
	SK350	490	G 2				3.00	5.30	7.60
250	SK210								
	SK350								
200	SK350	490	G 2						
400									
600									

- 1) Electrical limit switch is not possible for these piston sizes.
- 2) Volume details are examples, others on request.
- 3) Standard connection for back-up type, others on request.

Standard fluid connection:
(others on request)

- G 1 for piston diameters 100, 125
- G 1½ for piston diameters 150, 180, 200
- G 2 for piston diameters 250
- NW 50 for piston diameters 310, 355

Note:

When ordering spare parts for the piston accumulator with electrical limit switch, the supplementary seal must be ordered in addition to the seal kit (Point 4).

Supplementary seal (Table 7)

Piston diameter (mm)	Type	NBR Stock no.	Viton Stock no.
All diameters	1	00601078	00601109
	2		
	3		

4. SPARE PARTS

4.1. PISTON ACCUMULATOR

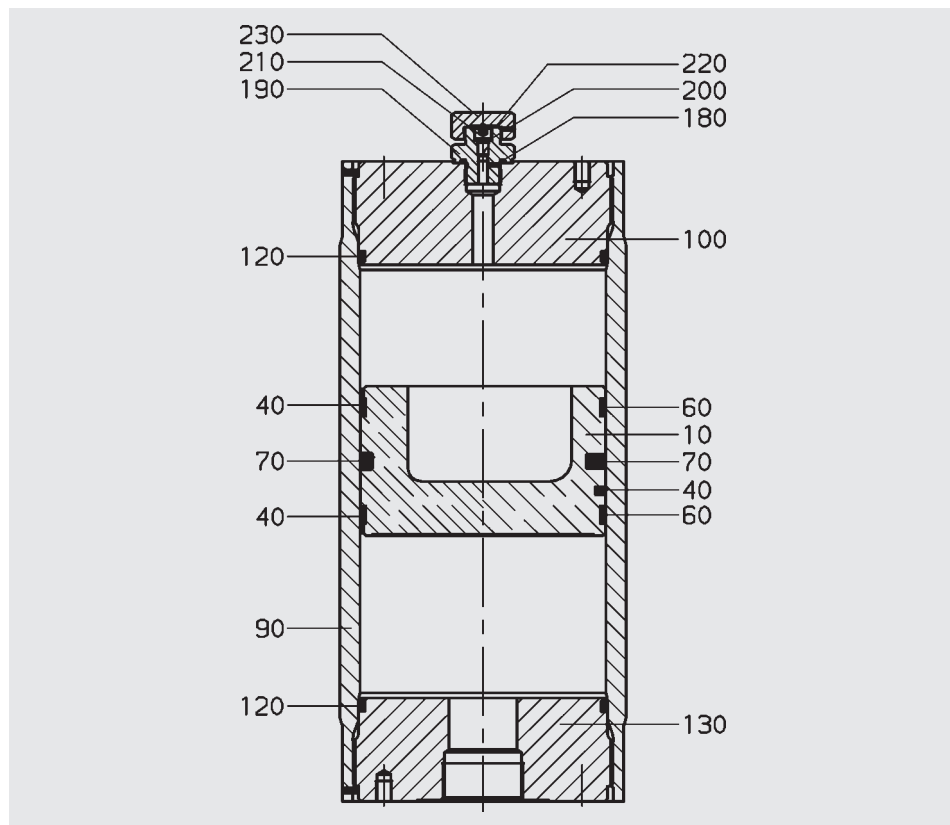

Complete piston (Table 8)

Piston diam. [mm]	Type	NBR Stock no.	FPM Stock no.	PU Stock no.
60	1	-	-	-
	2	-	-	-
	3	-	-	03009372
80	1	-	-	-
	2	00352225	02101559	-
	3	03016255	-	02119931
100	1	03128922	03128926	-
	2	00356847	00359860	-
	3	03016163	-	02115547
125	1	-	-	-
	2	03016232	03016253	-
	3	03016254	-	03016150
150	1	-	-	-
	2	03016228	03016229	-
	3	03016230	-	03016231
180	1	03128923	03128927	-
	2	00350244	00353976	-
	3	03016169	-	02121568
200	1	-	-	-
	2	03016214	03016215	-
	3	03016216	-	03016218
250	1	03128924	03128938	-
	2	00353980	00353981	-
	3	03009544	-	03016171
310	1	-	-	-
	2	03016195	03016197	-
	3	-	-	-
355	1	03128925	03128939	-
	2	00356382	00354079	-
	3	-	-	-
490	1	-	-	-
	2	03128989	03128990	-
	3	-	-	-

Complete seal kit (Table 9)

Piston diam. [mm]	Type	NBR Stock no.	FPM Stock no.	PU Stock no.
60	1	-	-	-
	2	-	-	-
	3	-	-	03016210
80	1	-	-	-
	2	02123890	02123891	-
	3	03016247	-	03013230
100	1	03128940	03128944	-
	2	00363268	00363269	-
	3	03010398	-	02123414
125	1	-	-	-
	2	03016212	03016234	-
	3	03016233	-	02128104
150	1	-	-	-
	2	03016235	03016237	-
	3	03016236	-	03016239
180	1	03128941	03128945	-
	2	00363270	00363271	-
	3	03010399	-	02123415
200	1	-	-	-
	2	03016240	03016242	-
	3	03016241	-	03016243
250	1	03128942	03128946	-
	2	00363266	00363267	-
	3	03010401	-	03016213
310	1	-	-	-
	2	03016200	03016201	-
	3	-	-	-
355	1	03128943	03128947	-
	2	00363272	00363273	-
	3	-	-	-
490	1	-	-	-
	2	03104100	03128991	-
	3	-	-	-

4.1.1 Piston type 1

Description	Qty.	Item
Complete piston consisting of:		
Piston	1	10
Seal ring	2	40
Centre seal	1	70
Complete seal kit consisting of:		
Seal ring	2	40
Centre seal	1	70
O-ring	2	120
O-ring	1	180
Seal ring	1	200
O-ring	1	220

4.1.2 Piston type 2

Description	Qty.	Item
Complete piston consisting of:		
Piston	1	10
Seal ring	1	40
Guide ring	2	60
Centre seal	1	70
Complete seal kit consisting of:		
Seal ring	1	40
Guide ring	2	60
Centre seal	1	70
O-ring	2	120
O-ring	1	180
Seal ring	1	200
O-ring	1	220

4.1.3 Piston type 3

Description	Qty.	Item
Complete piston consisting of:		
Piston	1	10
Seal ring	1	40
Guide ring	1	60
Complete seal kit consisting of:		
Seal ring	1	40
Guide ring	1	60
O-ring	2	120
O-ring	1	180
Seal ring	1	200
O-ring	1	220

Pressure resistant parts cannot be supplied as spares.

4.2. ASSEMBLY RECOMMENDATION

Before assembling or dismantling an accumulator or accumulator system, the system must always be depressurised.

The gas and fluid side must be depressurised and the gas valve unscrewed or opened before the accumulator is dismantled. Before the end caps are removed, ensure that the piston is moving freely. This may be achieved by using a rod. Only authorised personnel should repair piston accumulators with locked pistons.

Piston accumulators with internal diameters up to 250 mm are fitted with a securing pin. This pin is to prevent the end cap being removed incorrectly. It must be taken out before removing the end cap.

There may be a risk of injury due to stray components.

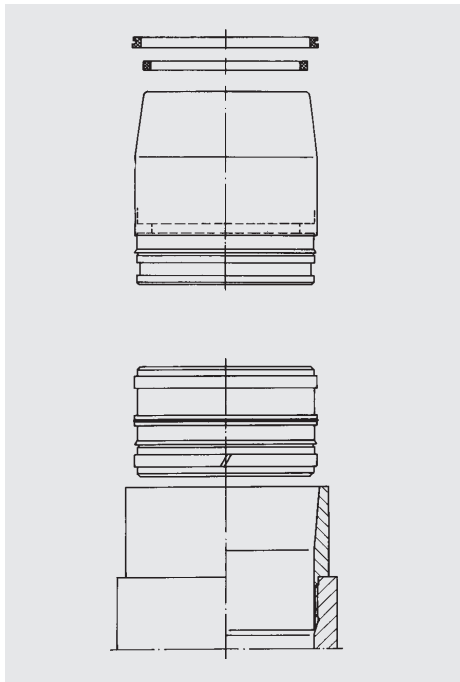

Assembly sleeves for piston accumulators (Table 11)

Piston diam.	To fit the seals	
	Type 1+2	Type 3
60	00297430	02107565
80	00244991	02104701
100	00352198	03016277
125	00370734	03016278
150	02124157	03016279
180	00350148	03016280
200	03016276	03016281
250	00290035	03016282
310	02127304	–
355	00354147	–
490	3114220	–

Piston diam.	To mount the piston
60	02120188
80	00359614
100	00290056 (M105x2) 02117672 (M110x3)
125	02128223
150	02124161
180	00290049 (M186x3) 02122356 (M190x4)
200	03016284
250	00290046
310	02127305
355	00290985
490	03114219

5. NOTE

The information in this brochure relates to the operating conditions and applications described.

For applications or operating conditions not described, please contact the relevant technical department.

Subject to technical modifications.