

HYDAC

INTERNATIONAL

SAE Threaded Flange Ball Valves KHBG-F3/6 / KHMG-F3/6

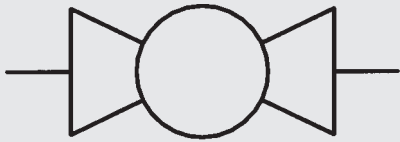

up to 400 bar
up to DN 50

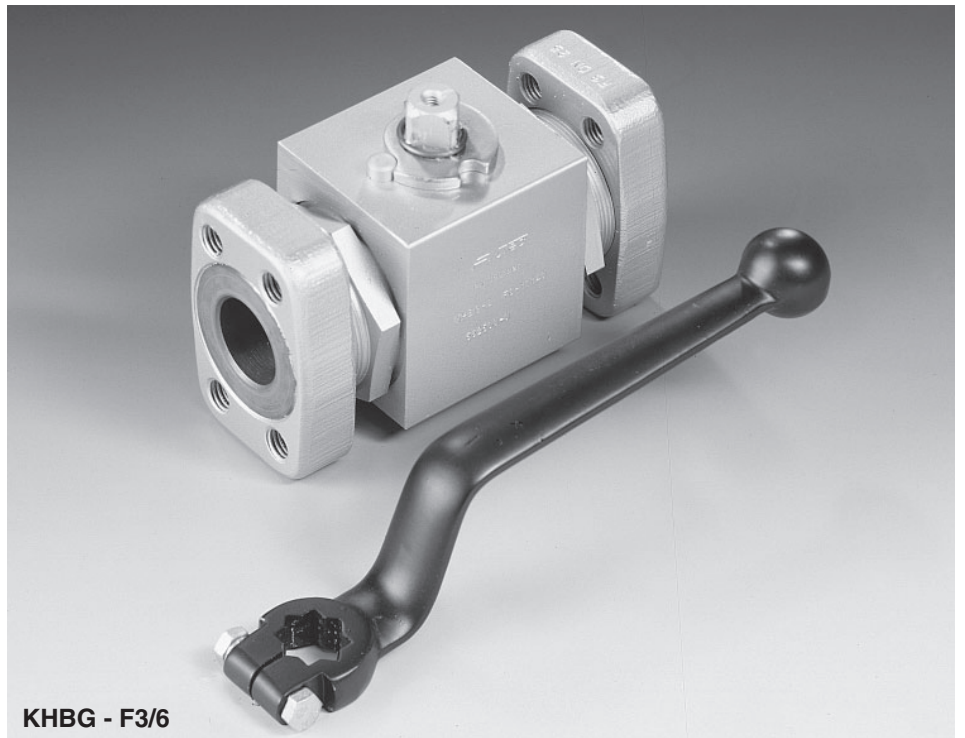

KHBG - F3/6

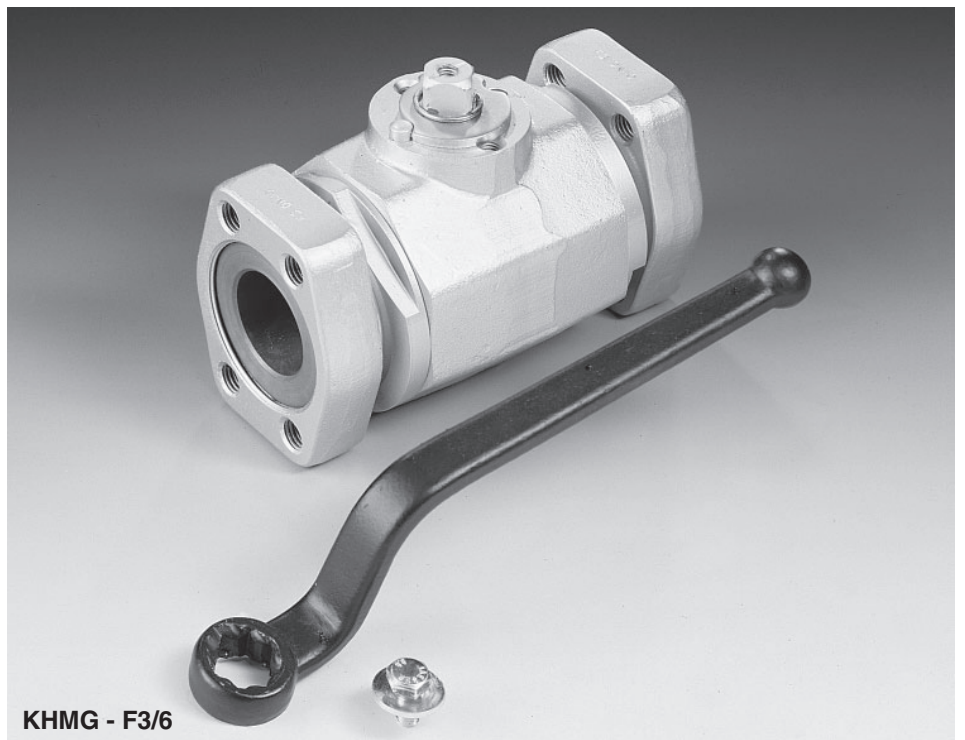

KHMG - F3/6

1. DESCRIPTION

1.1. GENERAL

According to DIN-ISO 1219, 2-way SAE threaded flange ball valves are units which serve to shut off the flow of an operating medium in both directions.

There are two different models:

- Block type (KHBG) - DN 16 - 25
- Sleeve type (KHMG) - DN 32 - 50

These ball valves have the following advantages:

- Visual indication of the switching position by means of a slot on the control spindle
- Switching limited by means of stop pin and limit disc
- No glands, therefore no manual re-adjustment of seals required
- Sealing principle with floating ball, sealing on both sides
- Full flow passage for unrestricted flow of medium
- SAE threaded flange can be rotated
- Easy operation
- Surface phosphate-plated

For flanged ball valves, see brochure no.: E 5.502../..

For SAE flanged ball valves see brochure no.: E 5.513../..

For SAE fixed flange ball valves see brochure no.: E 5.521../..

On request we can supply other models to cover nearly all applications e.g. aggressive or gaseous liquids, as well as quality test certificates to DIN 55350, Part 18.

1.2. FUNCTION

Turning the control spindle moves the ball from the open to the closed switching position.

The system pressure pushes the ball against the non-pressurised side of the sealing cup and shuts off the flow leakage-free.

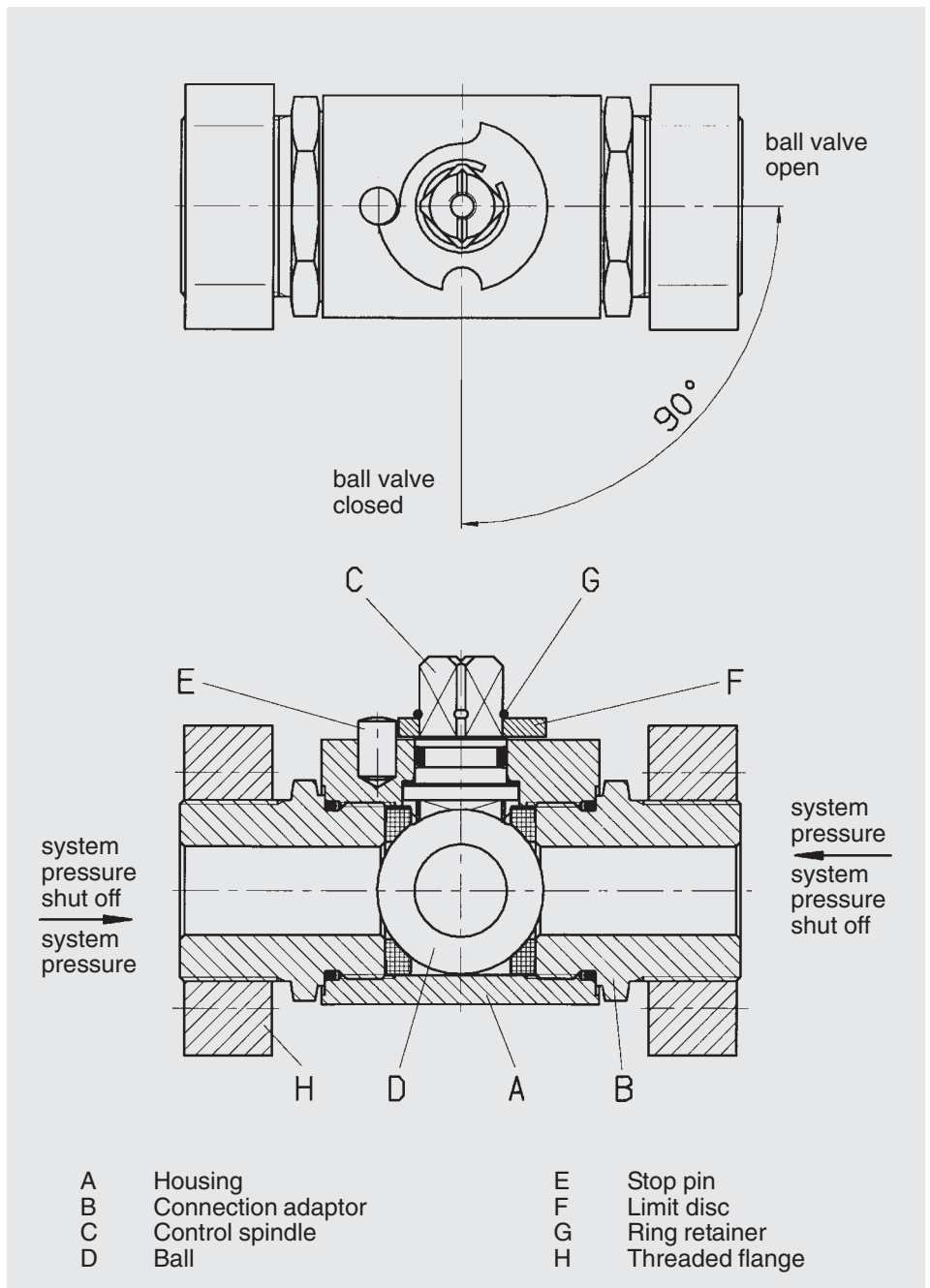

1.3. APPLICATION

SAE threaded flange ball valves KHBG/KHMG – F3 / F6 are used to shut off flow in hydraulic circuits.

Areas of application are for example:

- Pipeline construction
- Machine tools
- System engineering
- Off-shore sector

1.4. NOTES

Ball valves are not designed to be used as flow control valves; therefore they should always be either fully open or fully closed to avoid damaging the sealing cups.

To ensure correct functioning, pressure and temperature specifications must be observed.

The permitted operating pressure of the ball valve and the flange connection must be observed.

The handles are supplied loose with the ball valves.

2. TECHNICAL SPECIFICATIONS

2.1. GENERAL

2.1.1 Designation and symbol

Block type ball valve - threaded flange KHBG – F3/F6

Sleeve type ball valve - threaded flange KHMG – F3/F6

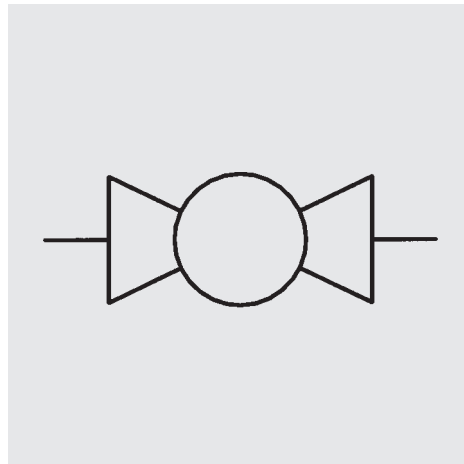

2.1.2 Model code (also order example)

KHBG - 20 - F3 - 11141 - 02 - X

Designation

KHBG = block type ball valve – threaded flange
DN 16-25

KHMG = sleeve type ball valve – threaded flange
DN 32-50

Nominal width

SAE flange type

F3
F6

Materials

Housing, connection adaptors
and control spindle (steel)

Ball (steel)

Sealing cups (POM)

Control spindle seal and
connection seal, Viton (FKM)

SAE threaded flanges (steel)

Material code

1

1

1

4

1

Handle

02 = aluminium clamped handle, cranked (AK)

06 = steel bolt-on handle, cranked (SK)

Series

(Determined by manufacturer)

Please quote stock number when ordering (see table 2.1.3).
Delivery for non-standard valves is longer and the price is higher.

2.1.3 Standard models

Type of connection SAE - F3/F6	SAE size	Nominal bore / type	Nominal bore DN	Nominal pressure PN (bar)	Order no. = Stock no.	Weight (kg)
SAE-F3 Threaded flange connection ISO 6162, Table 1 (SAE J 518 c)	1/2 "	KHBG - 16 - F3 - 11141-02X	16	350	3031351	1.1
	3/4 "	KHBG - 20 - F3 - 11141-02X	20	350	3031352	1.9
	1 "	KHBG - 25 - F3 - 11141-02X	25	350	3031353	2.4
	1 1/4 "	KHMG - 32 - F3 - 11141-06X	32	275	562512	3.8
	1 1/2 "	KHMG - 40 - F3 - 11141-06X	40	210	562513	4.5
	2 "	KHMG - 50 - F3 - 11141-06X	50	210	562514	6.5
SAE-F6 Threaded flange connection ISO 6162, Table 2 (SAE J 518 c)	1/2 "	KHBG - 16 - F6 - 11141-02X	16	400	3031354	1.2
	3/4 "	KHBG - 20 - F6 - 11141-02X	20	350	3031355	2.0
	1 "	KHBG - 25 - F6 - 11141-02X	25	350	3031356	2.6
	1 1/4 "	KHMG - 32 - F6 - 11141-06X	32	350	562518	4.0
	1 1/2 "	KHMG - 40 - F6 - 11141-06X	40	350	562519	4.7
	2 "	KHMG - 50 - F6 - 11141-06X	50	350	562520	7.2

- 2.1.4 **Type of construction**
Shut off device is a ball.
- 2.1.5 **Type of connection**
SAE threaded flange to ISO 6162, Table 1 and 2 (SAE J 518 c)
- 2.1.6 **Mounting position**
Optional
- 2.1.7 **Weight**
See table 2.1.3
- 2.1.8 **Flow direction**
Optional
- 2.1.9 **Ambient temperature**
-10 °C to + 80 °C
- 2.1.10 **Materials**
Housing, connection adaptors, flanges and control spindle in steel - surface phosphate-plated
Ball in steel, hard chromed
Ball seals in high quality synthetic material (POM)
Soft seals in Viton (FKM)
Cranked clamped handle SW 12 - 14 in aluminium, red anodised
Cranked bolt-on handle SW 17 in steel, zinc-plated
- 2.2. HYDRAULIC DETAILS
- 2.2.1 **Nominal pressure**
PN 210 bar to PN 400 bar (see table 2.1.3)
- 2.2.2 **Operating fluids**
Mineral oil to DIN 51524 Part 1 and Part 2 (other media on request)
- 2.2.3 **Temperature of operating fluid**
- 10 °C to + 80 °C

3. DIMENSIONS

3.1. HANDLE

Cranked clamped handle

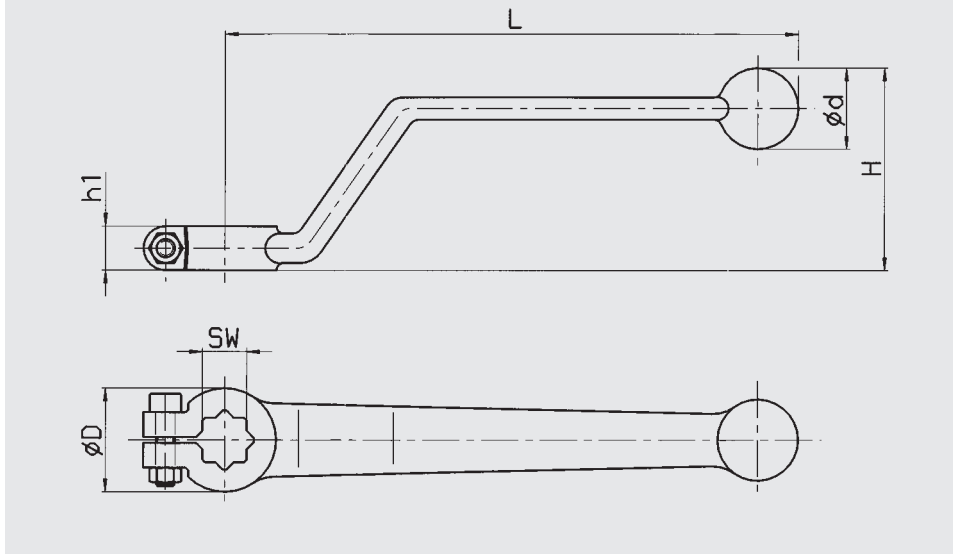

L	H	ØD	Ød	h1	SW	Ball valve nominal bore	Type	Order no. = Stock no.
163	52	28	22	12	12	16	02 (AK)	270381
183	54	32	24	12	14	20 - 25	02 (AK)	270382

Cranked bolt-on handle

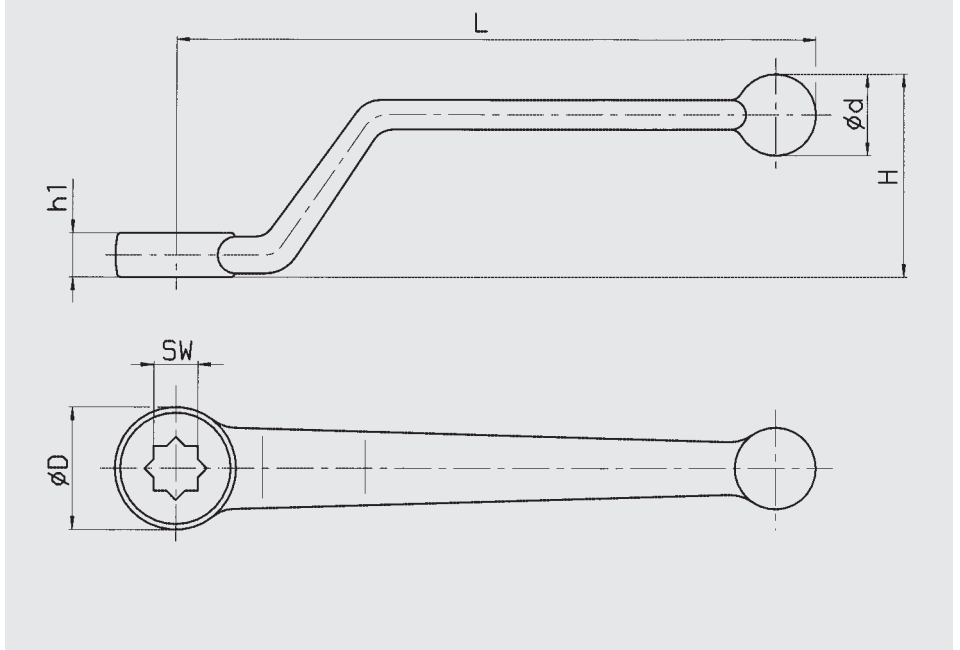

L	H	ØD	Ød	h1	SW	Ball valve nominal bore	Type	Order no. = Stock no.	Fixing bolt Order no. = Stock no.
228	80	34	20	14	17	32 - 50	06 (SK)	273662	638600

3.1.1 Notes on assembly

The clamped handle is pushed onto the square end of the ball valve spindle and clamped to the square by means of a screw through the end of the handle.

Clamped handle

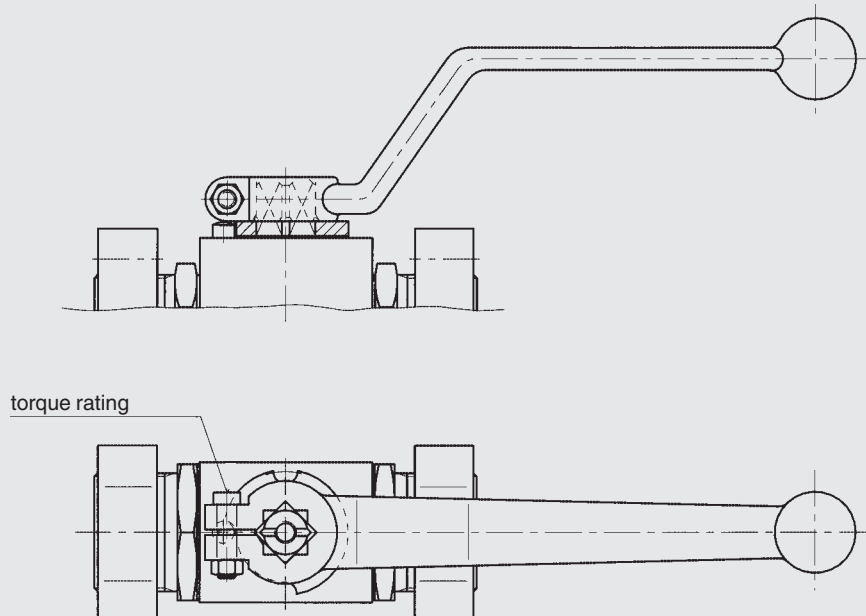

	SW 12 M 5 x 20	SW 14 M 6 x 30
Torque rating	3 Nm	5 Nm

The bolt-on handle is screwed to the ball valve control spindle by means of a fixing bolt from above.

Bolt-on handle

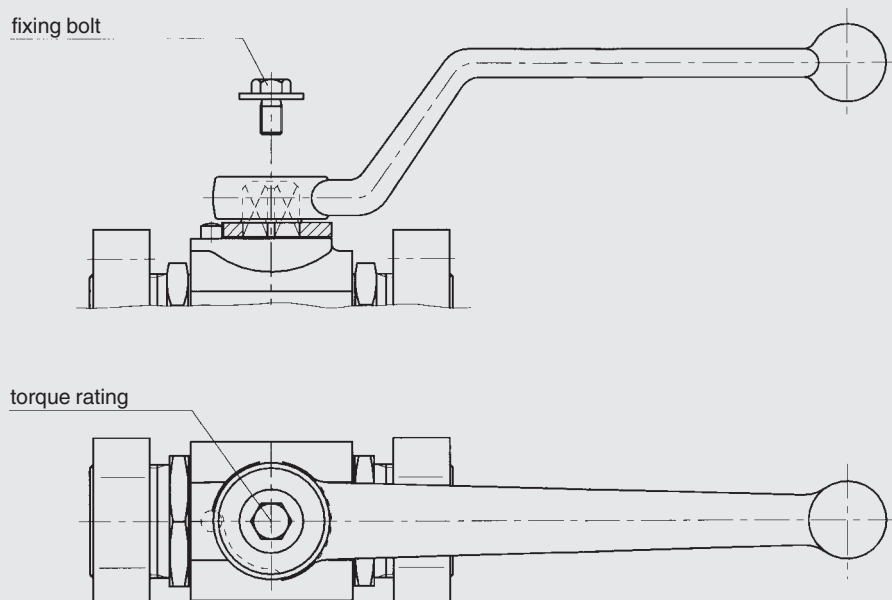

	SW 17
Fixing bolt	M 8 x 16
Torque rating	5 Nm

Both types of handle can be displaced by 45°.

3.2. SAE THREADED FLANGE BALL VALVES
KHBG

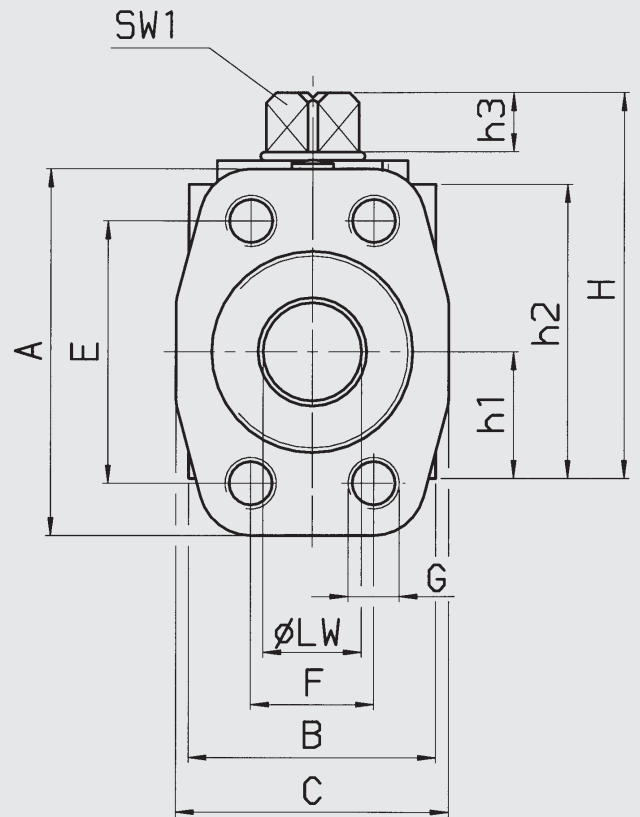
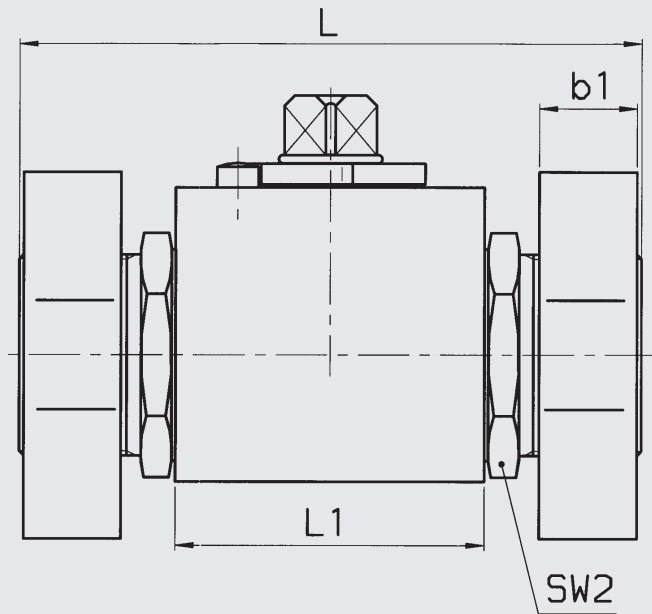

KHMG

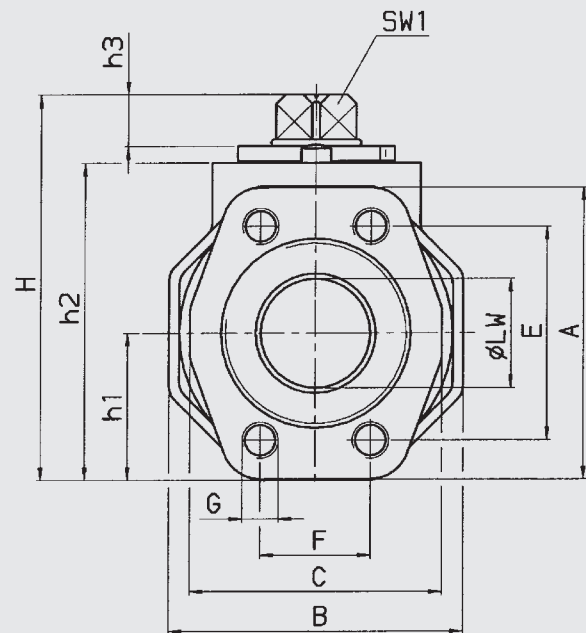
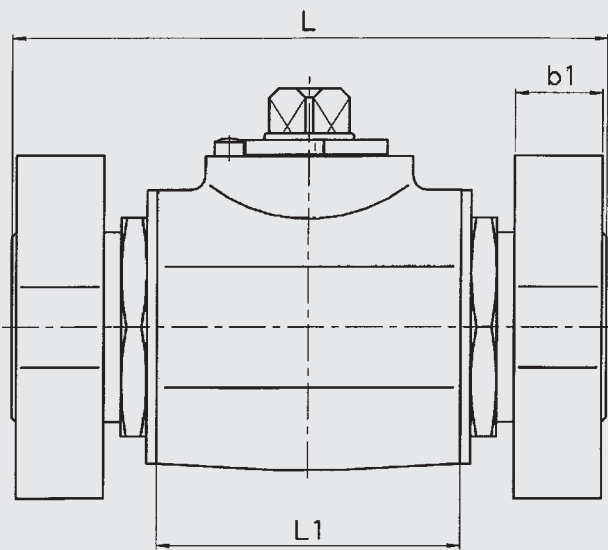

KHBG-F3 / KHMG-F3

Type	SAE size	DN	LW	L	L1	H	h1	h2	h3	B	SW 1	SW 2
KHBG-16-F3	1/2 "	16	13	104	47.0	62.0	19.0	45.0	11	38	12	32
KHBG-20-F3	3/4 "	20	19	121	60.0	75.0	24.5	57.0	11	48	14	41
KHBG-25-F3	1 "	25	25	133	65.0	82.0	28.5	64.0	11	57	14	50
KHMG-32-F3	1 1/4 "	32	30	163	83.4	103.0	37.5	85.0	12	75	17	60
KHMG-40-F3	1 1/2 "	40	38	168	91.0	114.0	42.5	96.0	12	85	17	70
KHMG-50-F3	2 "	50	48	186	100.0	131.5	52.5	112.5	12	105	17	80

Flange F3

Type	b1	A	C	E	F	G
KHBG-16-F3	16	57	47	38.1	17.5	M 8
KHBG-20-F3	18	66	49	47.6	22.3	M10
KHBG-25-F3	19	71	53	52.4	26.2	M10
KHMG-32-F3	21	80	69	58.7	30.2	M10
KHMG-40-F3	24	95	77	69.9	35.7	M12
KHMG-50-F3	24	103	89	77.8	42.9	M12

KHBG-F6 / KHMG-F6

Type	SAE size	DN	LW	L	L1	H	h1	h2	h3	B	SW 1	SW 2
KHBG-16-F6	1/2 "	16	13	104	47.0	62.0	19.0	45.0	11	38	12	32
KHBG-20-F6	3/4 "	20	19	121	60.0	75.0	24.5	57.0	11	48	14	41
KHBG-25-F6	1 "	25	25	133	65.0	82.0	28.5	64.0	11	57	14	50
KHMG-32-F6	1 1/4 "	32	30	163	83.4	103.0	37.5	85.0	12	75	17	60
KHMG-40-F6	1 1/2 "	40	38	168	91.0	114.0	42.5	96.0	12	85	17	70
KHMG-50-F6	2 "	50	48	186	100.0	131.5	52.5	112.5	12	105	17	80

Flange F6

Type	b1	A	C	E	F	G
KHB-16-F6	16	57	47	40.5	18.2	M 8
KHB-20-F6	19	71	53	50.8	23.8	M10
KHB-25-F6	21	80	66	57.2	27.8	M12
KHM-32-F6	24	94	77	66.6	31.8	M14
KHM-40-F6	24	103	89	79.3	36.5	M16
KHM-50-F6	30	135	123	96.8	44.5	M20

4. SPARE PARTS

(Seal kit)

KHBG, DN 16 - 25

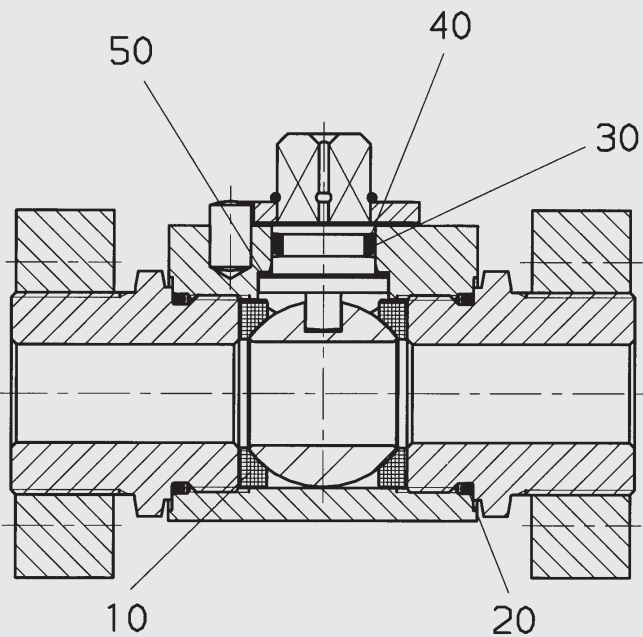

KHMG, DN 32 - 50

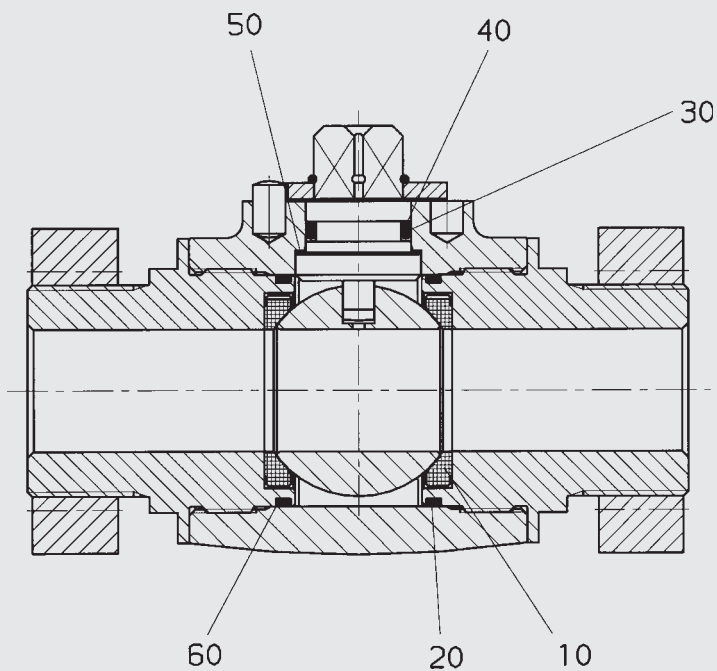

Seal kit	Order no. = Stock no.
DN 16	703003
DN 20	703016
DN 25	700978
DN 32	703025
DN 40	703015
DN 50	701293

The parts indicated by numbers on the drawings are all included in the seal kit.

5. NOTE

The information in this brochure relates to the operating conditions and applications described.

For applications or operating conditions not described, please contact the relevant technical department.

Subject to technical modifications.