

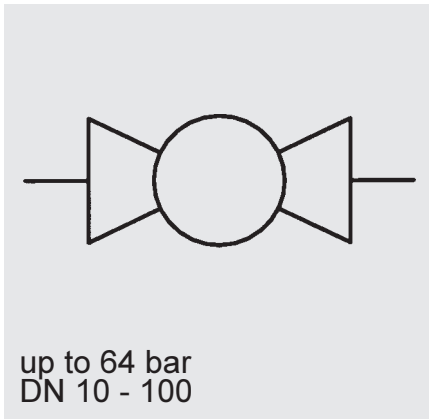

## Weld-Type Low Pressure Ball Valves KHM3S



**Model code**  
(also order example)

**KHM3S 20 1333 16 X**

### Designation

KHM3S = Three-part weld-type low pressure ball valve

### Nominal width

### Material code

1	3	3	3
Steel	Stainless steel	Teflon (PTFE)	Teflon (PTFE)
Housing Butt weld - C 22 (ASTM A 105) Spindle - 1.4301 (AISI 304)	ball	ball seal	seal - PTFE soft seal - Viton (FKM)
3	3	3	3
Stainless steel	Stainless steel	Teflon (PTFE)	Teflon (PTFE)
Housing Butt weld - 1.4401 (AISI 316) Spindle	ball	ball seal	seal - PTFE soft seal - Viton (FKM)

### Handle

- 16 = Steel handle, cranked
- 18 = Stainless steel handle, cranked (DN 10 - 50)

### Modification number

(Determined by manufacturer)

## Dimensions

KHM3S

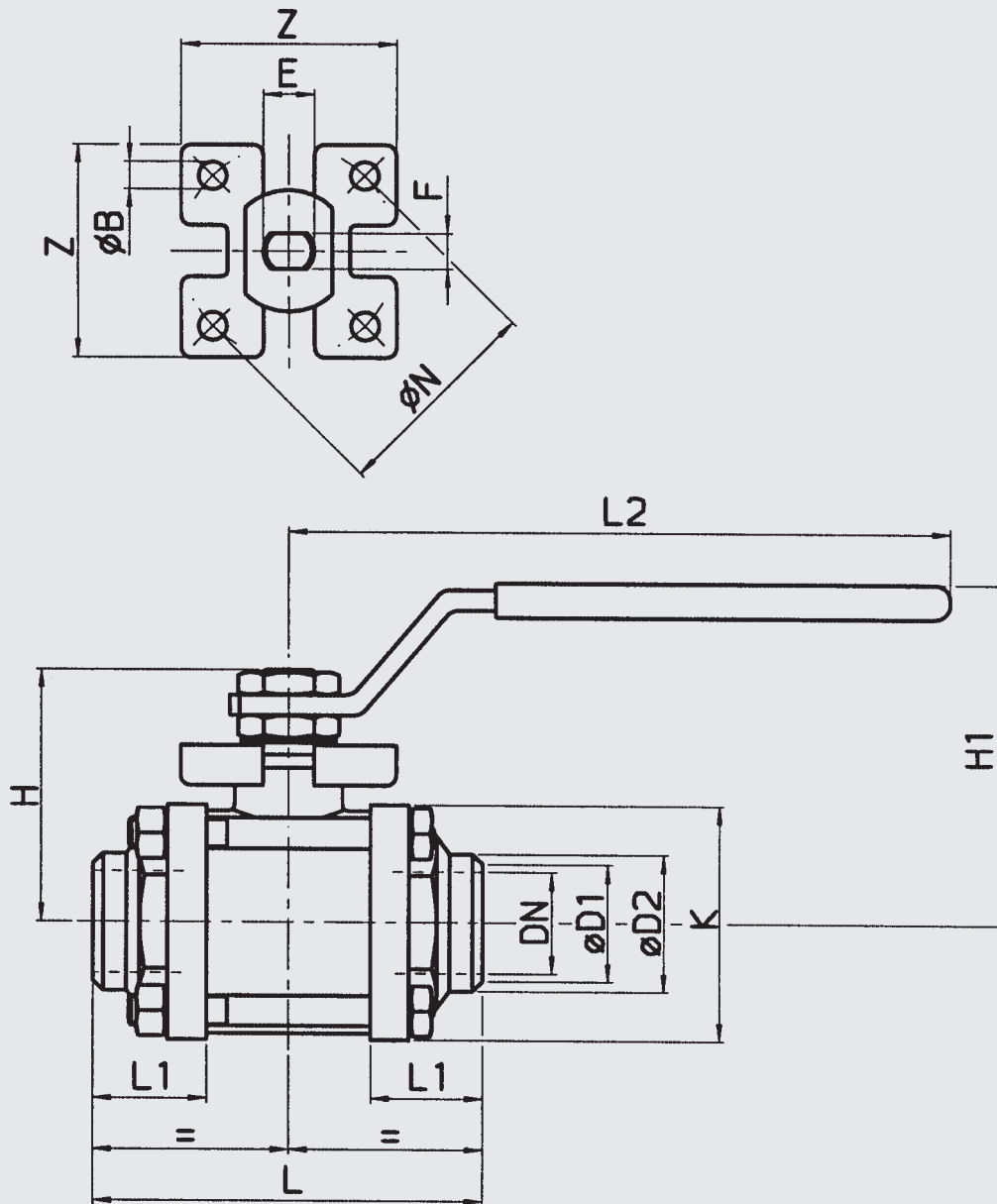

Type / Steel 1333	DN	D1	D2	H	H1	L	L1	L2
KHM3S - 10	10	13.6	17.2	47	64	65	20.5	131.5
KHM3S - 15	15	18	21.4	47	64	65	20.5	131.5
KHM3S - 20	20	23	27	51.5	68	76	22.5	131.5
KHM3S - 25	25	28	34	60	78	92	27	174.5
KHM3S - 32	32	35	42	64.5	83	106.5	30	174.5
KHM3S - 40	40	43	49	77.5	99.5	116	31	250.5
KHM3S - 50	50	54	60	85	107	136	36	250.5
KHM3S - 65	65	69	77	103	126.5	153.5	38.5	321.5
KHM3S - 80	80	84	90	114	137.5	180	43	321.5
KHM3S - 100	100	104	116	137	156.5	217	50	381.5

Type / Steel 1333	K	Z	B	N	F	E	Weight (kg)	PN (bar)
KHM3S - 10	38	–	–	–	7	10	0.45	64
KHM3S - 15	38	–	–	–	7	10	0.40	64
KHM3S - 20	46.5	–	–	–	7	10	0.60	40
KHM3S - 25	58	–	–	–	8	12	1.10	40
KHM3S - 32	66.5	–	–	–	8	12	1.53	25
KHM3S - 40	76	–	–	–	10	16	2.10	25
KHM3S - 50	90	50	–	–	10	16	3.20	25
KHM3S - 65	134	65	M 8	70 F07	14	20	8.30	16
KHM3S - 80	161	65	M 8	70 F07	14	20	13.40	16
KHM3S -100	190	92	M10	102 F10	18	24	22.20	16

Type / Stainless steel 3333	DN	D1	D2	H	H1	L	L1	L2
KHM3S - 10	10	13.6	17.2	35	50	55	17	110.5
KHM3S - 15	15	18	21.4	47	64	65	20.5	131.5
KHM3S - 20	20	23	27	51.5	68	76	22.5	131.5
KHM3S - 25	25	28	34	60	78	92	27	174.5
KHM3S - 32	32	35	42	64.5	83	106.5	30	174.5
KHM3S - 40	40	43	49	78	100	116	31	250.5
KHM3S - 50	50	54	60	85	107	136	36	250.5
KHM3S - 65	65	69	77	103	126.5	153.5	38.5	321.5
KHM3S - 80	80	84	90	114	137.5	180	43	321.5
KHM3S -100	100	104	116	137	156.5	217	50	381.5

Type / Stainless steel 3333	K	Z	B	N	F	E	Weight (kg)	PN (bar)
KHM3S - 10	33	–	–	–	5	8	0.28	64
KHM3S - 15	38	36	6	36 F03	7	10	0.40	64
KHM3S - 20	46.5	42	5.5	42 F04	7	10	0.60	40
KHM3S - 25	58	42	5.5	42 F04	8	12	1.10	40
KHM3S - 32	66.5	42	5.5	42 F04	8	12	1.50	25
KHM3S - 40	76	50	6.5	50 F05	10	16	2.10	25
KHM3S - 50	90	50	6.5	50 F05	10	16	3.20	25
KHM3S - 65	134	65	M 8	70 F07	14	20	8.10	16
KHM3S - 80	161	65	M 8	70 F07	14	20	12.80	16
KHM3S -100	190	92	M10	102 F10	18	24	21.50	16

## Technical data

Connection:	butt weld
Mounting position:	optional
Ambient temperature:	-20 °C to + 160 °C
Nominal pressure:	up to PN 64 bar
Operating media:	mineral oil to DIN 51524 Part 1 + 2, gaseous media, compressed air, water other media on request
Temp. of operating medium:	-20 °C to + 160 °C

**Spare parts:** Sealing kit (on request)

**Accessories:** all ball valves available with following options: Actuator  
Limit switch  
Locking device

## Note

The information in this brochure relates to the operating conditions and applications described.  
For applications or operating conditions not described, please contact the relevant technical department.  
Subject to technical modifications.