

HYDAC

INTERNATIONAL

3-Way Manifold Mounted Ball Valves KHP3K

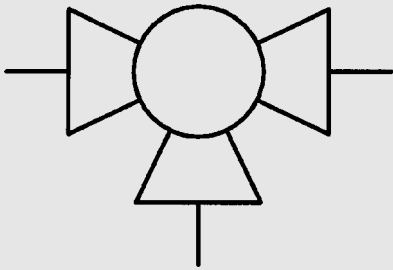

up to 500 bar
up to DN 32

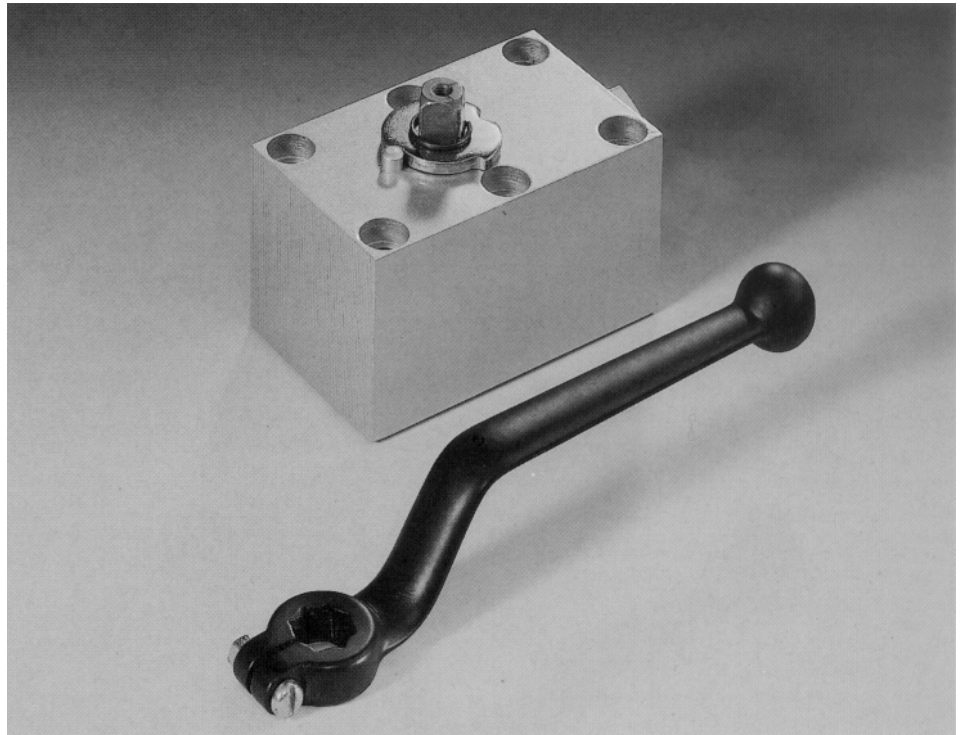

1. DESCRIPTION

1.1. GENERAL

According to DIN 2429, FLUTEC 3/2-way manifold mounted ball valves are units for shutting off and diverting the flow of an operating medium.

These ball valves have the following advantages:

- Visual indication of the switching position by means of a slot on the control spindle
 - Switching limiting by means of stop pin and stop disc
 - No glands, therefore no manual re-adjustment of seals required
 - Floating ball sealing principle, sealing at the outlet side
 - Full flow passage to ensure unrestricted flow of the medium
 - Easy operation
 - Surface phosphate-plated
- FLUTEC 3/2-way manifold mounted ball valves are available in stainless steel.

FLUTEC handle, for full details see brochure no. E 5.515../..

On request we can supply other models to cover nearly all applications, e.g. for aggressive or gaseous media. Quality test certificates to DIN 55350, Part 18, can also be supplied if required.

1.2. FUNCTION

By turning the control spindle the flow is diverted, according to the ball bore, and the opposite side is shut off leakage-free.

The system pressure pushes the ball against the non-pressurised side of the closed-off sealing cup. The ball shuts off the flow from port 1 to port 2 or 3 leakage-free.

When the direction of flow is from 2 or 3 to 1, some leakage can be expected, depending on the pressure. During change-over all three ports are linked (negative switching overlap).

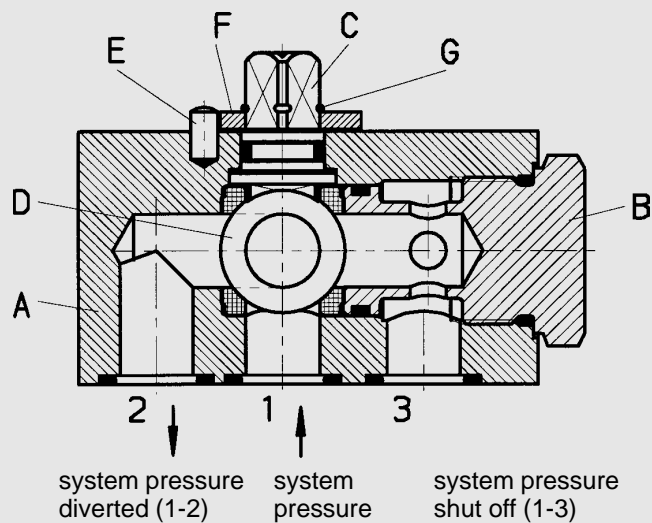
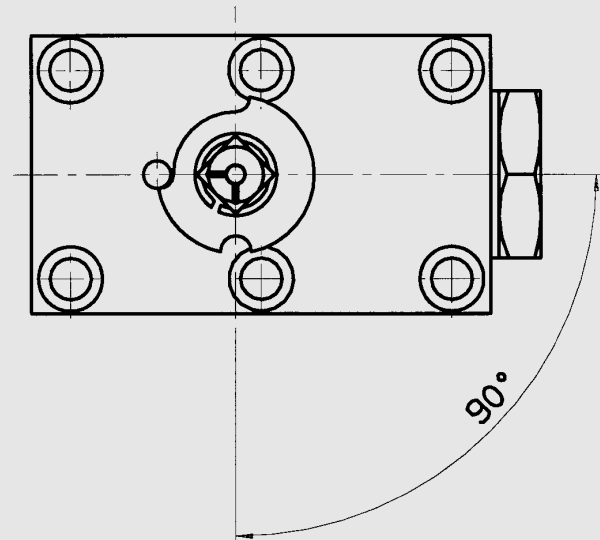

- | | |
|---------------------|-------------------|
| A = Housing | E = Stop pin |
| B = Locking screw | F = Limit disc |
| C = Control spindle | G = Ring retainer |
| D = Ball | |

1.3. APPLICATION

FLUTEC 3/2-way manifold mounted ball valves are used to divert flow in hydraulic circuits.

Areas of application are, for example:

- Machine tools
- System engineering
- Off-shore sector
- Valve and/or control block combinations

1.4. NOTES

Ball valves are not designed to be used as flow control valves; therefore they should always be either fully open or fully closed in order to avoid damaging the sealing cups.

To ensure correct functioning, pressure and temperature specifications must be observed.

O-rings for the connection side are supplied with the ball valve.

The handles are supplied loose with the ball valves.

2. TECHNICAL SPECIFICATIONS

2.1. GENERAL

2.1.1 Designation and symbol

3-way manifold mounted ball valve
KHP3K

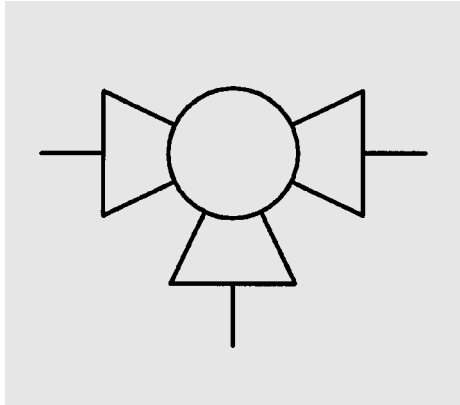

2.1.2 Model code (also order example)

KHP3K - 10 - L - 1114 - 04 X

Designation _____
KHP3K = 3-way manifold mounted ball valve

Nominal bore _____

Ball bore _____

Materials

Housing, locking screw and control spindle (steel)

Ball (steel)

Sealing cups (POM)

Control spindle seal and adaptor seal
Viton (FKM)

Material code

1 _____

1 _____

1 _____

4 _____

Handle

14 = zinc die-cast bolt-on handle, cranked (ZK), fitted DN 06

04 = zinc die-cast bolt-on handle, cranked (ZK) DN 10

02 = aluminium clamped handle, cranked (AK) DN 16 - 25

06 = steel bolt-on handle, cranked (SK) DN 32

09 = without handle (DN 10 - 32)

Series

(determined by manufacturer)

Please quote stock no. when ordering (see table 2.1.5)

Delivery for non-standard models is longer and the price is higher.

2.1.3 Standard model functions

3/2-way manifold mounted ball valve
negative switching overlap

L-bore

90° switch

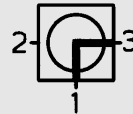
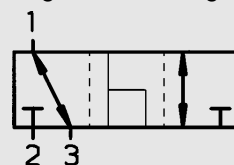

undefined switching position

2.1.4 Non-standard model functions SO 560.1

By using special sealing cup seals and balls, it is possible to cover further applications.

Using this special model any of the connection bores can be pressurised. There is no detent on the centre setting and the switch is 2 x 90°.

3/3-way manifold mounted ball valve
positive switching overlap

L-bore

180° switch

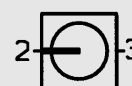
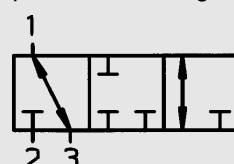

2.1.5 Standard valves

Type / Nominal bore	Nominal bore DN	Nominal pressure PN (bar)	Order no. = stock no.	Weight (kg)
KHP3K-06-L-1114-14X	06	500	554623	0.55
KHP3K-10-L-1114-04X	10	315	703879	1.10
KHP3K-16-L-1114-02X	16	315	853221	2.00
KHP3K-20-L-1114-02X	20	315	853210	3.60
KHP3K-25-L-1114-02X	25	315	853284	5.40
KHP3K-32-L-1114-06X	32	315	398469	10.20

2.1.6 Construction

The shut-off and/or diverting device is a ball.

2.1.7 Type of connection

Manifold connection for mounting onto valve or control blocks

For interfaces see page 8

2.1.8 Mounting position

Optional

2.1.9 Weight

(see table 2.1.5)

2.1.10 Flow direction

Optional

2.1.11 Ambient temperature

- 10 °C to + 80 °C

2.1.12 Materials

Housing, locking screw and control spindle in steel, surface phosphate-plated

Ball in steel, hard chromed

Ball seals in high quality synthetic material (POM)

Soft seals in Viton (FKM)

Cranked handles SW 06 and

SW 09 in zinc die-casting, zinc-plated DN 06 -10,

SW 12-14 in aluminium, red anodised DN 16 - 25 and SW 17 in steel, zinc-plated DN 32

2.2. HYDRAULIC DETAILS

2.2.1 **Nominal pressure**
 PN 315 bar to PN 500 bar
 (see table 2.1.5)

2.2.2 **Operating fluid**
 Mineral oil to DIN 51524, Part 1
 and Part 2.
 (Other media on request)

2.2.3 **Temperature of operating fluid**
 - 10 °C to + 80 °C

3. DIMENSIONS

3.1. HANDLE

Cranked clamped handle

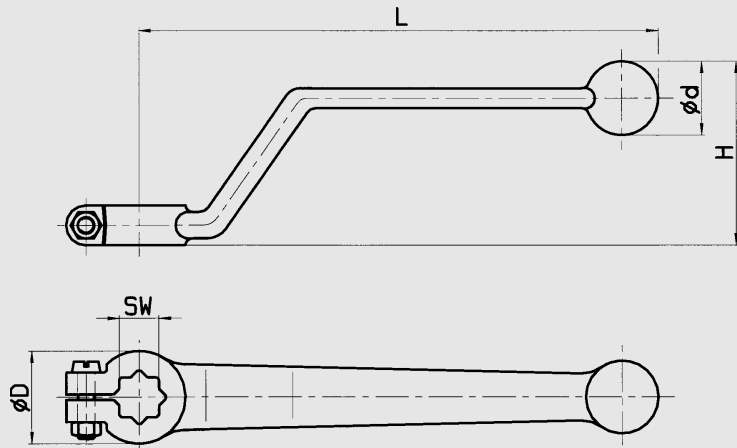

L	ØD	Ød	H	SW	Ball valve nominal bore	Type	Order no. = stock no.
156	28	22	49	12	16	02 (AK)	270381
173	32	24	52	14	20 - 25	02 (AK)	270382

Cranked bolt-on handle

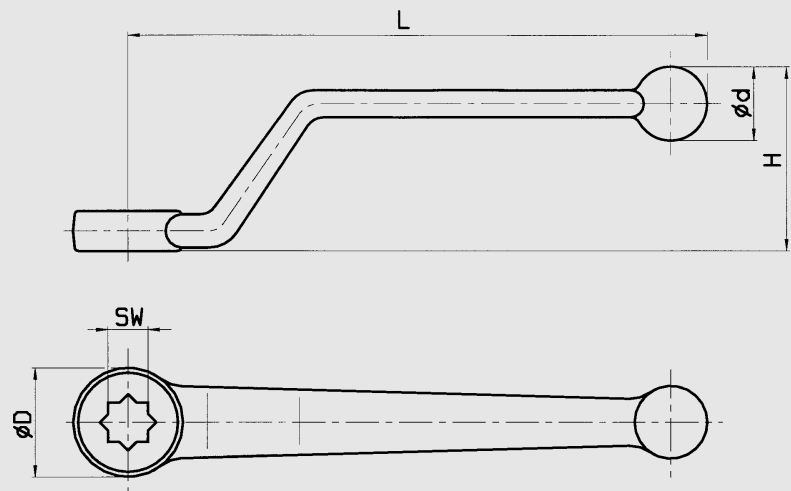

L	ØD	Ød	H	SW	Ball valve nominal bore	Type	Order no. = stock no.	Fixing bolt
60	20	10	23	06	06	14 (ZK)	389707	637051
108	22	10	23	09	10	04 (ZK)	556352	633766
213	36	25	67	17	32	06 (SK)	273662	633768

3.1.1 Notes on assembly

The cranked handle is pushed onto the square end of the ball valve spindle and clamped to the square by means of a screw through the end of the handle.

Clamped handle

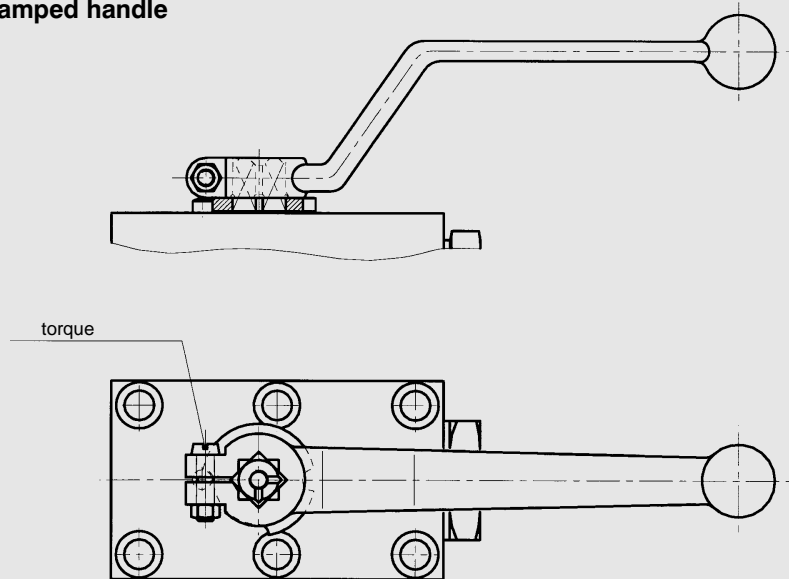

	SW 12	SW 14
Torque	3 Nm	5 Nm

The bolt-on handle is screwed onto the ball valve control spindle from above using a fixing bolt.

Bolt-on handle

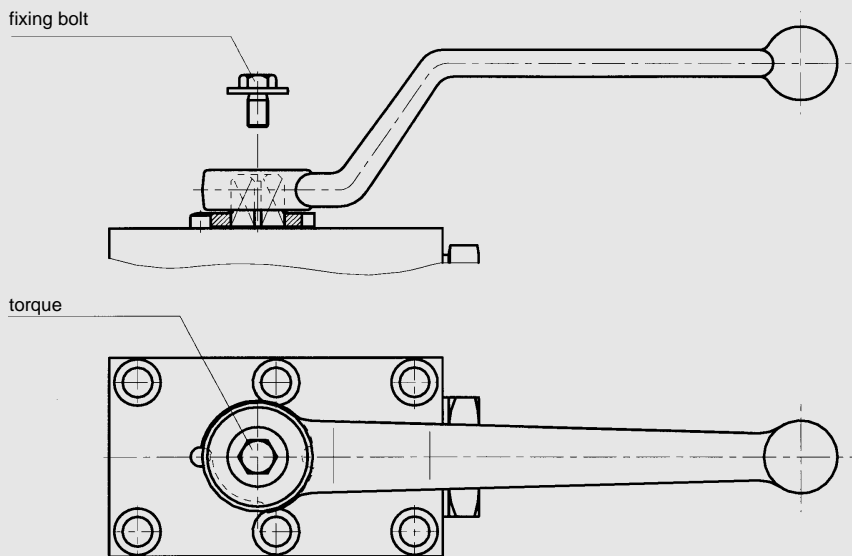

	SW 06	SW 09	SW 17
Fixing bolt	M 3 x 8	M 5 x 12	M 8 x 16
Torque	0.6 Nm	3 Nm	5 Nm

The handles can be displaced by 45°.

3.2. 3-WAY MANIFOLD MOUNTED BALL VALVE

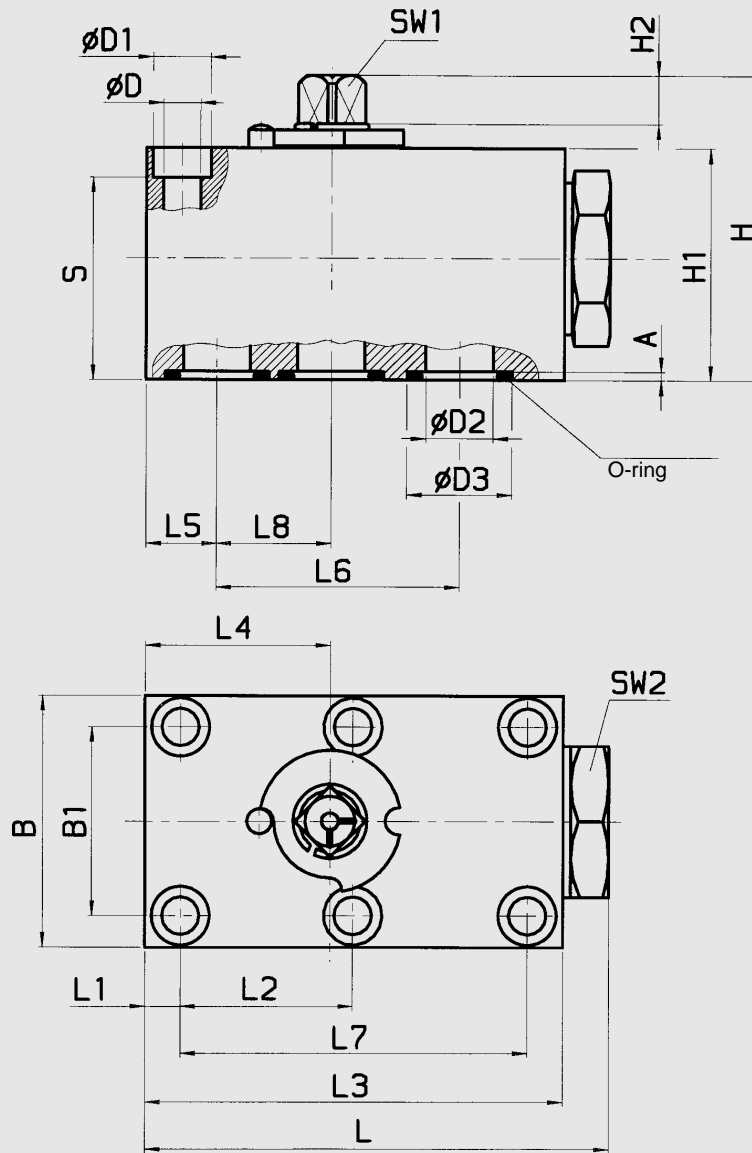

Type / Nominal bore	DN	LW	L	L1	L2	L3	L4	L5	L6	L7	L8	B	B1	SW 1
KHP3K-06	06	6.0	64	8.5	17.5	59	25.0	8.5	35	35	17.5	40	27	06
KHP3K-10	10	9.5	80	7.5	27.5	70	29.0	10.0	44	55	19.0	55	40	09
KHP3K-16	16	16.0	110	8.5	41.5	100	44.5	17.0	58	83	26.5	60	45	12
KHP3K-20	20	20.0	127	10.0	48.5	117	51.0	20.0	69	97	31.0	70	51	14
KHP3K-25	25	23.5	145	10.0	57.5	135	62.0	24.0	81	115	38.0	80	60	14
KHP3K-32	32	32.0	176	12.0	68.0	165	75.0	29.0	96	136	46.0	100	78	17

Type / Nominal bore	SW 2	H	H1	H2	D	D1	D2	D3	A	S	O-ring
KHP3K-06	22	37.5	30	7.0	6.6	11.0	6.0	11.7	1.6	23.0	8 x2
KHP3K-10	30	58.0	45	8.5	9.0	14.0	9.5	15.0	2.0	36.0	10 x2.6
KHP3K-16	36	72.5	55	11.0	9.0	14.0	16.0	25.0	2.0	46.0	20.29 x2.62
KHP3K-20	41	88.5	70	11.0	10.5	16.5	20.0	30.0	2.9	59.5	23.39 x3.53
KHP3K-25	50	97.5	80	11.0	10.5	17.0	23.5	35.0	2.9	69.0	28.17 x3.53
KHP3K-32	65	118.5	100	12.0	13.0	19.0	32.0	39.4	2.9	84.0	32.92 x3.53

Type / Nominal bore	Int. hex. screw DIN 912	Torque MA [Nm] (Approx. values for friction coefficient μ 0.14)
KHP3K-06	M 6 - 10.9	13
KHP3K-10	M 8 - 10.9	30
KHP3K-16	M 8 - 12.9	35
KHP3K-20	M10 - 12.9	60
KHP3K-25	M10 - 12.9	60
KHP3K-32	M12 - 12.9	110

3.3. INTERFACE FOR 3-WAY MANIFOLD MOUNTED BALL VALVE

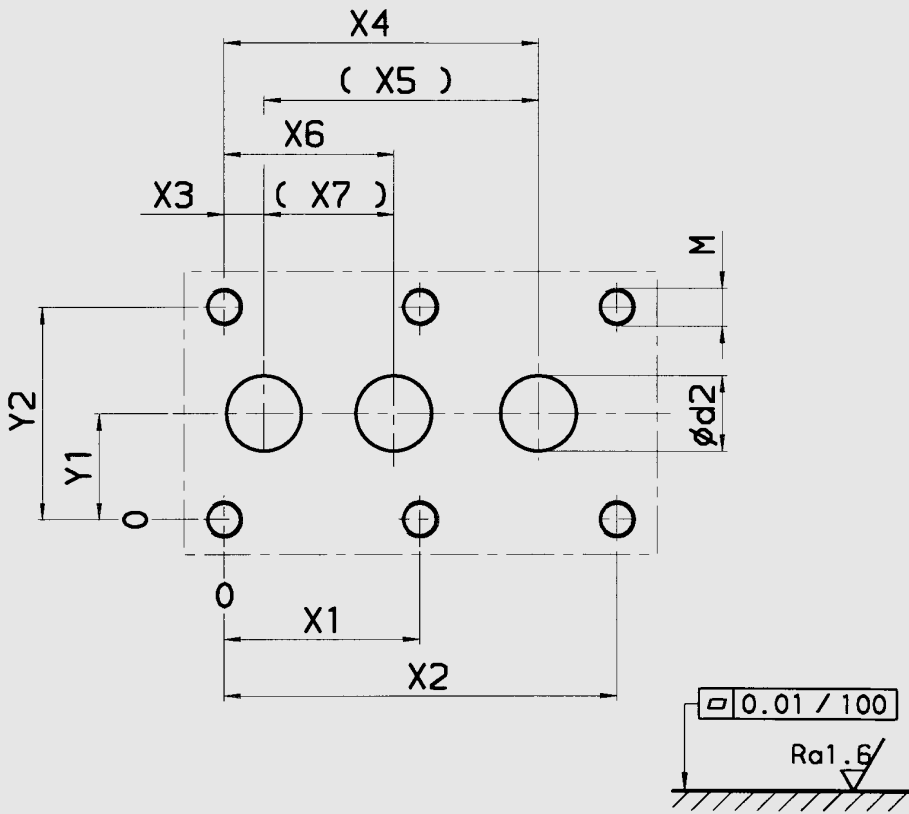

5. NOTE

All details in this brochure are subject to technical modifications.

Type / Nominal bore	Y1	Y2	X1	X2	X3	X4	X5	X6	X7	d2	M
KHP3K-06	13.5	27	17.5	35	0.0	35.0	35	17.5	17.5	6.0	M 6
KHP3K-10	20.0	40	27.5	55	2.5	46.5	44	21.5	19.0	9.5	M 8
KHP3K-16	22.5	45	41.5	83	8.5	66.5	58	35.0	26.5	16.0	M 8
KHP3K-20	25.5	51	48.5	97	10.0	79.0	69	41.0	31.0	20.0	M 10
KHP3K-25	30.0	60	57.5	115	14.0	95.0	81	52.0	38.0	23.5	M 10
KHP3K-32	39.0	78	68.0	136	17.0	113.0	96	63.0	46.0	32.0	M 12

4. SPARE PARTS (Seal kit)

Seal kit	Order no. = stock no.
DN 06	554 029
DN 10	702 113
DN 16	703 115
DN 20	703 099
DN 25	703 116
DN 32	700 977